

Standardprogramm Gasfedern
Standard programme for gas springs
Programme standard pour ressorts à gaz



...macht Technik komfortabel
...technology gives comfort
...rend la technique confortable

LIFT-O-MAT[®]

Seite
Page
Page
4– 29

Heben, senken, bewegen, verstellen.
Lifting, lowering, moving, adjusting.
Levage, descente, déplacement, réglage.

BLOC-O-LIFT[®]

Seite
Page
Page
30 – 49

Stufenlos verstellen, starr oder federnd blockieren.
Variable positioning, rigid or spring blocking.
Réglage en continu, blocage rigide ou élastique.

STAB-O-MAT[®]
STAB-O-BLOC[®]







Seite
Page
Page
50 – 69

Stufenlose Höhenverstellung von Drehstühlen
Stepless height adjustment of swivel chairs
Réglage progressif en hauteur des chaises pivotantes

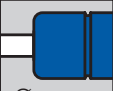
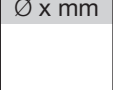
Tipps und Hinweise / Tips and Hints / Conseils et indications

70 – 72

INDEX

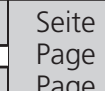
 Ø x mm	 Ø x mm	 P	 M	 P	 M	 P	 P	 P	Seite Page Page
6	15							<input type="checkbox"/>	8
6	15			<input type="checkbox"/>					9
6	15	<input type="checkbox"/>							10
6	15		<input type="checkbox"/>						11
8	19							<input type="checkbox"/>	12
8	19			<input type="checkbox"/>					13
8	19	<input type="checkbox"/>							14
8	19		<input type="checkbox"/>						15
10	22							<input type="checkbox"/>	16
10	22			<input type="checkbox"/>					17
10	22		<input type="checkbox"/>						18
14	28							<input type="checkbox"/>	20
14	28		<input type="checkbox"/>						21
20	42		<input type="checkbox"/>						22
20	42		<input type="checkbox"/>						23
8	19							<input type="checkbox"/>	24
10	22							<input type="checkbox"/>	25
14	28							<input type="checkbox"/>	26

Zubehör Seite 19
 Accessories Page 19
 Accessories Page 19

Maßangaben in mm / Änderungen vorbehalten · Dimensions in mm / We reserve the right to make modifications · Dimensions en mm / Sous réserve de changements
 08/04

LIFT-O-MAT®

Heben, senken, bewegen, verstellen.
 Lifting, lowering, moving, adjusting.
 Levage, descente, déplacement, réglage.

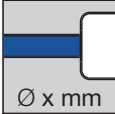
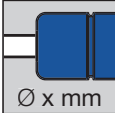
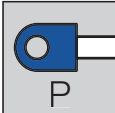
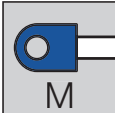
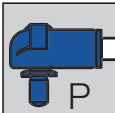
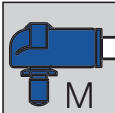
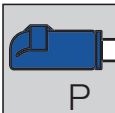
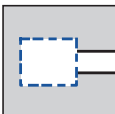
Kolbenstange Piston rod Tige de piston	 <p>Ø x mm</p>
Druckrohr Pressure tube Tube de pression	 <p>Ø x mm</p>
Auge Kunststoff Eyelet plastic Oeil plastique	 <p>P</p>
Auge Metall Eyelet metal Oeil métal	 <p>M</p>
Winkelgelenk Kunststoff Angle joint plastic Cage à rotule plastique avec rotule	 <p>P</p>
Winkelgelenk Metall Angle joint metal Cage à rotule métal avec rotule	 <p>M</p>
Winkelgelenk Kunststoff Angle joint plastic Cage à rotule plastique avec rotule	 <p>P</p>
Anschluß variabel Endfitting variable Fixation variable	
Zubehör Accessories Accessories	

Maßangaben in mm / Änderungen vorbehalten · Dimensions in mm / We reserve the right to make modifications · Dimensions en mm / Sous réserve de changements
 08/04

Notizen / Notes / Notes

A large grid area for taking notes, consisting of many small squares. The grid is approximately 30 columns wide and 50 rows high, providing a structured space for writing or drawing.

Technische Informationen
 Technical information
 Information technique

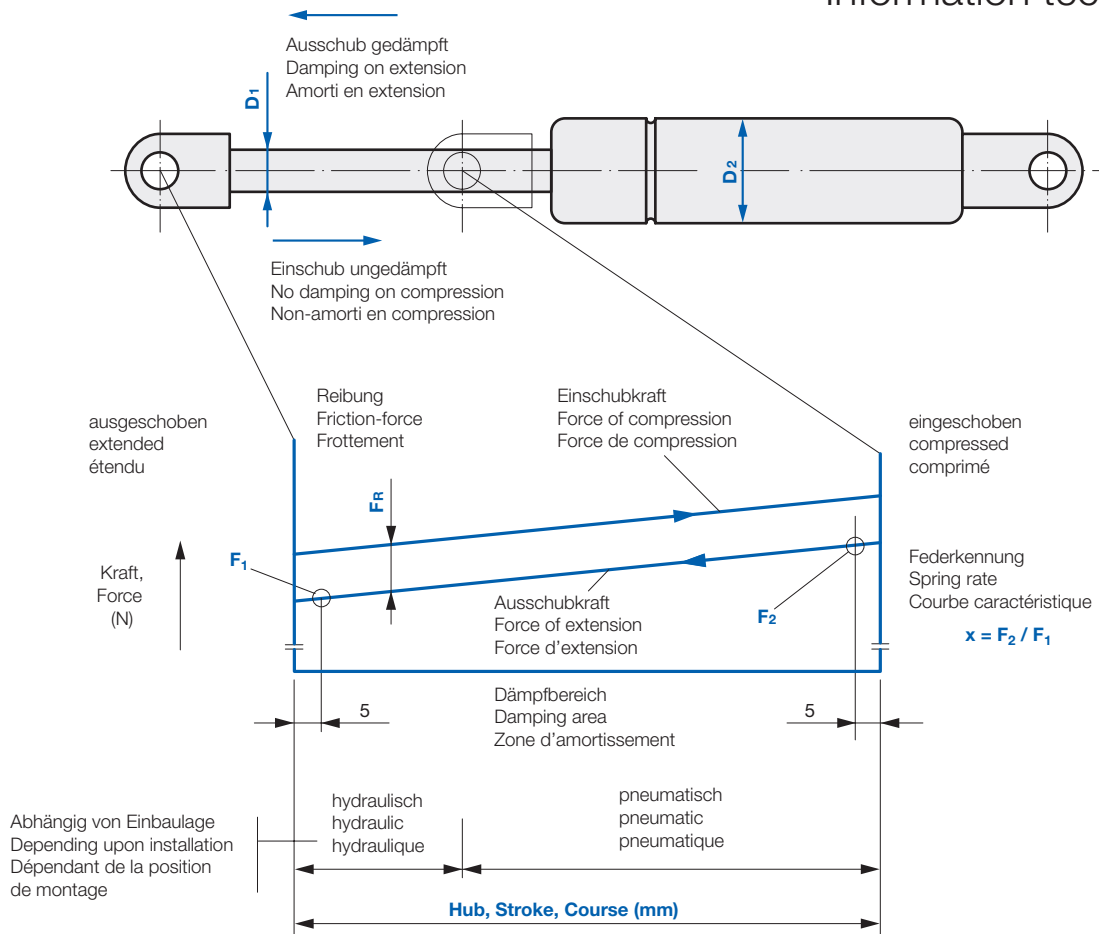

Einbaulage vorzugsweise mit Kolbenstange nach unten, hierdurch Wirksamkeit der hydraulischen Dämpfung.
 Installation: Preferably with piston rod down thus permitting effect of hydraulic cushioning.
 De préférence tige vers le bas pour obtention de l'amortissement de fin de course.

D1 (mm)	D2 (mm)	Ausschubkraft Force of extension Force d'extension F1 (N)		max. Hub Stroke Course (mm)	X (≈)	FR max. (N)	Bemerkungen Notes Nota
		min.	max.				
6	15	50	400*	150	1,30	50	* siehe Typenprogramm see standard program voir programme standard
8	19	100	800	250	1,35	60	
10	22	150	1150*	400	1,40	80	
14	28	500	2100	500	1,50	80	
20	42	2400	5200	500	1,45	150	

Einbauvorschrift
 Installation instruction
 Instruction de montage
STAB-Spec. 1000 5593

Statische Messung der Kräfte
 Statically measured forces
 Forces mesurées statiquement
STAB-Spec. 1000 9033

Entsorgungsvorschrift
 Disposal instruction
 Instruction de neutralisation
STAB-Spec. 1000 9375
www.stabilus.com/recycling

Maßangaben in mm / Änderungen vorbehalten · Dimensions in mm / We reserve the right to make modifications · Dimensions en mm / Sous réserve de changements
 08/04

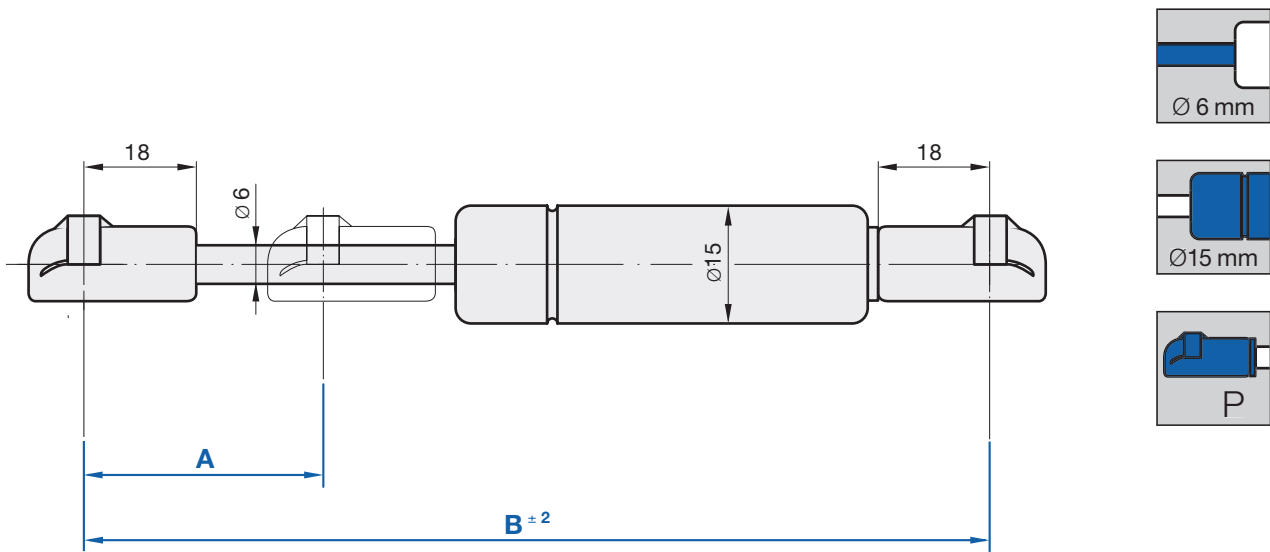

Passend für Kugelzapfen nach DIN 71803 Ø 10
 Suitable for ball studs according to DIN 71803 Ø 10
 Approprié aux rotules mâles selon DIN 71803 Ø 10

A Hub Stroke Course	B Ausgesch. Länge Extended length Longueur sortie	F ₁ - [N]	Bestell-Nr. Ref.-No. Réf.-No.
20	115,5	50	4727PB
		100	4728PX
		150	4729PS
		200	4731PZ
		250	4732PU
		300	4733PP
		350	4734PK
		400	4735PF
40	155,5	50	2606NW
		100	2607NR
		150	2608NM
		200	2609NH
		250	2611NO
		300	2612NJ
		350	2613NE
		400	2615NV
60	195,5	50	6444IK
		100	6488IU
		150	6489IP
		200	6491IW
		250	6492IR
		300	6493IM
		350	6494IH
		400	6495IC
80	235,5	50	6449IM
		100	6501IP
		150	6502IK
		200	6503IF
		250	6504IA
		300	6505IW
		350	6506IR
		400	6507IM

A Hub Stroke Course	B Ausgesch. Länge Extended length Longueur sortie	F ₁ - [N]	Bestell-Nr. Ref.-No. Réf.-No.
100	275,5	50	6458IL
		100	6508IH
		150	6509IC
		200	6511IJ
		250	6514IV
		300	6515IQ
		350	6516IL
		400	6517IG
120	315,5	50	6462II
		100	6519IX
		150	6521ID
		200	6522IZ
		250	6523IU
		300	6524IP
		350	6525IK
		400	6526IF
150	375,5	50	6467IK
		100	6539IL
		150	6541IS
		200	6542IN
		250	6543II
		300	6544ID
		350	6545IZ
		400	6153PC

Maßangaben in mm / Änderungen vorbehalten · Dimensions in mm / We reserve the right to make modifications · Dimensions en mm / Sous réserve de changements
 08/04

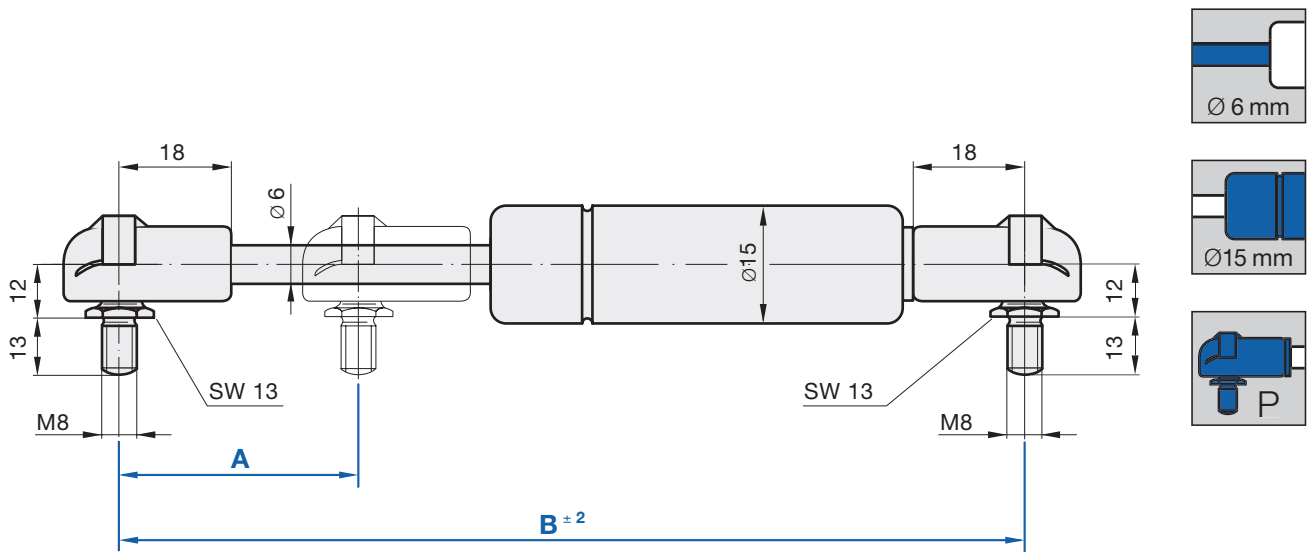

A Hub Stroke Course	B Ausgesch. Länge Extended length Longueur sortie	F ₁ - [N]	Bestell-Nr. Ref.-No. Réf.-No.
20	115,5	50	4829DF
		100	4832DH
		150	4834DY
		200	1324DI
		250	4836DO
		300	4838DE
		350	4842DB
		400	4844DS
40	155,5	50	4846DI
		100	4848DZ
		150	4851DA
		200	1338DJ
		250	4853DR
		300	4855DH
		350	4857DY
		400	4859DO
60	195,5	50	4862DQ
		100	4534DS
		150	4904DI
		200	1345DS
		250	4906DZ
		300	4908DP
		350	4911DR
		400	4913DH
80	235,5	50	4915DY
		100	4917DO
		150	4919DE
		200	1395DP
		250	4922DG
		300	4924DX
		350	4926DN
		400	4928DD

A Hub Stroke Course	B Ausgesch. Länge Extended length Longueur sortie	F ₁ - [N]	Bestell-Nr. Ref.-No. Réf.-No.
100	275,5	50	4931DF
		100	4933DW
		150	4935DM
		200	1406DD
		250	5004DJ
		300	5007DV
		350	5009DL
		400	5012DN
120	315,5	50	5025DT
		100	5027DJ
		150	5031DG
		200	1515DW
		250	5033DX
		300	5035DN
		350	5037DD
		400	5069DC
150	375,5	50	5072DE
		100	5075DQ
		150	5077DG
		200	1562DH
		250	5079DX
		300	5082DZ
		350	5084DP
		400	1205RU

Maßangaben in mm / Änderungen vorbehalten · Dimensions in mm / We reserve the right to make modifications · Dimensions en mm / Sous réserve de changements
08/04

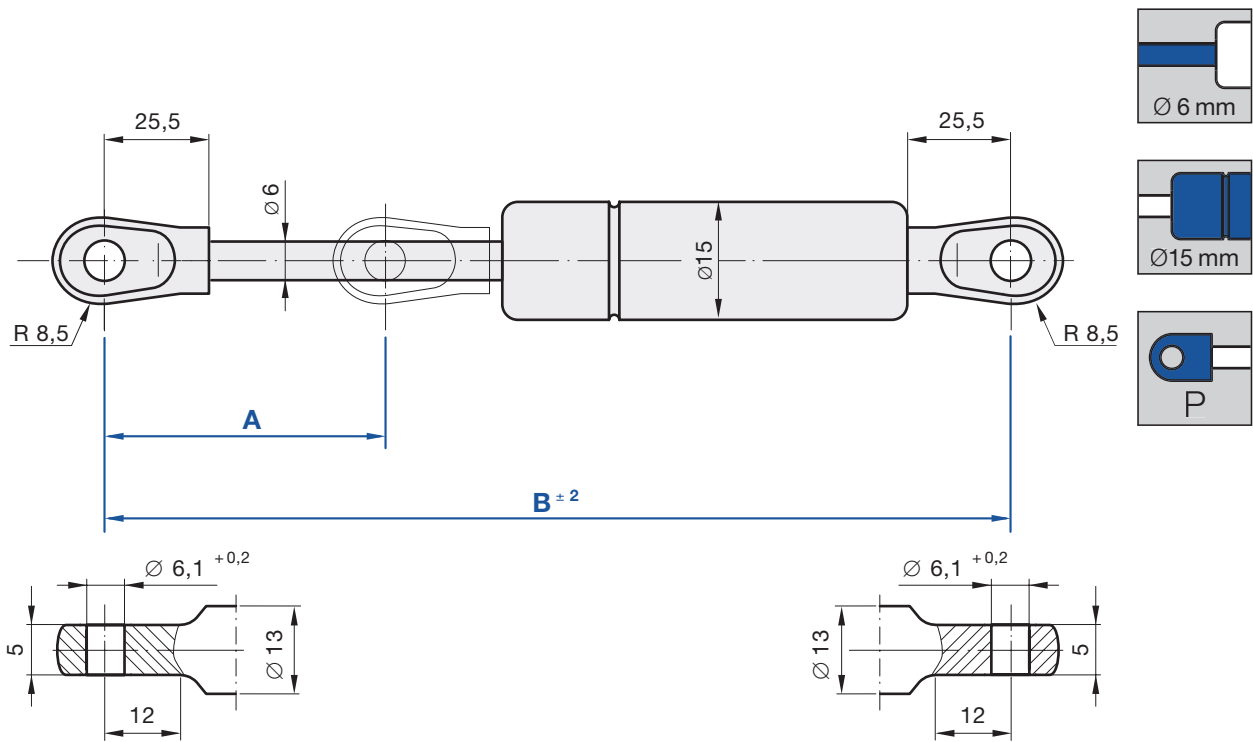

A Hub Stroke Course	B Ausgesch. Länge Extended length Longueur sortie	F ₁ - [N]	Bestell-Nr. Ref.-No. Réf.-No.
20	127,5	50	1885LI
		100	2121LY
		150	2122LT
		200	2123LO
		250	2124LJ
		300	2125LE
		350	2127LV
40	166,5	400	2128LQ
		50	1888LU
		100	2131LS
		150	2132LN
		200	2133LI
		250	2134LD
		300	2135LZ
60	206,5	350	2136LU
		400	2138LK
		50	1894LH
		100	2139LF
		150	2141LM
		200	2142LH
		250	2143LC
80	247,5	300	2144LY
		350	2145LT
		400	2146LO
		50	1901LP
		100	2148LE
		150	2151LG
		200	2152LB

A Hub Stroke Course	B Ausgesch. Länge Extended length Longueur sortie	F ₁ - [N]	Bestell-Nr. Ref.-No. Réf.-No.
80	247,5	250	2154LS
		300	2155LN
		350	2156LI
		400	2157LD
100	286,5	50	1904LA
		100	2158LZ
		150	2159LU
		200	2161LA
		250	2162LW
		300	2163LR
		350	2164LM
120	326,5	400	2165LH
		50	1908LH
		100	2208LV
		150	2209LQ
		200	2211LX
150	386,5	250	2212LS
		300	2213LN
		350	2214LI
		400	2215LD
		50	1915LQ
		100	2166LC
		150	2167LY
		200	2168LT
		250	2169LO
		300	2171LV
		350	2172LQ
		400	2352LO

Maßangaben in mm / Änderungen vorbehalten · Dimensions in mm / We reserve the right to make modifications · Dimensions en mm / Sous réserve de changements
08/04

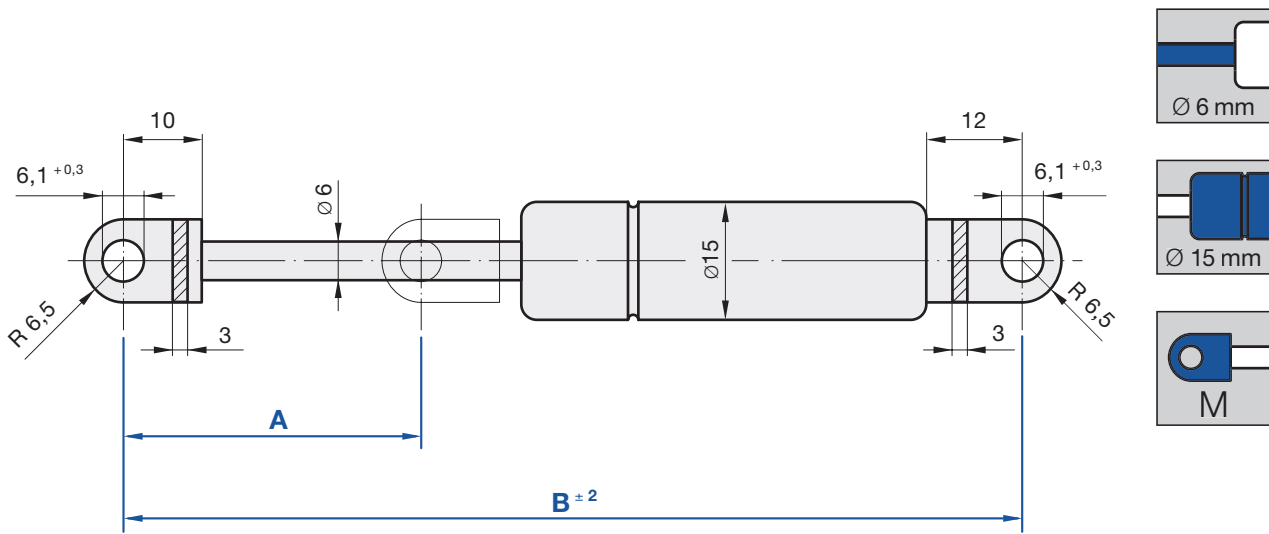

A Hub Stroke Course	B Ausgesch. Länge Extended length Longueur sortie	F ₁ - [N]	Bestell-Nr. Ref.-No. Réf.-No.
20	106,5	50	192910
		100	192929
		150	192937
		200	192945
		250	192953
		300	192961
		350	192988
		400	192996
40	145,5	50	185175
		100	191752
		150	192805
		200	192813
		250	192821
		300	082309
		350	082317
		400	094307
60	185,5	50	192848
		100	192856
		150	192864
		200	192872
		250	192880
		300	082384
		350	082392
		400	094315
80	226,5	50	082406
		100	082414
		150	082422
		200	082430
		250	082449
		300	082457
		350	082465
		400	094323

A Hub Stroke Course	B Ausgesch. Länge Extended length Longueur sortie	F ₁ - [N]	Bestell-Nr. Ref.-No. Réf.-No.
100	265,5	50	082473
		100	082481
		150	082503
		200	082511
		250	082538
		300	082546
		350	082554
		400	094331
120	305,5	50	082562
		100	082570
		150	082589
		200	082597
		250	082600
		300	082627
		350	082635
		400	094358
150	365,5	50	082643
		100	082651
		150	082678
		200	082686
		250	082694
		300	082708
		350	082716
		400	6756RS

Maßangaben in mm / Änderungen vorbehalten · Dimensions in mm / We reserve the right to make modifications · Dimensions en mm / Sous réserve de changements 08/04

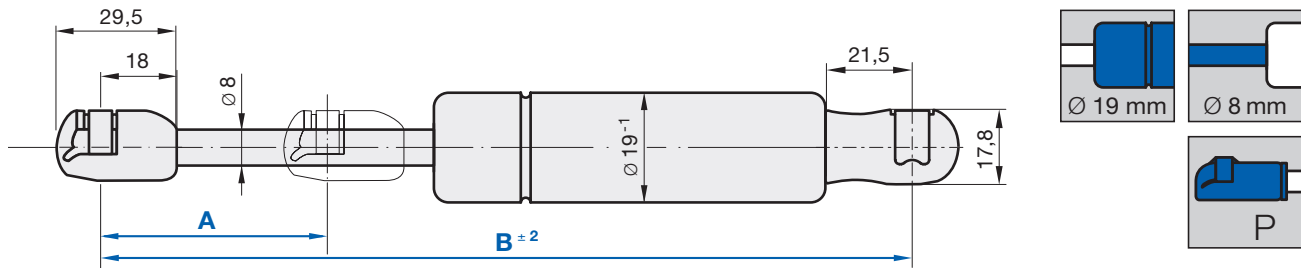

Passend für Kugelzapfen nach DIN 71803 Ø 10
 Suitable for ball studs according to DIN 71803 Ø 10
 Approprié aux rotules mâles selon DIN 71803 Ø 10

A Hub Stroke Course	B Ausgesch. Länge Extended length Longueur sortie	F ₁ - [N]	Bestell-Nr. Ref.-No. Réf.-No.		
60	205	500	2616NQ		
		600	2617NL		
		700	2618NG		
		800	2619NB		
		100	752614		
80	245	150	752622		
		200	1417EP		
		250	752630		
		300	1418EK		
		350	1419EF		
		400	752649		
		500	752657		
		600	752665		
		700	2622ND		
		800	2623NZ		
		100	285	100	752673
150	752681				
200	1421EM				
250	752703				
300	1422EH				
350	1423EC				
400	752711				
500	752738				
600	752746				
700	2624NU				
800	2625NP				
120	325			100	752754
				150	752762
		200	1424EY		
		250	752770		
		300	1425ET		
		350	1426EO		
		400	752789		
		500	752797		
		600	752800		
		700	2626NK		
		800	2627NF		
140	365	400	2628NA		
		500	2629NW		
		600	2631NC		
		700	2632NY		
		800	2633NT		
160	405	100	752819		
		150	752827		
		200	1427EJ		
		250	752835		
		300	1428EE		
		350	1431EG		
		400	752843		
		500	752851		
		600	752878		
		700	2634NO		
		800	2635NJ		

A Hub Stroke Course	B Ausgesch. Länge Extended length Longueur sortie	F ₁ - [N]	Bestell-Nr. Ref.-No. Réf.-No.
180	445	100	2636NE
		150	2638NV
		200	2639NQ
		250	2641NX
		300	2642NS
		350	2643NN
		400	2644NI
		500	2645ND
		600	2646NZ
		700	2647NU
200	485	800	2648NP
		100	752886
		150	752894
		200	1432EB
		250	752908
		300	1433EX
		350	1434ES
		400	752916
		500	752924
		600	752932
220	525	700	2649NK
		800	2651NR
		100	2652NM
		150	2653NH
		200	2654NC
		250	2655NY
		300	2656NT
		350	2657NO
		400	2658NJ
		500	2659NE
250	585	600	2661NL
		700	2662NG
		800	2663NB
		100	752940
		150	752959
		200	1435EN
		250	752967
		300	1436EI
		350	1437ED
		400	752975
260	645	500	752983
		600	752991
		700	2664NX
		800	2665NS

Maßangaben in mm / Änderungen vorbehalten · Dimensions in mm / We reserve the right to make modifications · Dimensions en mm / Sous réserve de changements 08/04

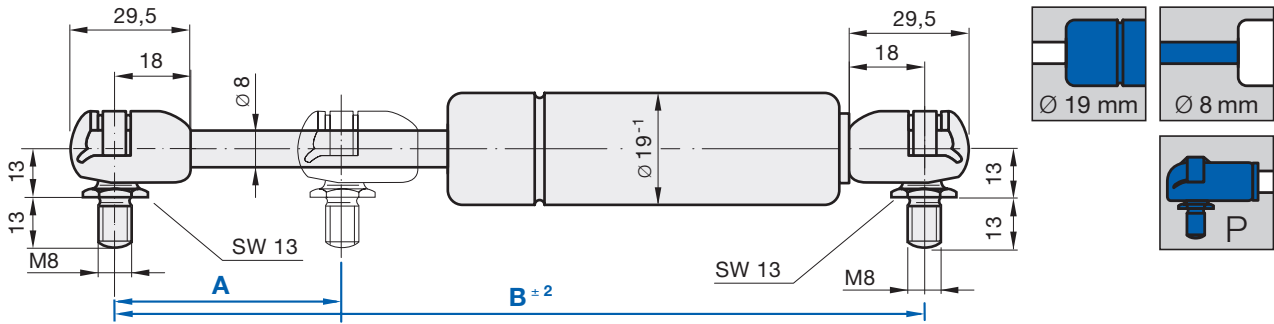

A Hub Stroke Course	B Ausgesch. Länge Extended length Longueur sortie	F ₁ - [N]	Bestell-Nr. Ref.-No. Réf.-No.
60	205	500	094471
		600	083240
		700	083259
		800	094412
80	245	500	083305
		600	083313
		700	083321
		800	094420
100	285	500	083380
		600	083399
		700	083402
		800	094439
120	325	500	094498
		600	083461
		700	083488
		800	094447
140	365	400	083534
		500	083542
		600	083550
		700	083569
160	405	800	094455
		100	083577
		150	095621
		200	083585
		250	095648
		300	083593
		350	095656
		400	083607
		500	083615
		600	083623
		700	083631
		800	094463

A Hub Stroke Course	B Ausgesch. Länge Extended length Longueur sortie	F ₁ - [N]	Bestell-Nr. Ref.-No. Réf.-No.
180	445	100	083658
		150	094501
		200	083666
		250	094528
		300	083674
		350	094536
		400	083682
		500	083690
	445,5	600	083704
		700	083712
		800	094544
		100	083720
200	485	150	094552
		200	083739
		250	094560
		300	083747
		350	094579
		400	083755
		500	083763
		600	083771
		700	083798
		800	094587
220	525	100	083801
		150	094595
		200	083828
		250	094609
		300	083836
		350	094617
		400	083844
		500	083852
		600	083860
		700	083879
	525,5	800	094625
		100	083887
		150	094633
		200	083895
		250	094641
		300	083909
		350	094668
		400	083917
		500	083925
		600	083933
250	585	700	083941
		800	094676
		100	083887
		150	094633
	585,5	200	083895
		250	094641
		300	083909
		350	094668
		400	083917
		500	083925
		600	083933
		700	083941
		800	094676

Maßangaben in mm / Änderungen vorbehalten · Dimensions in mm / We reserve the right to make modifications · Dimensions en mm / Sous réserve de changements
08/04

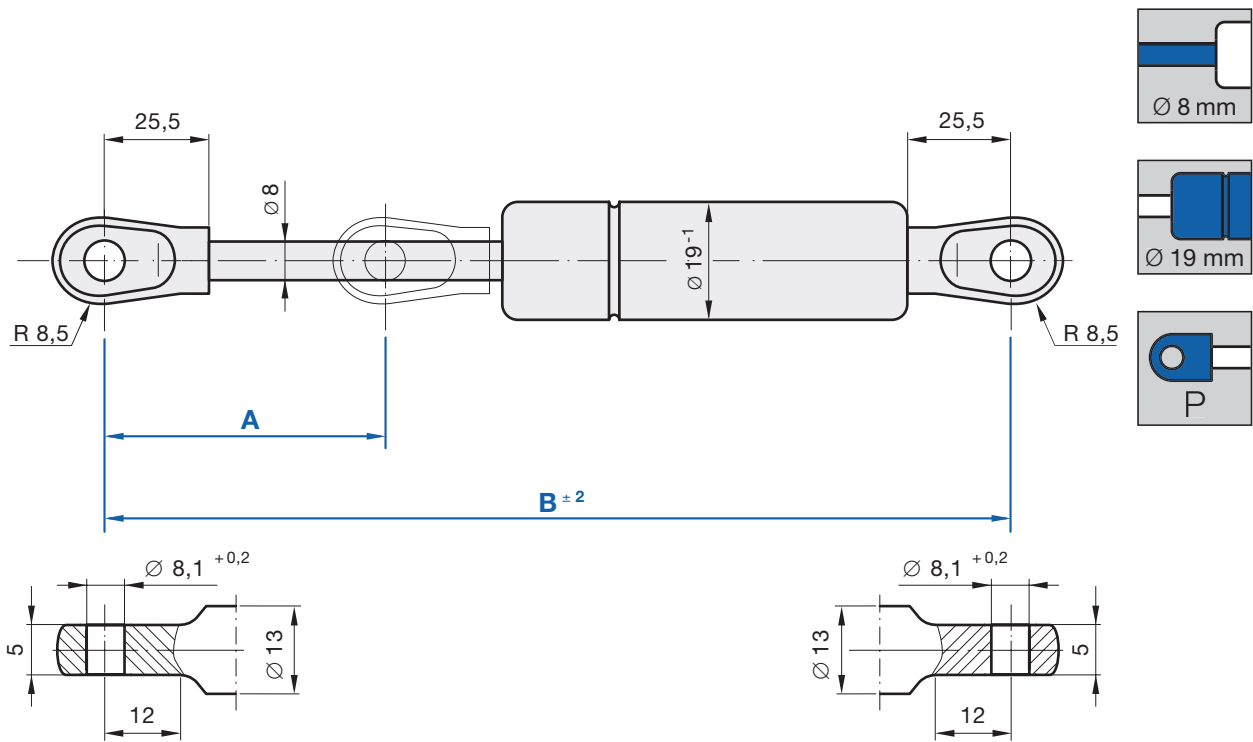

A Hub Stroke Course	B Ausgesch. Länge Extended length Longueur sortie	F ₁ - [N]	Bestell-Nr. Ref.-No. Réf.-No.
60	218,5	500	1929LR
		600	2216LZ
80	258,5	500	1933LO
		600	2217LU
100	298,5	500	1938LQ
		600	2218LP
120	338,5	500	1942LN
		600	2219LK
140	378,5	400	1945LZ
		500	2224LC
		600	2225LY
160	418,5	100	1948LK
		150	2226LT
		200	2227LO
		250	2228LJ
		300	2229LE
		350	2231LL
		400	2232LG
		500	2233LB
		600	2234LX
180	458,5	100	1952LH
		150	2235LS
		200	2236LN
		250	2237LI
		300	2238LD
		350	2239LZ
		400	2241LF
		500	2242LA
		600	2243LW

A Hub Stroke Course	B Ausgesch. Länge Extended length Longueur sortie	F ₁ - [N]	Bestell-Nr. Ref.-No. Réf.-No.
200	498,5	100	1955LT
		150	2244LR
		200	2245LM
		250	2246LH
		300	2247LC
		350	2248LY
220	538,5	400	2249LT
		500	2252LV
		600	2253LQ
		100	1958LE
		150	2255LG
		200	2256LB
250	598,5	250	2257LX
		300	2258LS
		350	2259LN
		400	2261LU
		500	2262LP
		600	2263LK
		100	1817LN
		150	2334LQ
		200	2335LL
		250	2336LG
300	2337LB		
350	2338LX		
400	2339LS		
500	2341LZ		
600	2342LU		

Maßangaben in mm / Änderungen vorbehalten · Dimensions in mm / We reserve the right to make modifications · Dimensions en mm / Sous réserve de changements
08/04

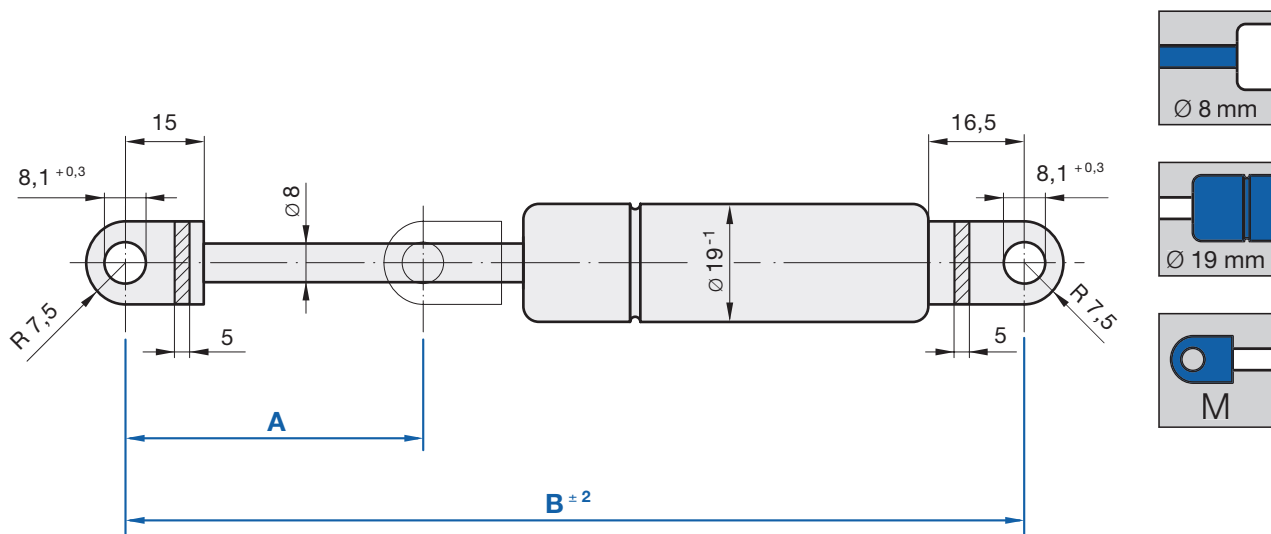

A Hub Stroke Course	B Ausgesch. Länge Extended length Longueur sortie	F ₁ - [N]	Bestell-Nr. Ref.-No. Réf.-No.
60	205	500	084018
		600	084026
	205,5	700	084034
		800	094684
80	245	500	084093
		600	084107
	245,5	700	084115
		800	094692
100	285	500	084174
		600	084182
		700	084190
	800	094706	
120	325	500	084247
		600	094714
		700	084263
	800	094722	
140	365	400	084352
		500	084360
		600	084379
	700	084387	
160	405	700	084492
		800	094757
		100	084395
	180	445	150
200			084409
250			094773
300			084417
350			094781
400			084425
500			084476
600			084484
700			084492
800			094757
350			094838

A Hub Stroke Course	B Ausgesch. Länge Extended length Longueur sortie	F ₁ - [N]	Bestell-Nr. Ref.-No. Réf.-No.
180	445	400	086363
		500	084549
		600	084557
	700	084565	
200	485	800	094846
		100	084573
		150	094854
		200	084581
		250	094862
		300	084603
		350	094870
		400	084611
		500	084638
		600	084646
		700	084654
220	525	800	094889
		100	084662
		150	094897
		200	084670
		250	094900
		300	084689
		350	094919
		400	084697
		500	084700
		600	084719
		700	084727
250	585	800	094927
		100	084735
		150	094935
		200	084743
		250	094943
		300	084751
		350	094951
		400	084778
		500	084786
		600	084794
		700	084808
800	094978		

Maßangaben in mm / Änderungen vorbehalten · Dimensions in mm / We reserve the right to make modifications · Dimensions en mm / Sous réserve de changements
08/04

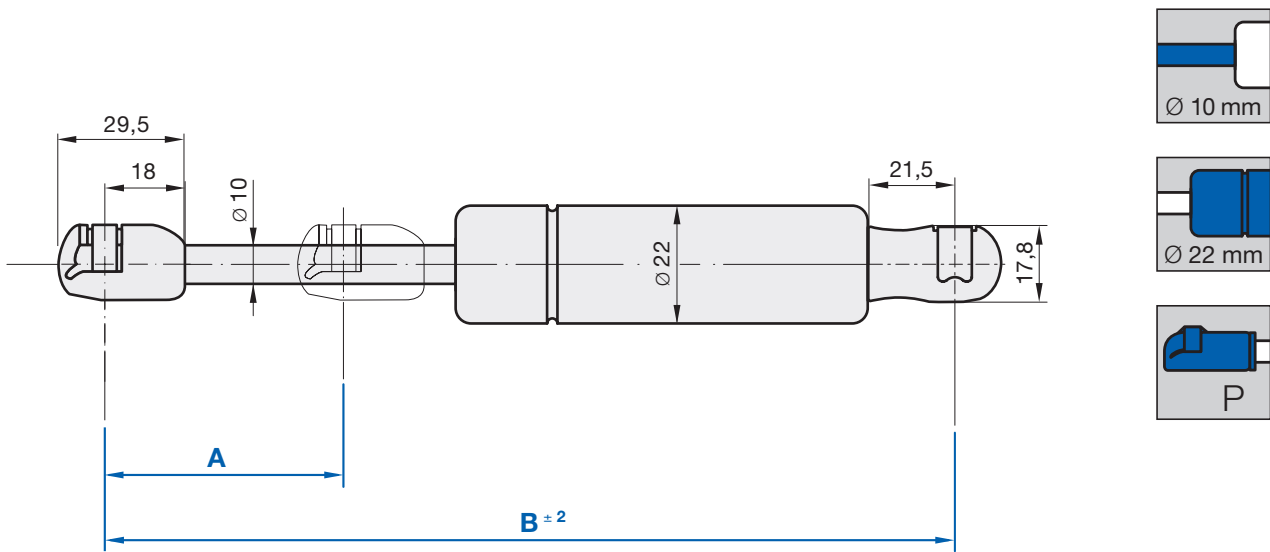

Passend für Kugelzapfen nach DIN 71803 Ø 10
 Suitable for ball studs according to DIN 71803 Ø 10
 Approprié aux rotules mâles selon DIN 71803 Ø 10

A Hub Stroke Course	B Ausgesch. Länge Extended length Longueur sortie	F ₁ - [N]	Bestell-Nr. Ref.-No. Réf.-No.
100	285	900	2666NN
		1000	2667NI
		1150	2668ND
150	385	900	2669NZ
		1000	2671NF
		1150	2672NA
200	485	700	1442EW
		800	1443ER
		900	1444EM
		1000	1445EH
		1150	2673NW
250	585	700	1446EC
		800	1447EY
		900	1448ET
		1000	1449EO
		1150	2674NR
300	685	150	2675NM
		200	3935LP
		250	1438EZ
		300	2677NC
		350	1652CK
		400	753009
		500	2679NT
		600	2682NV
		700	753017
		800	2683NQ
		900	753025
		1000	753033
		1150	2684NL

A Hub Stroke Course	B Ausgesch. Länge Extended length Longueur sortie	F ₁ - [N]	Bestell-Nr. Ref.-No. Réf.-No.
350	785	150	2685NG
		200	2686NB
		250	1439EU
		300	2687NX
		350	2688NS
		400	753041
		500	2689NN
		600	2691NU
400	885	700	753068
		800	2692NP
		900	753076
		1000	753084
		150	2694NF
		200	2695NA
		250	1441EA
		300	2696NW
		350	2697NR
		400	753092
		500	2698NM
		600	2699NH
		700	753106
		800	2701NN

Maßangaben in mm / Änderungen vorbehalten · Dimensions in mm / We reserve the right to make modifications · Dimensions en mm / Sous réserve de changements
 08/04

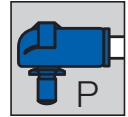
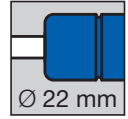
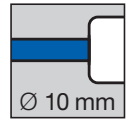
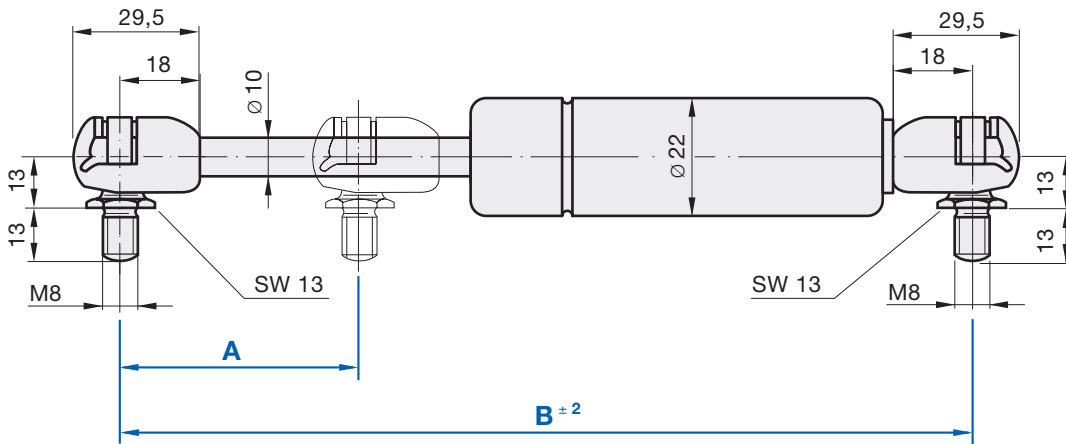

A Hub Stroke Course	B Ausgesch. Länge Extended length Longueur sortie	F ₁ - [N]	Bestell-Nr. Ref.-No. Réf.-No.
100	285	900	085146
		1000	085154
		1150	095303
150	385	900	085189
		1000	085197
		1150	095311
200	485	900	085227
		1000	085235
		1150	095338
250	585	900	085278
		1000	085286
		1150	095346
300	685	150	095354
		200	095362
		250	095370
		300	095389
		350	095397
		400	095400
		500	095419
		600	095427
		700	085294
		800	085308
		900	085316
		1000	085324
1150	095435		

A Hub Stroke Course	B Ausgesch. Länge Extended length Longueur sortie	F ₁ - [N]	Bestell-Nr. Ref.-No. Réf.-No.
350	785	150	095443
		200	095451
		250	095478
		300	095486
		350	095494
		400	095508
		500	095516
400	885	600	095524
		700	085332
		800	085340
		900	085359
		1000	085367
		150	095540
		200	095559
		250	095567
		300	095575
		350	095583
400	095591		
500	095605		
600	095613		
700	085375		
800	085383		

Maßangaben in mm / Änderungen vorbehalten · Dimensions in mm / We reserve the right to make modifications · Dimensions en mm / Sous réserve de changements
08/04

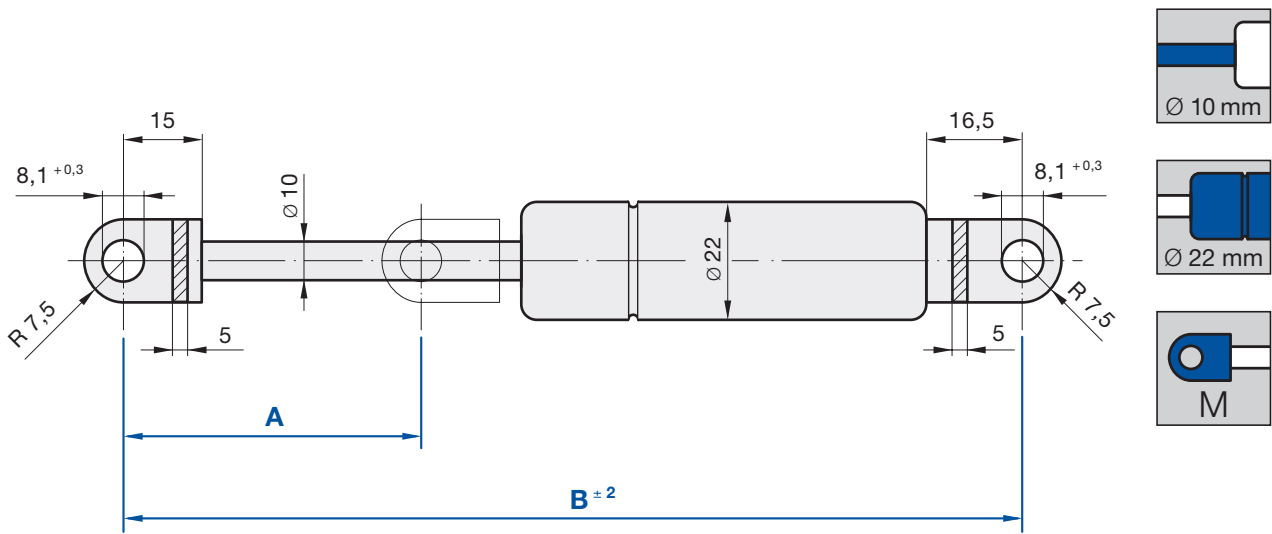

A Hub Stroke Course	B Ausgesch. Länge Extended length Longueur sortie	F ₁ - [N]	Bestell-Nr. Ref.-No. Réf.-No.
95	285	900	084832
		1000	084840
		1150	094986
145	385	900	084875
		1000	084883
		1150	094994
195	485	900	084913
		1000	084921
		1150	095001
245	585	900	084964
		1000	084972
		1150	095028
295	685	150	095036
		200	095044
		250	095052
		300	095060
		350	095079
		400	095087
		500	095095
		600	095109
		700	084980
		800	084999
		900	085014
		1000	085022
		1150	097306

A Hub Stroke Course	B Ausgesch. Länge Extended length Longueur sortie	F ₁ - [N]	Bestell-Nr. Ref.-No. Réf.-No.
345	785	150	095117
		200	095125
		250	095133
		300	095141
		350	095176
		400	095168
		500	095184
		600	095192
		700	085030
		800	085049
395	885	900	085057
		1000	085065
		150	095214
		200	095222
		250	095230
		300	095249
		350	095257
		400	095265
		500	095273
		600	095281
700	085073		
800	086401		

Maßangaben in mm / Änderungen vorbehalten · Dimensions in mm / We reserve the right to make modifications · Dimensions en mm / Sous réserve de changements
08/04

Zubehör
Accessories
Accessoires

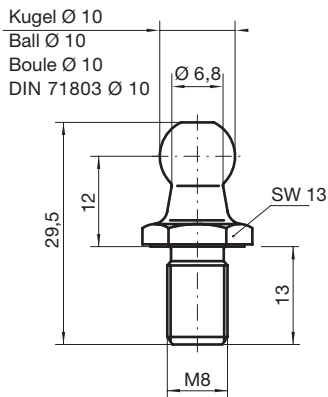

Kugelzapfen / Ball stud / Rotule

Gewinde Thread Filetage	Gewindelänge Thread length Longueur du filetage	Ø-Hals Ø-Neck	Schlüsselweite Spanner width	Bestell-Nr. Ref.-No.
		Ø-Cou	largeur de clé	Réf.-No.
M8	13	6,8	13	022721

Oberfläche	Verzinkt / gelb chromatiert
Surface	Zinc plated / yellow chromated
Surface	Zinguée / Chromatée jaune

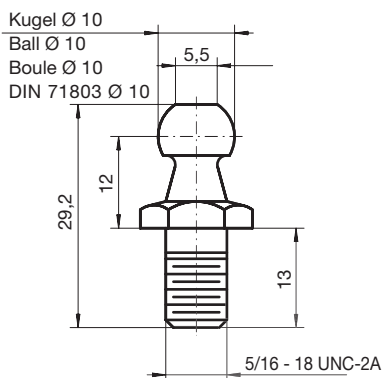

Kugelzapfen / Ball stud / Rotule

Gewinde Thread Filetage	Gewindelänge Thread length Longueur du filetage	Ø-Hals Ø-Neck	Schlüsselweite Spanner width	Bestell-Nr. Ref.-No.
		Ø-Cou	largeur de clé	Réf.-No.
5/16-18 UNC-2A	13	5,5	1/2 Inch	4565BD

Oberfläche	Verzinkt / klar chromatiert
Surface	Zinc plated / clear chromated
Surface	Zinguée / Chromatée claire

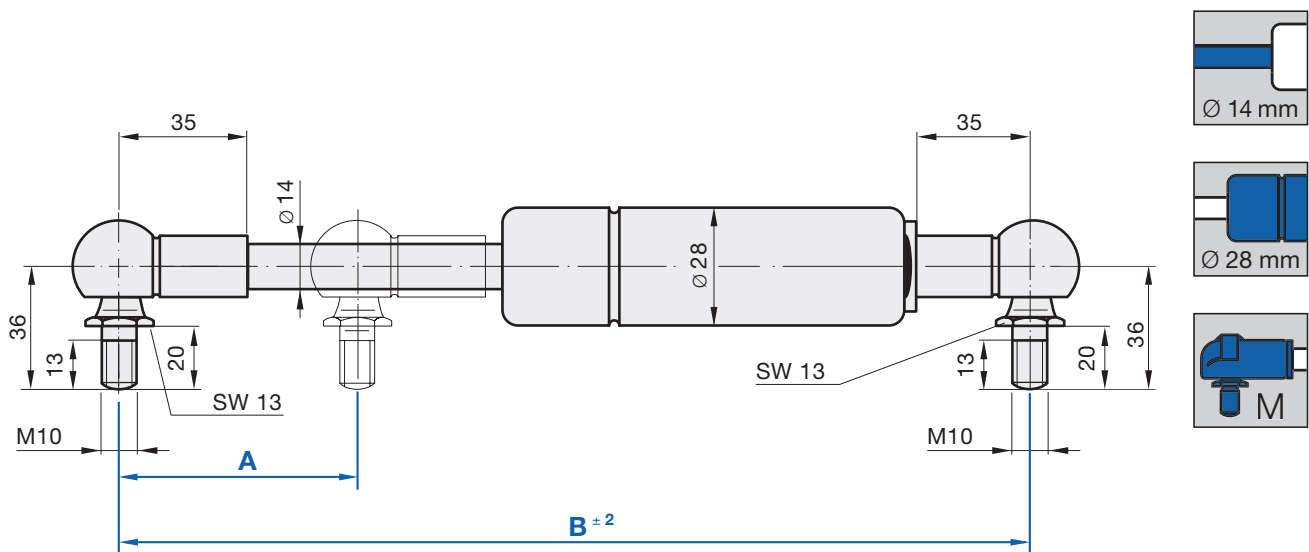

A Hub Stroke Course	B Ausgesch. Länge Extended length Longueur sortie	F ₁ - [N]	Bestell-Nr. Ref.-No. Réf.-No.
100	335,5	1300	2029LS
		1500	2357LQ
		1700	2358LL
		1900	2359LG
		2100	2361LN
150	435,5	1300	2033LP
		1500	2362LI
		1700	2363LD
		1900	2364LZ
		2100	2365LU
200	535,5	1300	2036LA
		1500	2366LP
		1700	2367LK
		1900	2368LF
		2100	2369LA
250	635,5	1300	2075LI
		1500	2371LH
		1700	2372LC
		1900	2373LY
		2100	2374LT
300	735,5	1300	2078LU
		1500	2375LO
		1700	2376LJ
		1900	2377LE
		2100	2379LV

A Hub Stroke Course	B Ausgesch. Länge Extended length Longueur sortie	F ₁ - [N]	Bestell-Nr. Ref.-No. Réf.-No.
350	835,5	1300	2082LR
		1500	2381LB
		1700	2382LX
		1900	2383LS
		2100	2384LN
		2384LN	
400	935,5	1300	2085LC
		1500	2385LI
		1700	2386LD
		1900	2387LZ
		2100	2388LU
500	1135,5	500	2088LO
		600	2389LP
		700	2391LW
		800	2392LR
		900	2393LM
		1000	2394LH
		1100	2395LC
		1300	2396LY
		1500	2397LT
		1700	2398LO

Maßangaben in mm / Änderungen vorbehalten · Dimensions in mm / We reserve the right to make modifications · Dimensions en mm / Sous réserve de changements
08/04

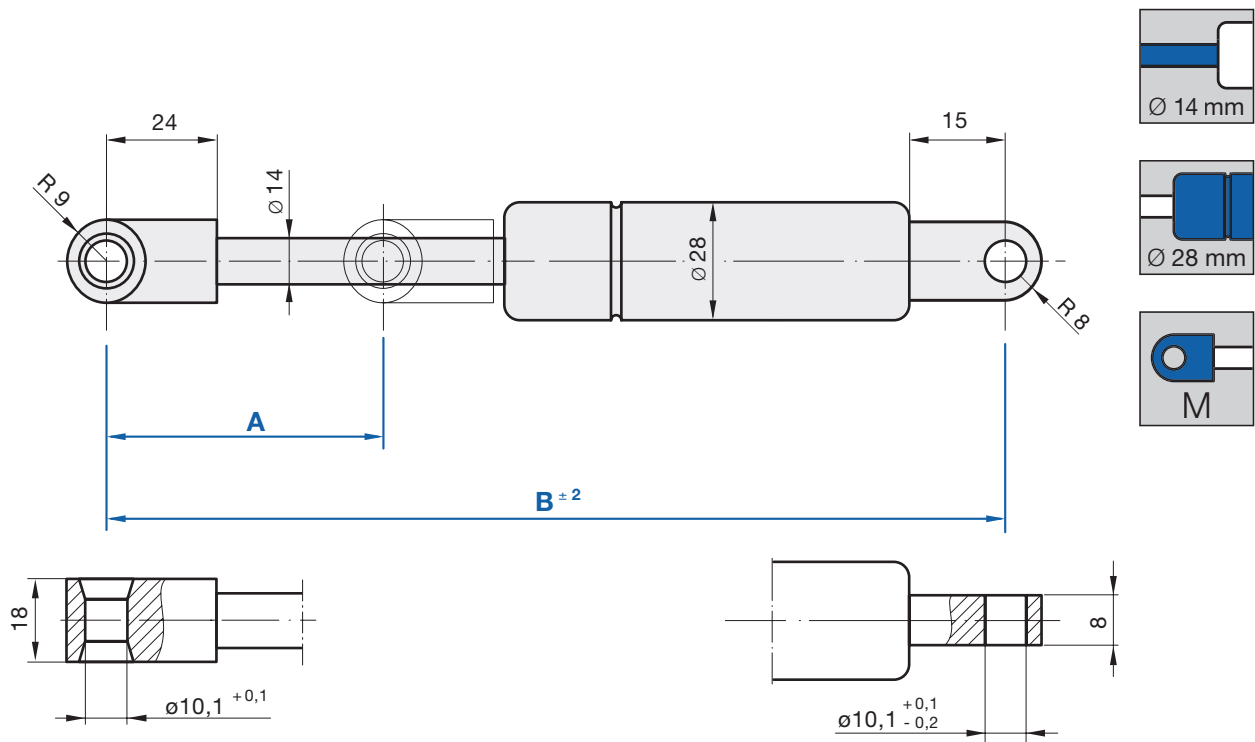

A Hub Stroke Course	B Ausgesch. Länge Extended length Longueur sortie	F ₁ - [N]	Bestell-Nr. Ref.-No. Réf.-No.
100	302	1300	1847LW
		1500	2038LR
		1700	2039LM
		1900	2041LT
		2100	2042LO
150	402	1300	1851LT
		1500	2043LJ
		1700	2044LE
		1900	2046LV
		2100	2047LQ
200	502	1300	1854LE
		1500	2048LL
		1700	2049LG
		1900	2051LN
		2100	2052LI
250	602	1300	1858LL
		1500	2055LU
		1700	2056LP
		1900	2057LK
		2100	2058LF
300	702	1300	1862LI
		1500	2059LA
		1700	2061LH
		1900	2062LC
		2100	2063LY

A Hub Stroke Course	B Ausgesch. Länge Extended length Longueur sortie	F ₁ - [N]	Bestell-Nr. Ref.-No. Réf.-No.
350	802	1300	1865LU
		1500	2064LT
		1700	2065LO
		1900	2066LJ
		2100	2067LE
400	902	1300	1868LF
		1500	2069LV
		1700	2071LB
		1900	2072LX
		2100	2073LS
500	1102	500	1872LC
		600	2108LB
		700	2109LX
		800	2111LD
		900	2112LZ
		1000	2113LU
		1100	2114LP
		1300	2115LK
		1500	2116LF
1700	2117LA		
1900	2118LW		

Maßangaben in mm / Änderungen vorbehalten · Dimensions in mm / We reserve the right to make modifications · Dimensions en mm / Sous réserve de changements
08/04

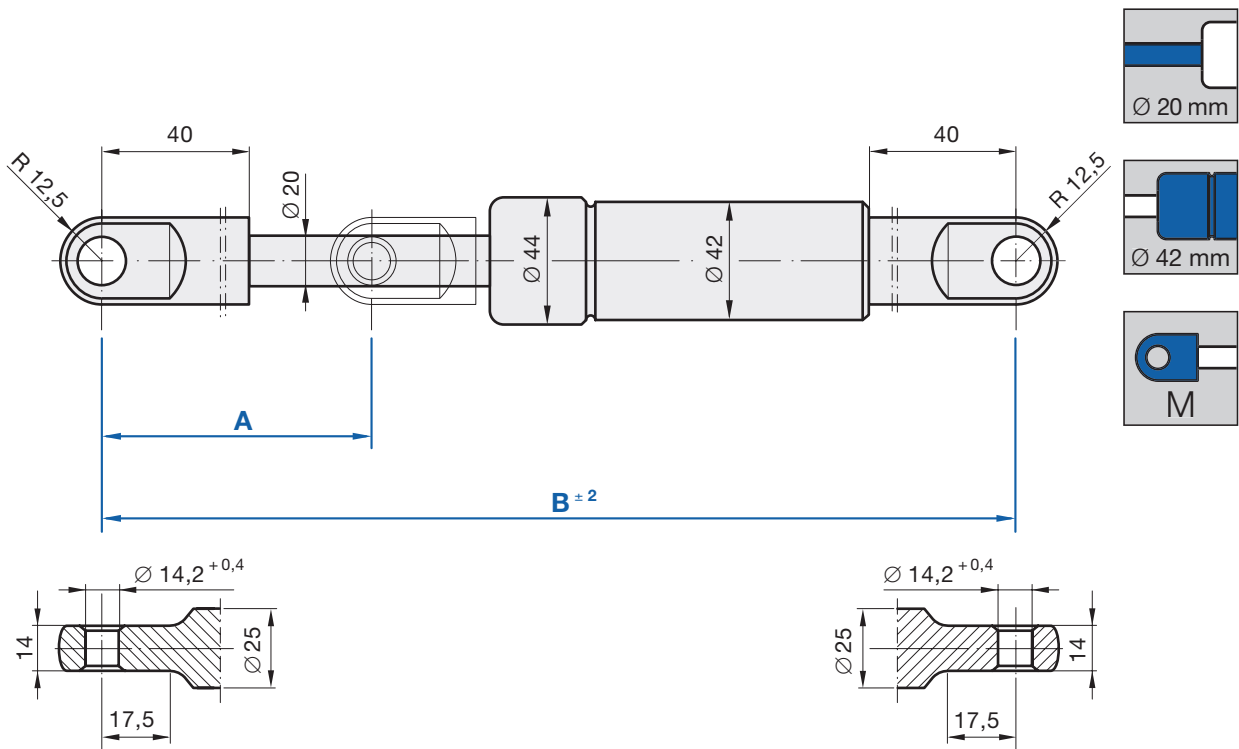

A Hub Stroke Course	B Ausgesch. Länge Extended length Longueur sortie	F ₁ - [N]	Bestell-Nr. Ref.-No. Réf.-No.
150	500	2400	095974
		2800	095982
		3200	207519
		3600	207527
		4000	155624
		4600	207535
200	600	5200	207543
		2400	086657
		2800	086665
		3200	207462
		3600	207470
		4000	207489
250	700	4600	207497
		5200	207500
		2400	086738
		2800	086746
		3200	207551
		3600	207578
300	800	4000	207586
		4600	207594
		5200	207608
		2400	086789
		2800	086800
		3200	207616
		3600	207624

A Hub Stroke Course	B Ausgesch. Länge Extended length Longueur sortie	F ₁ - [N]	Bestell-Nr. Ref.-No. Réf.-No.
300	800	4000	207632
		4600	207640
		5200	207659
350	900	2400	096083
		2800	096091
		3200	207667
		3600	207675
		4000	207683
		4600	207691
400	1000	5200	207705
		2400	086924
		2800	086932
		3200	207713
500	1200	3600	207721
		4000	207748
		4600	207756
		5200	207764
		2400	086983
		2800	086991
		3200	207772
		3600	207780
		4000	207799
		4600	207802
		5200	207810

Maßangaben in mm / Änderungen vorbehalten · Dimensions in mm / We reserve the right to make modifications · Dimensions en mm / Sous réserve de changements
08/04

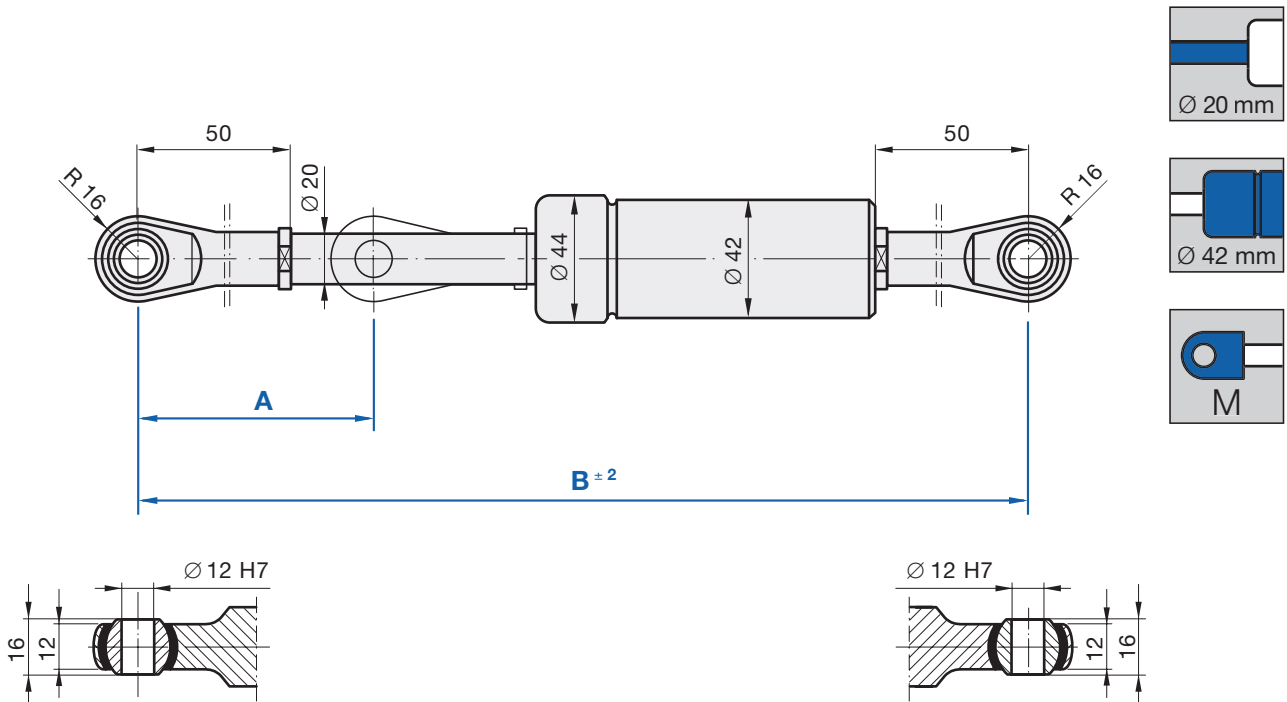

A Hub Stroke Course	B Ausgesch. Länge Extended length Longueur sortie	F ₁ - [N]	Bestell-Nr. Ref.-No. Réf.-No.
150	520	2400	087041
		2800	087068
		3200	207829
		3600	207837
		4000	207845
		4600	207853
200	620	5200	207861
		2400	087114
		2800	087122
		3200	207888
		3600	207896
		4000	207918
250	720	4600	207926
		5200	207934
		2400	087173
		2800	087181
		3200	207942
		3600	207950
300	820	4000	207969
		4600	207977
		5200	207985
		2400	087254
		2800	087262
		3200	207993
		3600	208000

A Hub Stroke Course	B Ausgesch. Länge Extended length Longueur sortie	F ₁ - [N]	Bestell-Nr. Ref.-No. Réf.-No.
300	820	4000	208019
		4600	208027
		5200	208035
350	920	2400	087319
		2800	087327
		3200	208043
		3600	208051
		4000	208078
		4600	208086
400	1020	5200	208094
		2400	087386
		2800	087394
		3200	208108
500	1220	3600	208116
		4000	208124
		4600	208132
		5200	208140
		2400	087440
		2800	087459
		3200	208159
		3600	208167
		4000	208175
		4600	208183
		5200	208191

Maßangaben in mm / Änderungen vorbehalten · Dimensions in mm / We reserve the right to make modifications · Dimensions en mm / Sous réserve de changements
08/04

Gasfeder-Ergänzungsprogramm 8/19
Gas spring assembly programme 8/19
Programme modulaire pour ressorts à gaz 8/19

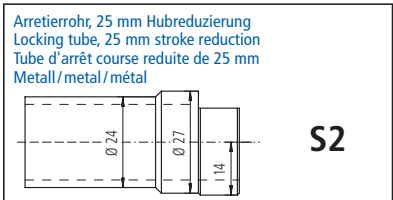
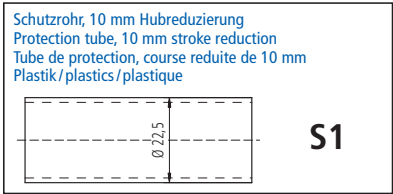
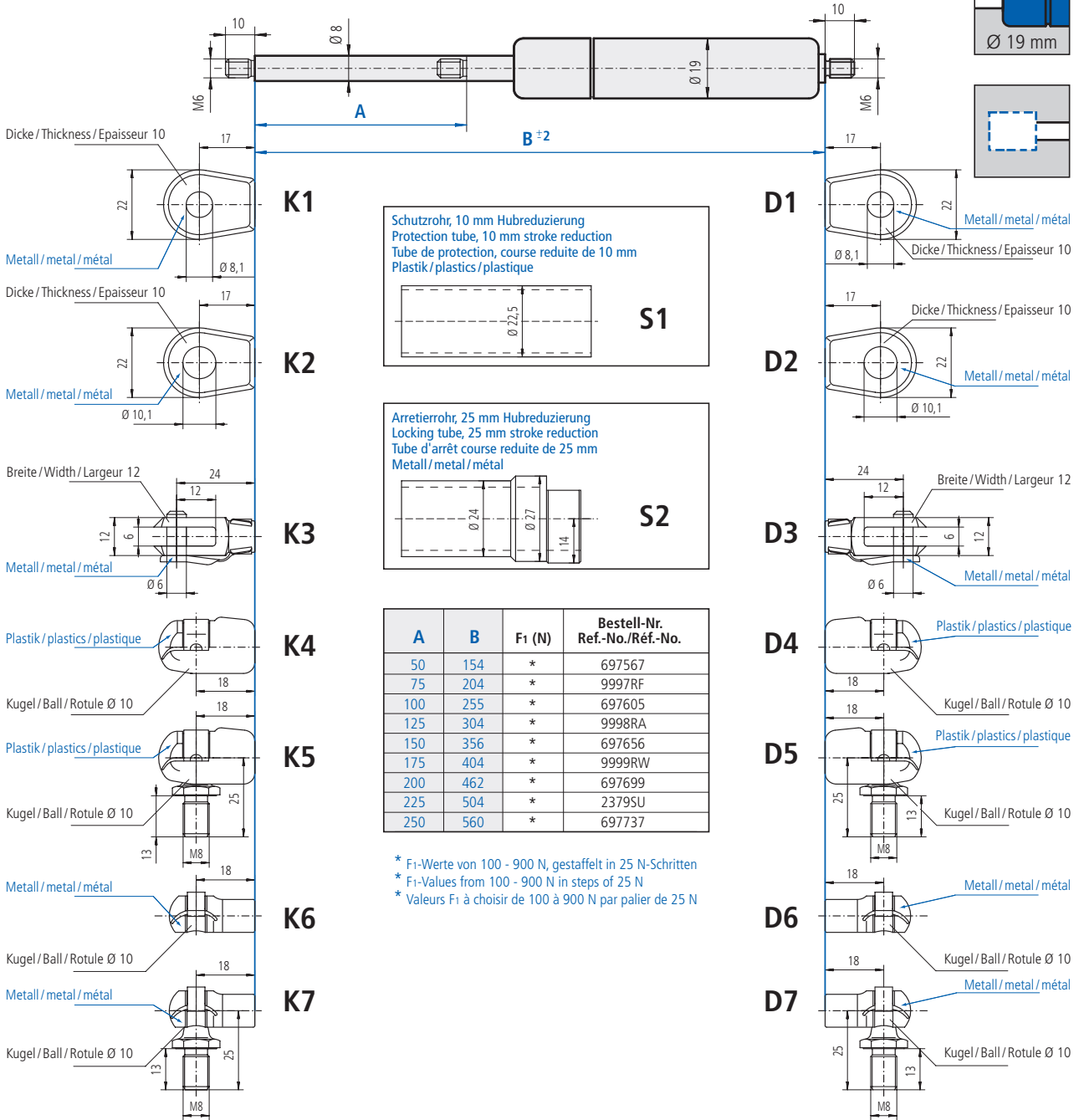
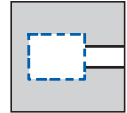
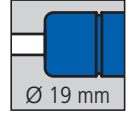
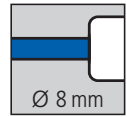

A	B	F ₁ (N)	Bestell-Nr. Ref.-No./Réf.-No.
50	154	*	697567
75	204	*	9997RF
100	255	*	697605
125	304	*	9998RA
150	356	*	697656
175	404	*	9999RW
200	462	*	697699
225	504	*	2379SU
250	560	*	697737

* F₁-Werte von 100 - 900 N, gestaffelt in 25 N-Schritten
 * F₁-Values from 100 - 900 N in steps of 25 N
 * Valeurs F₁ à choisir de 100 à 900 N par palier de 25 N

Bestell-Beispiel / Ordering example / Exemple de commande

123456 / 0350N / K2 / D1 / S1

Bestell-Nr. Ref.-No. Réf.-No.	F₁	Kolbenstangen-Anschluss Piston rod end fitting Attache côté tige	Druckrohr-Anschluss Pressure tube end fitting Attache côté tube	Schutzrohr Protection tube Tube de protection
-------------------------------------	----------------------	--	---	---

Montage nach STAB-Spec.10005630 / Installation according to STAB-Spec.10005630 / Montage suivant STAB-Spec.10005630

Maßangaben in mm / Änderungen vorbehalten · Dimensions in mm / We reserve the right to make modifications · Dimensions en mm / Sous réserve de changements 08/04

Gasfeder-Ergänzungsprogramm 10/22
Gas spring assembly programme 10/22
Programme modulaire pour ressorts à gaz 10/22

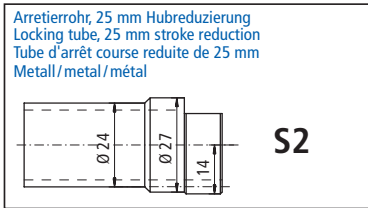
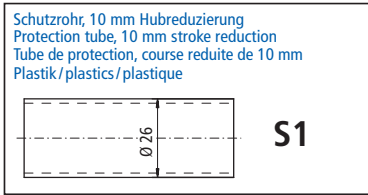
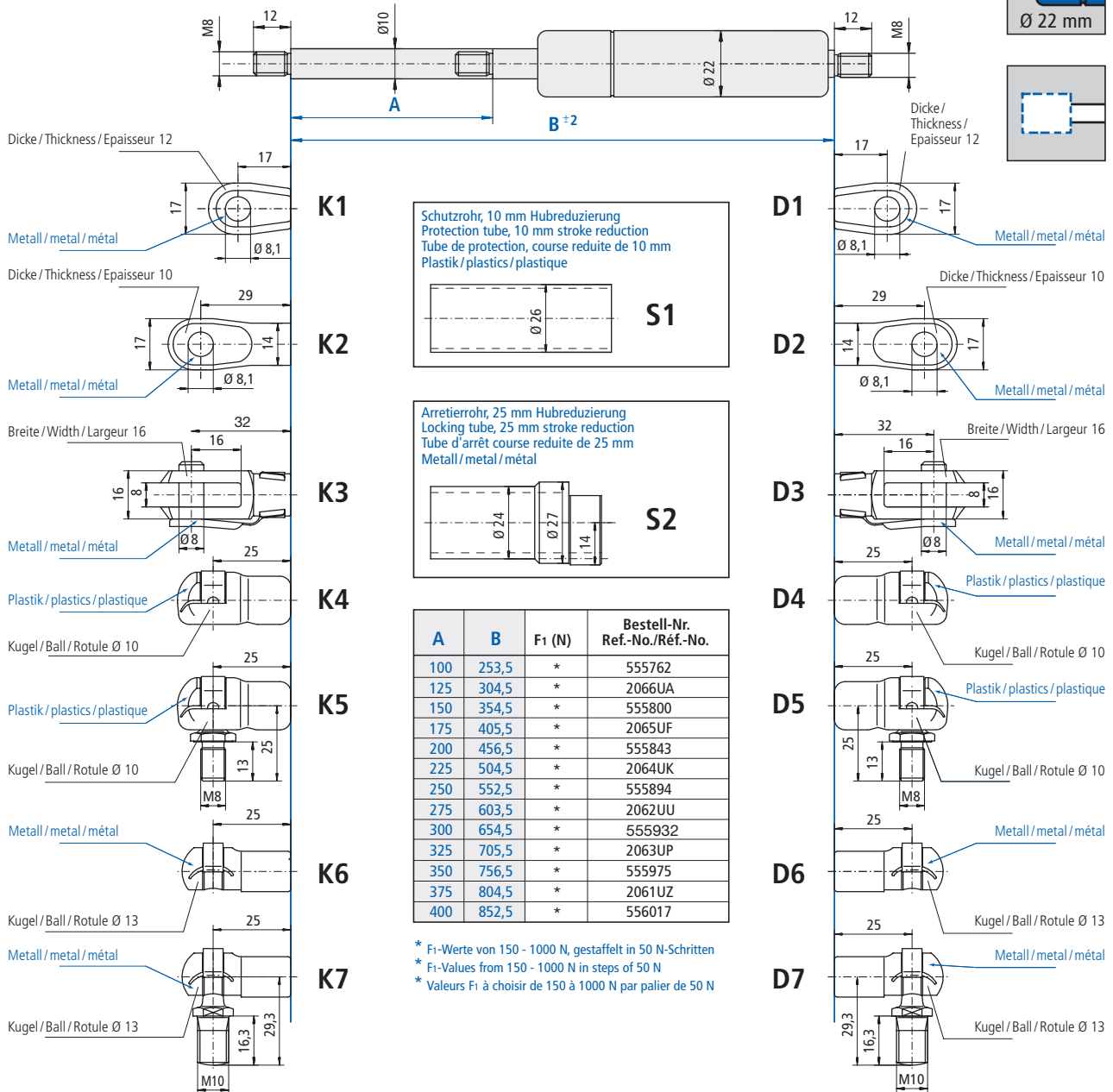
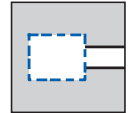
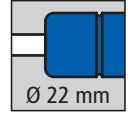
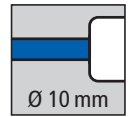

A	B	F1 (N)	Bestell-Nr. Ref.-No./Réf.-No.
100	253,5	*	555762
125	304,5	*	2066UA
150	354,5	*	555800
175	405,5	*	2065UF
200	456,5	*	555843
225	504,5	*	2064UK
250	552,5	*	555894
275	603,5	*	2062UU
300	654,5	*	555932
325	705,5	*	2063UP
350	756,5	*	555975
375	804,5	*	2061UZ
400	852,5	*	556017

* F1-Werte von 150 - 1000 N, gestaffelt in 50 N-Schritten
 * F1-Values from 150 - 1000 N in steps of 50 N
 * Valeurs F1 à choisir de 150 à 1000 N par palier de 50 N

Bestell-Beispiel / Ordering example / Exemple de commande

123456 / 0350N / K2 / D1 / S1

Bestell-Nr. Ref.-No. Réf.-No.	F1	Kolbenstangen-Anschluss Piston rod end fitting Attache côté tige	Druckrohr-Anschluss Pressure tube end fitting Attache côté tube	Schutzrohr Protection tube Tube de protection
-------------------------------------	----	--	---	---

Montage nach STAB-Spec.10005625 / Installation according to STAB-Spec.10005625 / Montage suivant STAB-Spec.10005625

Maßangaben in mm / Änderungen vorbehalten · Dimensions in mm / We reserve the right to make modifications · Dimensions en mm / Sous réserve de changements 08/04

Gasfeder-Ergänzungsprogramm 14/28
Gas spring assembly programme 14/28
Programme modulaire pour ressorts à gaz 14/28

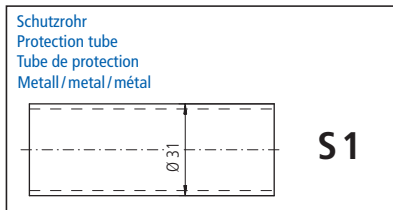
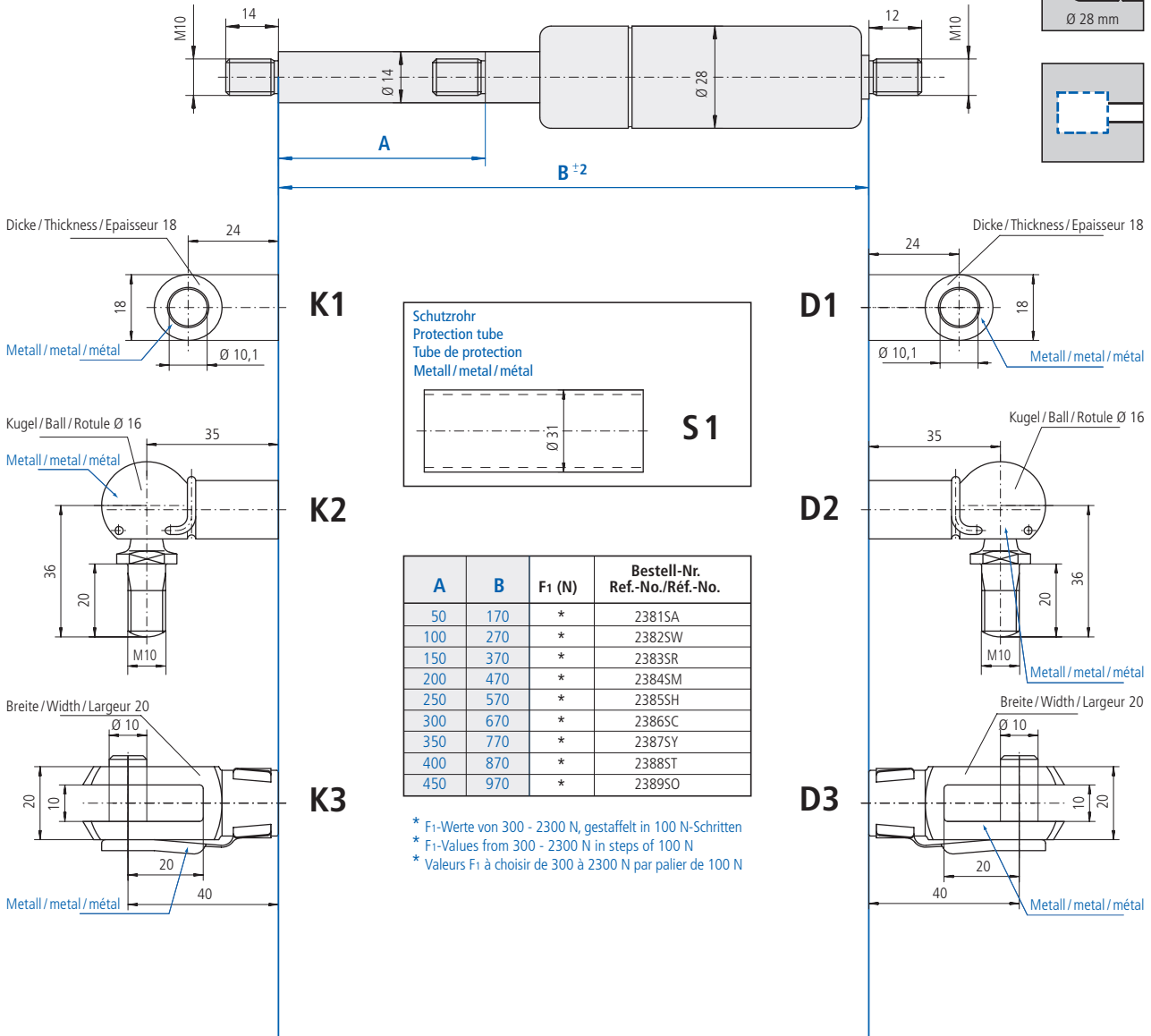
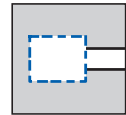
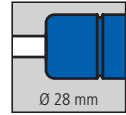
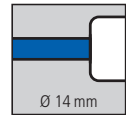

A	B	F ₁ (N)	Bestell-Nr. Ref.-No./Réf.-No.
50	170	*	2381SA
100	270	*	2382SW
150	370	*	2383SR
200	470	*	2384SM
250	570	*	2385SH
300	670	*	2386SC
350	770	*	2387SY
400	870	*	2388ST
450	970	*	2389SO

* F₁-Werte von 300 - 2300 N, gestaffelt in 100 N-Schritten
 * F₁-Values from 300 - 2300 N in steps of 100 N
 * Valeurs F₁ à choisir de 300 à 2300 N par palier de 100 N

Bestell-Beispiel / Ordering example / Exemple de commande

123456 / 0350N / K2 / D1 / S1

Bestell-Nr. Ref.-No. Réf.-No.	F1	Kolbenstangen-Anschluss Piston rod end fitting Attache côté tige	Druckrohr-Anschluss Pressure tube end fitting Attache côté tube	Schutzrohr Protection tube Tube de protection
-------------------------------------	----	--	---	---

Montage nach STAB-Spec.10021385 / Installation according to STAB-Spec.10021385 / Montage suivant STAB-Spec.10021385

Maßangaben in mm / Änderungen vorbehalten · Dimensions in mm / We reserve the right to make modifications · Dimensions en mm / Sous réserve de changements 08/04

Notizen / Notes / Notes

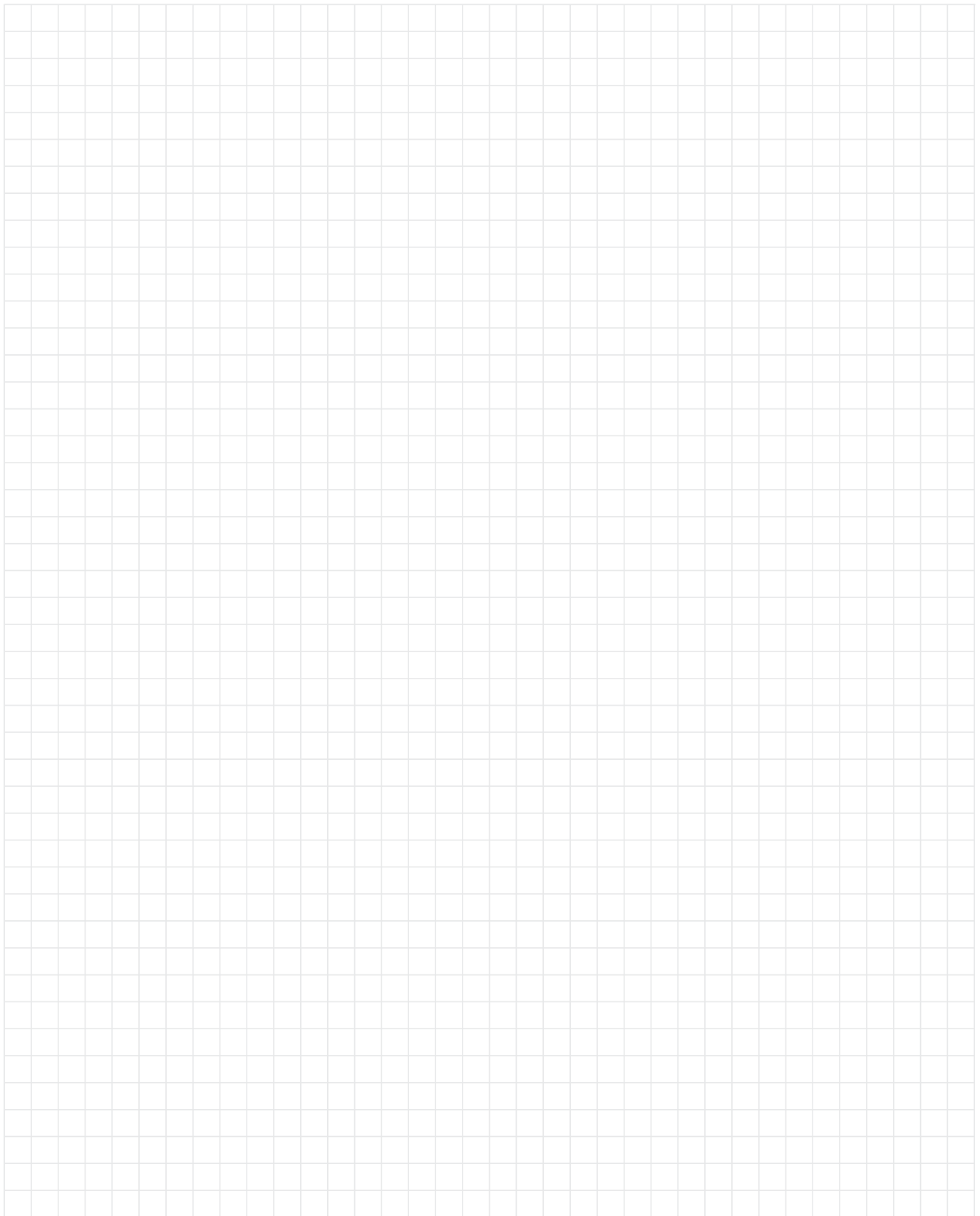

Notizen / Notes / Notes

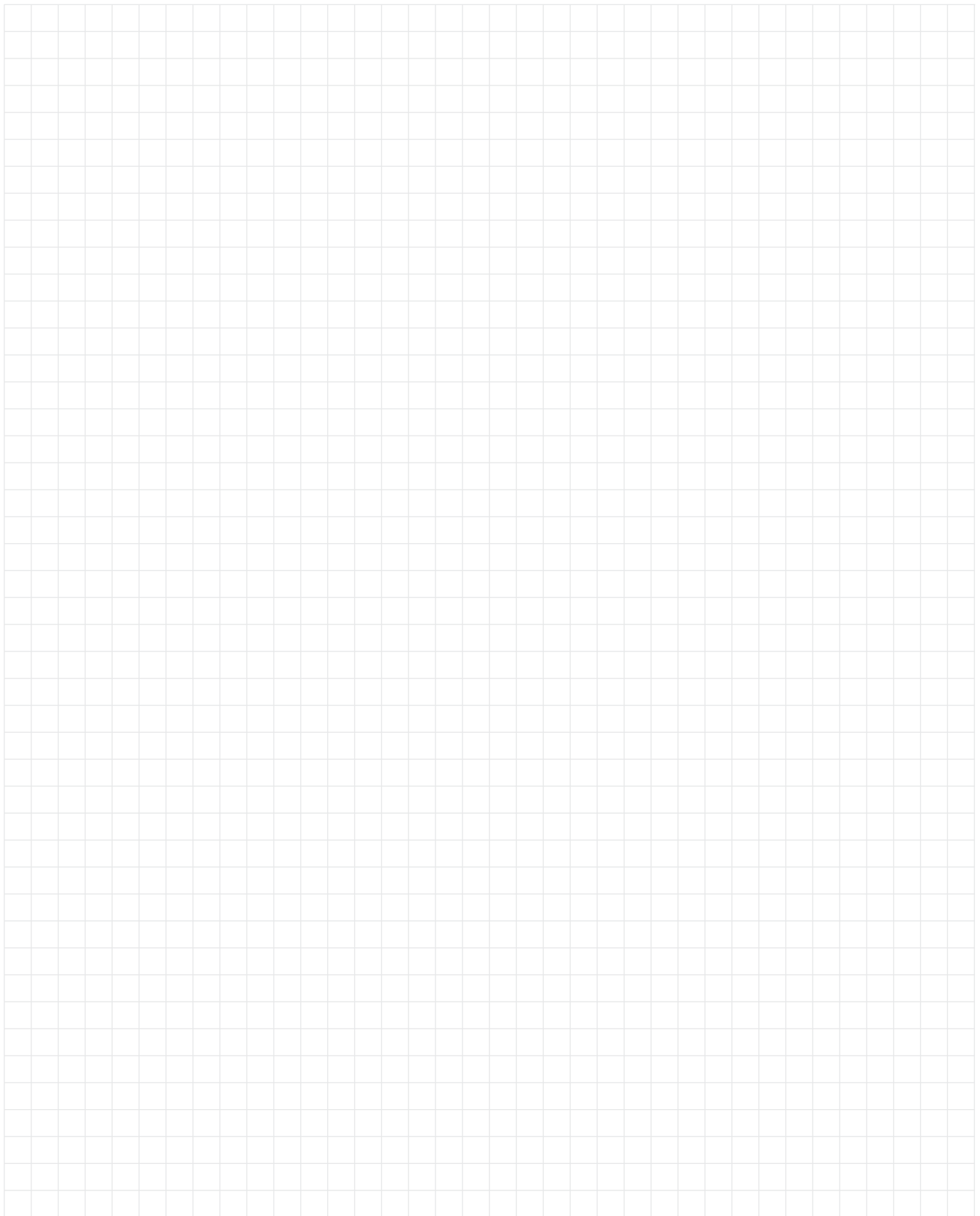

Notizen / Notes / Notes

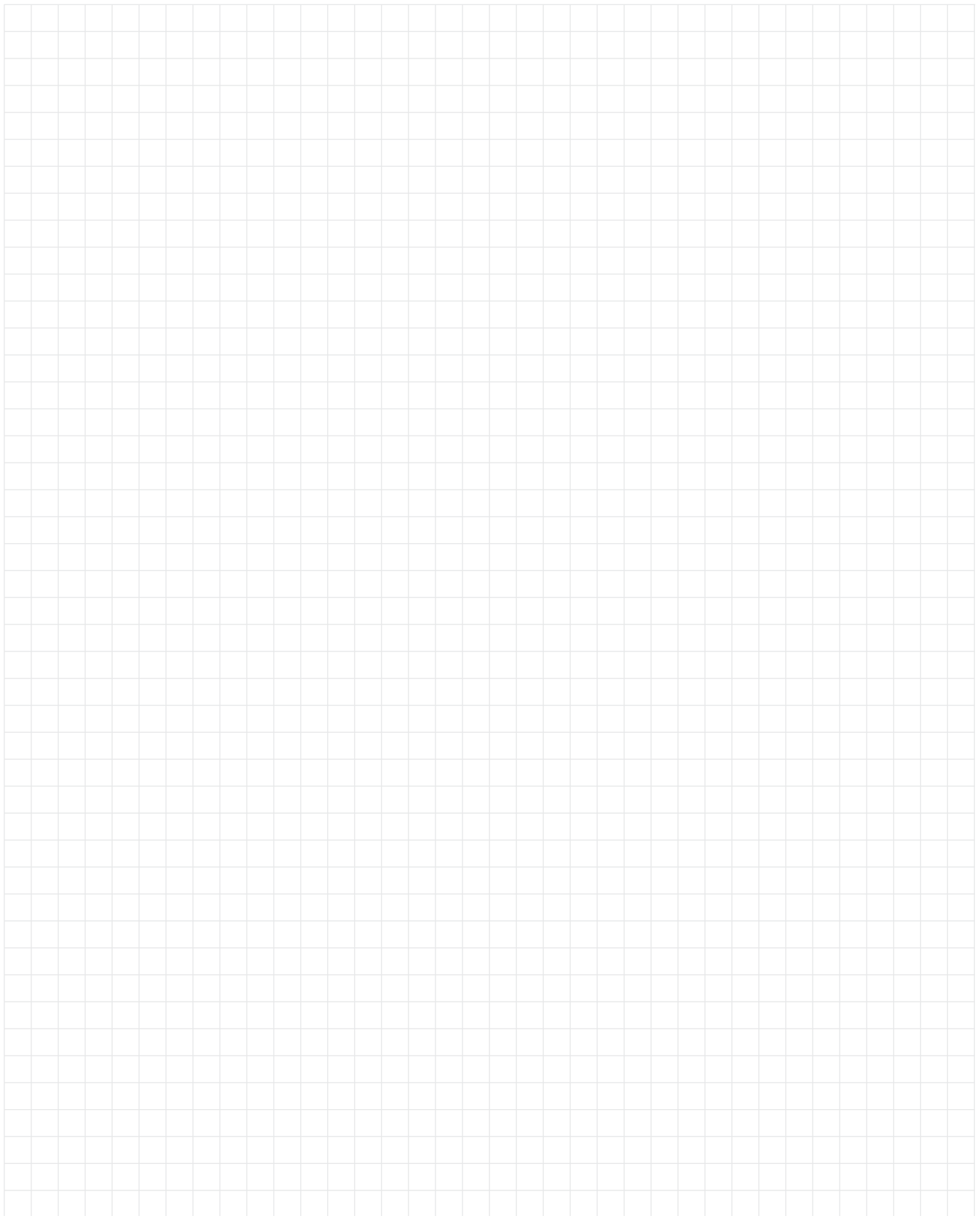



INDEX

							Seite Page Page
<input type="checkbox"/>			<input type="checkbox"/>		<input type="checkbox"/>	2,5	34
<input type="checkbox"/>			<input type="checkbox"/>		<input type="checkbox"/>	2,5	35
<input type="checkbox"/>			<input type="checkbox"/>		<input type="checkbox"/>	1	36
<input type="checkbox"/>			<input type="checkbox"/>			2,5	37
<input type="checkbox"/>			<input type="checkbox"/>			1	38
	<input type="checkbox"/>		<input type="checkbox"/>		<input type="checkbox"/>	2,5	39
	<input type="checkbox"/>		<input type="checkbox"/>		<input type="checkbox"/>	1	40
	<input type="checkbox"/>		<input type="checkbox"/>			2,5	41
	<input type="checkbox"/>		<input type="checkbox"/>			1	42
		<input type="checkbox"/>		<input type="checkbox"/>	<input type="checkbox"/>	2,5	43
		<input type="checkbox"/>	<input type="checkbox"/>		<input type="checkbox"/>	2,5	44
		<input type="checkbox"/>	<input type="checkbox"/>		<input type="checkbox"/>	1	45

Zubehör Seite 46
 Accessories Page 46
 Accessories Page 46

BLOC-O-LIFT®

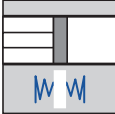
Stufenlos verstellen, starr oder federnd blockieren.
 Variable positioning, rigid or spring blocking.
 Réglage en continu, blocage rigide ou élastique.

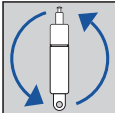
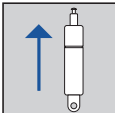
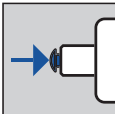
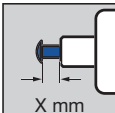
<p>Federnde Blockierung Springing blocking Blocage élastique</p>	
<p>Starre Blockierung in Zugrichtung Rigid blocking in extension Blocage rigide dans le sens de détente</p>	
<p>Starre Blockierung in Druckrichtung Rigid blocking in compr. Blocage rigide dans le sens de compression</p>	
<p>Einbaulage beliebig Installation position any as required Position de montage aux choix</p>	
<p>Kolbenstange nach oben With piston rod upwards Avec tige vers le haut</p>	
<p>für Dauerauslösung geeignet Suitable for perm. release Propre à déclenchement permanent</p>	
<p>Auslöseweg Release way Course de déclenchement</p>	

BLOC-O-LIFT®

Notizen / Notes / Notes

A large grid of graph paper for taking notes, consisting of 20 columns and 30 rows of small squares.

Technische Informationen
 Technical information
 Information technique

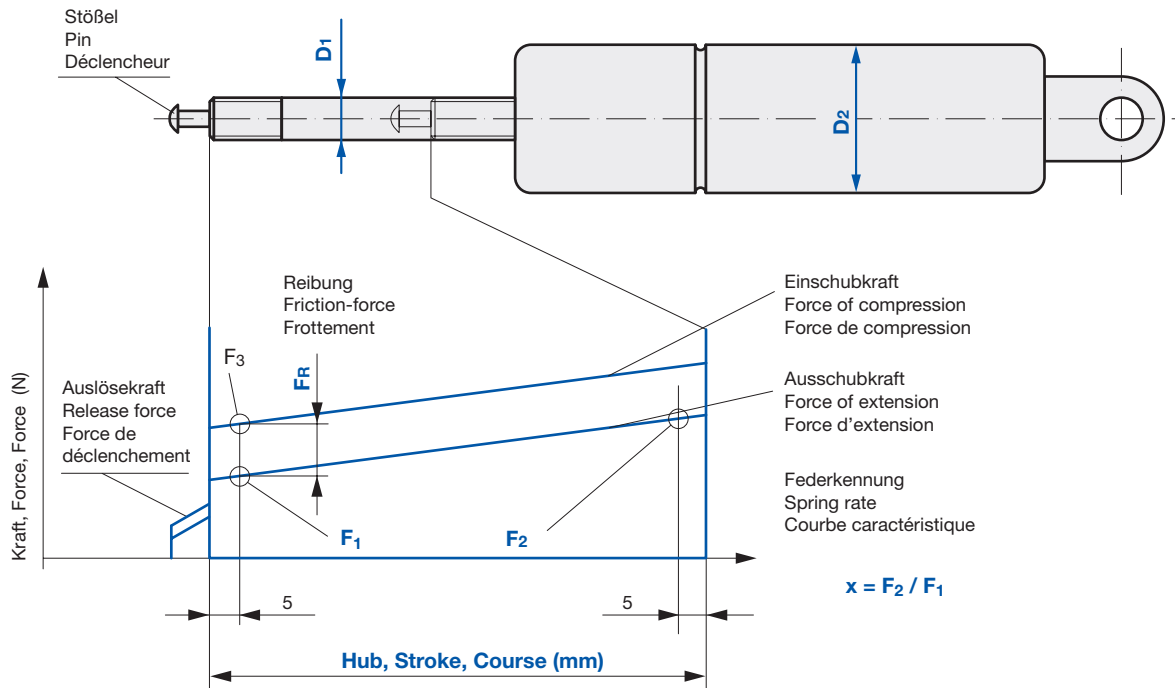

D1 (mm)	D2 (mm)	Ausschubkraft Force of extension Force d'extension F1 (N)		X (≈)	FR max. (N)	Auslösekraft Release force Force de déclenchement
		min.	max.			
8	28	200-1000		1,01-1,5	80	ca. 30 % F1
10	28	200-1200		1,01-1,6	80	ca. 18 % F1

Einbauvorschrift
 Installation instruction
 Instruction de montage **STAB-Spec. 1000 5593**

Ventilauslösekraft nach
 Release force of calve according
 Force d'ouverture de la soupape selon **STAB-Spec. 1000 5233**

Statische Messung der Kräfte
 Statically measured forces
 Forces mesurées statiquement **STAB-Spec. 1000 9033**

Entsorgungsvorschrift
 Disposal instruction
 Instruction de neutralisation **STAB-Spec. 1000 9375**
www.stabilus.com/recycling

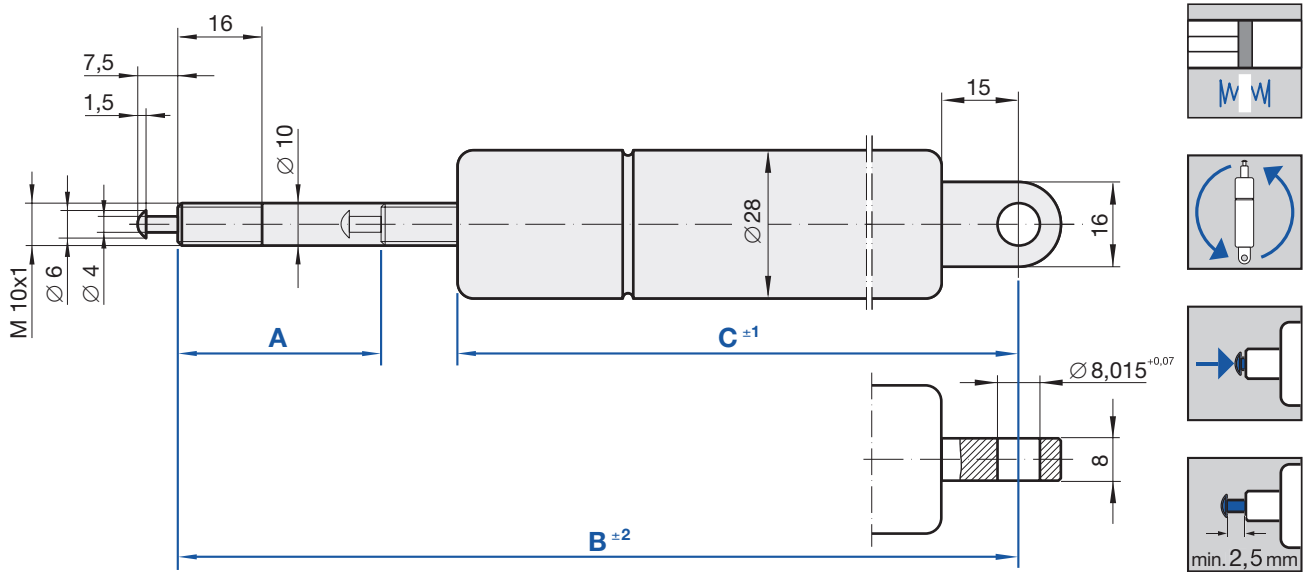

A Hub Stroke Course	B Ausgesch. Länge Extended length Longueur sortie	C Druckrohrlänge Length of pressure tube Longueur du tube de pression	F ₁ - [N]	Bestell-Nr. Ref.-No. Réf.-No.
20,0	149,5	111,5	300	670685
			350	728543
			400	728594
			500	670626
			600	728640
			800	691860
			1000	728659
			1200	728667
25,0	157,5	116,5	250	681830
			300	728675
			350	728683
			400	728705
			500	691879
			600	728713
			800	691887
			1000	728721
1200	728748			

A Hub Stroke Course	B Ausgesch. Länge Extended length Longueur sortie	C Druckrohrlänge Length of pressure tube Longueur du tube de pression	F ₁ - [N]	Bestell-Nr. Ref.-No. Réf.-No.
30,0	168,5	121,5	250	681849
			300	728756
			350	728764
			400	728772
			500	691895
			600	728780
			800	691909
			1000	728799
			1200	728802
			40,0	187,5
250	728810			
300	728829			
350	728837			
400	728845			
500	691917			
600	728853			
800	691925			
1000	728861			
1200	728888			

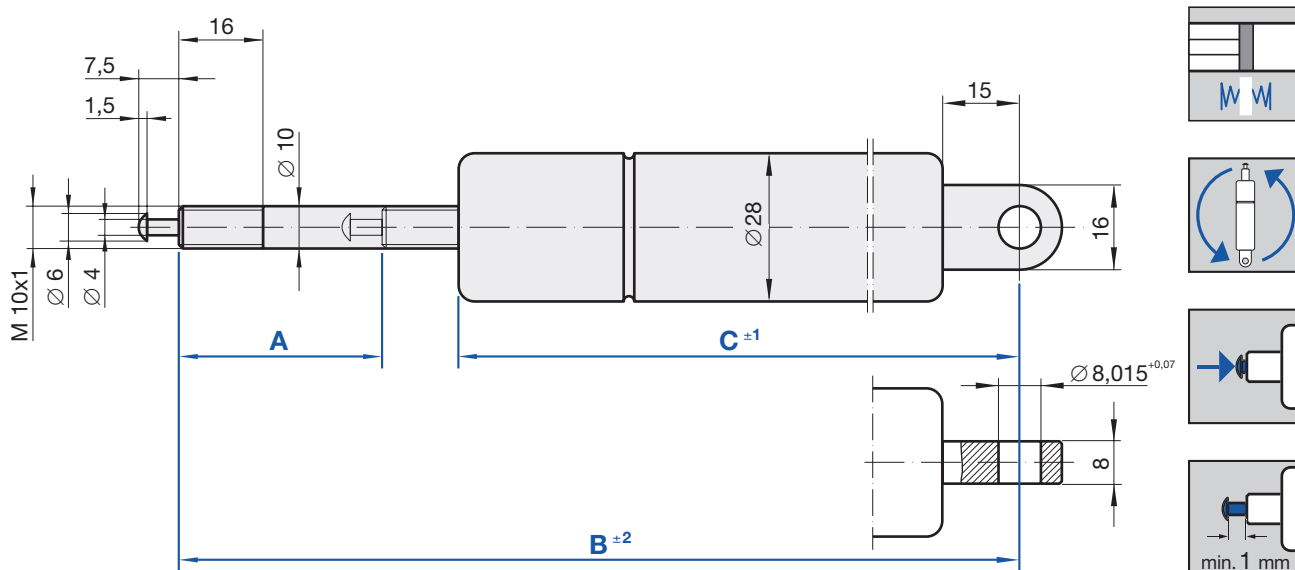

A Hub Stroke Course	B Ausgesch. Länge Extended length Longueur sortie	C Druckrohrlänge Length of pressure tube Longueur du tube de pression	F ₁ - [N]	Bestell-Nr. Ref.-No. Réf.-No.
20,0	149,5	111,5	300	681954
			350	729892
			400	729906
			500	692263
			600	729914
			800	692271
			1000	729922
			1200	729930
25,0	157,5	116,5	250	681962
			300	729949
			350	729957
			400	729965
			500	692298
			600	729981
			800	692301
			1000	730009
1200	730017			

A Hub Stroke Course	B Ausgesch. Länge Extended length Longueur sortie	C Druckrohrlänge Length of pressure tube Longueur du tube de pression	F ₁ - [N]	Bestell-Nr. Ref.-No. Réf.-No.
30,0	168,5	121,5	250	681970
			300	730025
			350	730033
			400	730041
			500	692328
			600	730068
			800	692336
			1000	730076
			1200	730084
			40,0	187,5
250	730092			
300	730106			
350	730114			
400	730122			
500	692344			
600	730130			
800	692352			
1000	730149			
1200	730157			

Maßangaben in mm / Änderungen vorbehalten · Dimensions in mm / We reserve the right to make modifications · Dimensions en mm / Sous réserve de changements
08/04

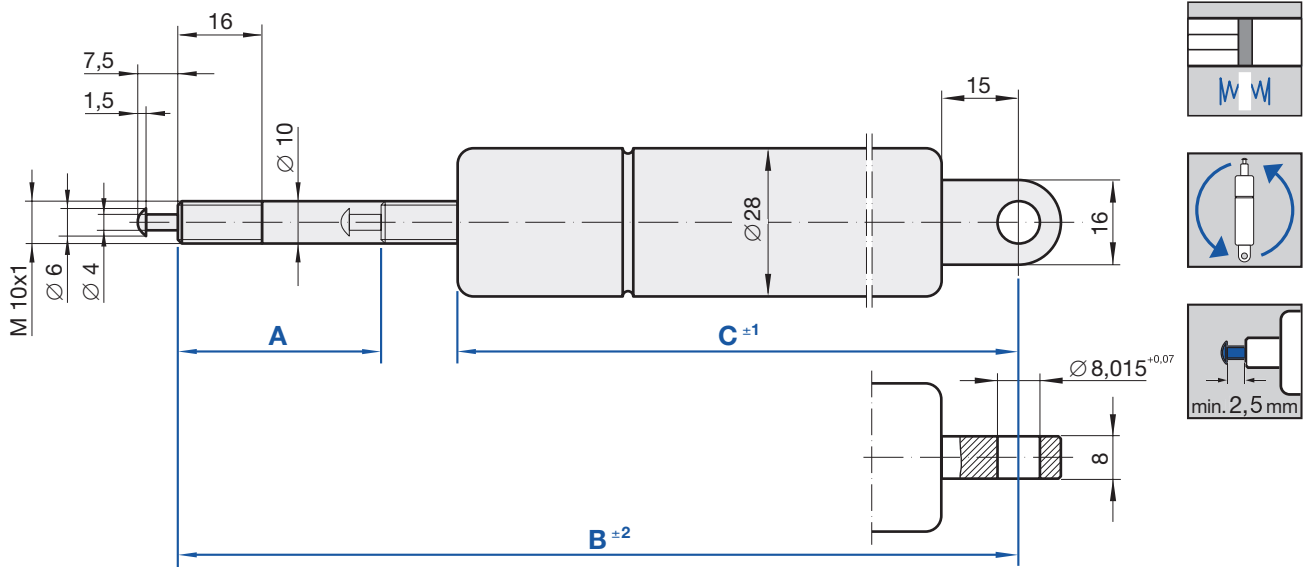

A Hub Stroke Course	B Ausgesch. Länge Extended length Longueur sortie	C Druckrohrlänge Length of pressure tube Longueur du tube de pression	F ₁ - [N]	Bestell-Nr. Ref.-No. Réf.-No.
60,0	228,0	151,5	200	681865
			250	729345
			300	729353
			350	729361
			400	729388
			500	691933
			600	729396
			800	691941
			1000	729418
			1200	729426
80,0	269,0	171,5	200	681946
			250	729434
			300	729442
			350	729450
			400	729469
			500	691968
			600	729477
			800	691976
100,0	310,0	191,5	200	681873
			250	729507
			300	729515
			350	729523
			400	729531
			500	691984
			600	729558
			800	691992
			1000	729566
			1200	729574
120,0	348,0	211,5	200	681881
			250	729582
			300	729590
			350	729604
			400	729612

A Hub Stroke Course	B Ausgesch. Länge Extended length Longueur sortie	C Druckrohrlänge Length of pressure tube Longueur du tube de pression	F ₁ - [N]	Bestell-Nr. Ref.-No. Réf.-No.
120,0	348,0	211,5	500	692018
			600	729620
			800	692026
			1000	729639
			1200	729647
160,0	430,0	251,5	200	681903
			250	729655
			300	729663
			350	729671
			400	729698
			500	692034
			600	729701
			800	692212
200,0	509,0	291,5	1000	729728
			1200	729736
			200	681911
			250	729744
			300	729752
			350	729760
			400	729779
			500	692220
250,0	610,0	341,5	600	729787
			800	692239
			1000	729795
			1200	729809
			200	681938
			250	729817
			300	729825
			350	729833
			400	729841
			500	692247
600	729868			
800	692255			
1000	729876			
1200	729884			

Maßangaben in mm / Änderungen vorbehalten · Dimensions in mm / We reserve the right to make modifications · Dimensions en mm / Sous réserve de changements 08/04

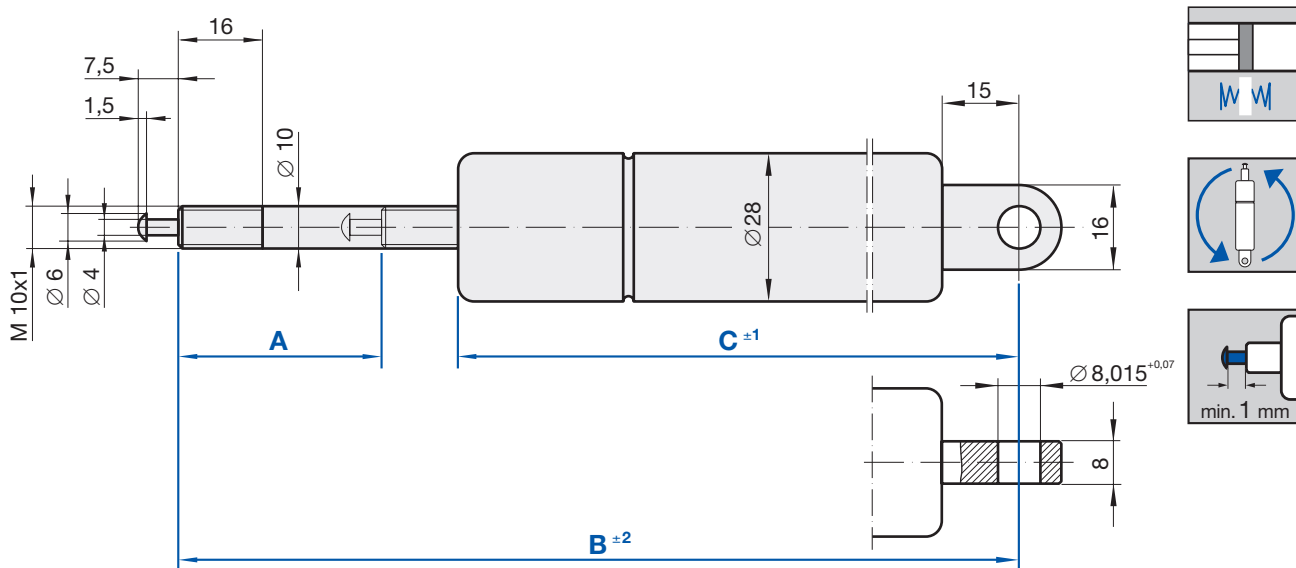

A	B	C	F ₁ - [N]	Bestell-Nr. Ref.-No.
Hub Stroke Course	Ausgesch. Länge Extended length Longueur sortie	Druckrohrlänge Length of pressure tube Longueur du tube de pression		Réf.-No.
60,0	228,0	151,5	200	692360
			250	730165
			300	730173
			350	730181
			400	730203
			500	682136
			600	730211
			800	692379
			1000	730238
			1200	730246
100,0	310,0	191,5	200	682144
			250	730254
			300	730262
			350	730270
			400	730289
			500	692387
			600	730297
			800	692395
			1000	730300
			1200	730319
200,0	509,0	291,5	200	682152
			250	730327
			300	730335
			350	730343
			400	730351
			500	692409
			600	730378
			800	692417
			1000	730386
			1200	730394

Maßangaben in mm / Änderungen vorbehalten · Dimensions in mm / We reserve the right to make modifications · Dimensions en mm / Sous réserve de changements
08/04

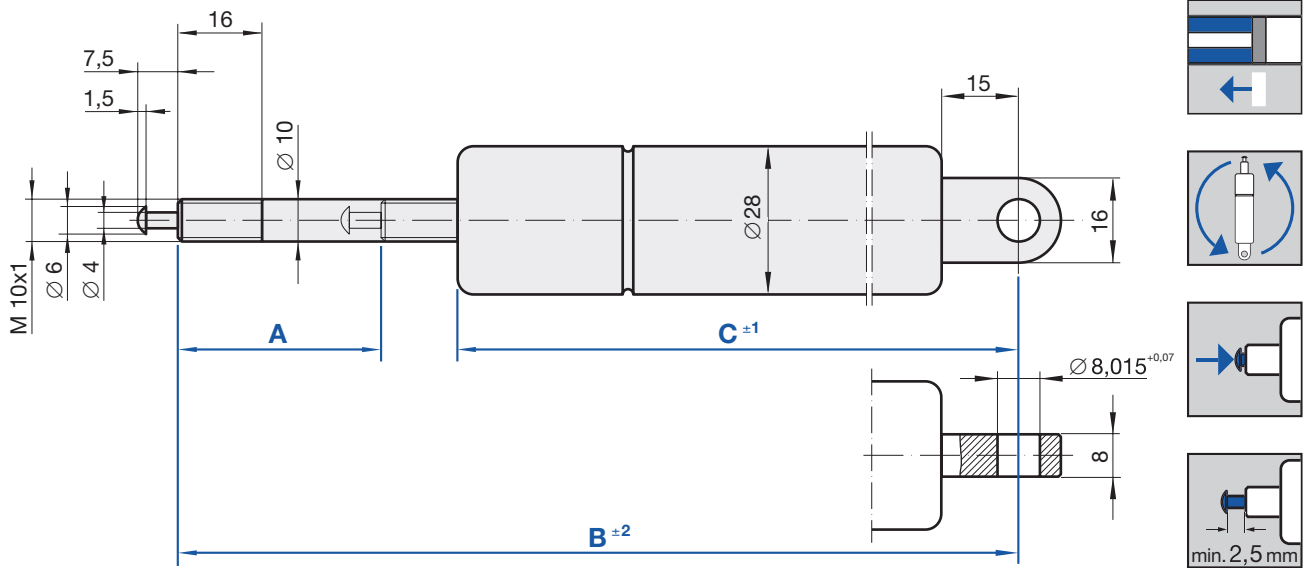

A Hub Stroke Course	B Ausgesch. Länge Extended length Longueur sortie	C Druckrohrlänge Length of pressure tube Longueur du tube de pression	FZ [N]	FD [N]	F ₁ - [N]	Bestell-Nr. Ref.-No. Réf.-No.
19,5	164,5	127,0	9500	2000	400	2691HR
			8500	2500	500	2694HC
			7500	3000	600	2696HT
			5500	4000	800	2698HJ
			3500	5000	1000	2721HZ
			2000	6000	1200	2723HP
25,5	177,5	134,0	9000	2000	400	2727HW
			8000	2500	500	2731HT
			7000	3000	600	2733HJ
			5500	4000	800	2736HV
			3000	5000	1000	2738HL
			1000	6000	1200	2741HN
31,5	192,5	143,0	10000	1000	300	2745HU
			9000	2000	400	2748HF
			8000	2500	500	2751HH
			7000	3000	600	2753HY
			5000	4000	800	2611HL
			3000	5000	1000	2776HY
40,5	212,5	154,0	10000	1000	300	2787HN
			9000	2000	400	2791HK
			8000	2500	500	2793HA
			7000	3000	600	2803HU
			5000	4000	800	2805HK
			2500	5000	1000	2807HA

FZ = Blockierkraft in Zugrichtung (N)
Blocking force in traction direction (N)
Force de blocage en traction (N)

FD = Blockierkraft in Druckrichtung (N)
Blocking force in compression direction (N)
Force de blocage en compression (N)

Maßangaben in mm / Änderungen vorbehalten · Dimensions in mm / We reserve the right to make modifications · Dimensions en mm / Sous réserve de changements
08/04

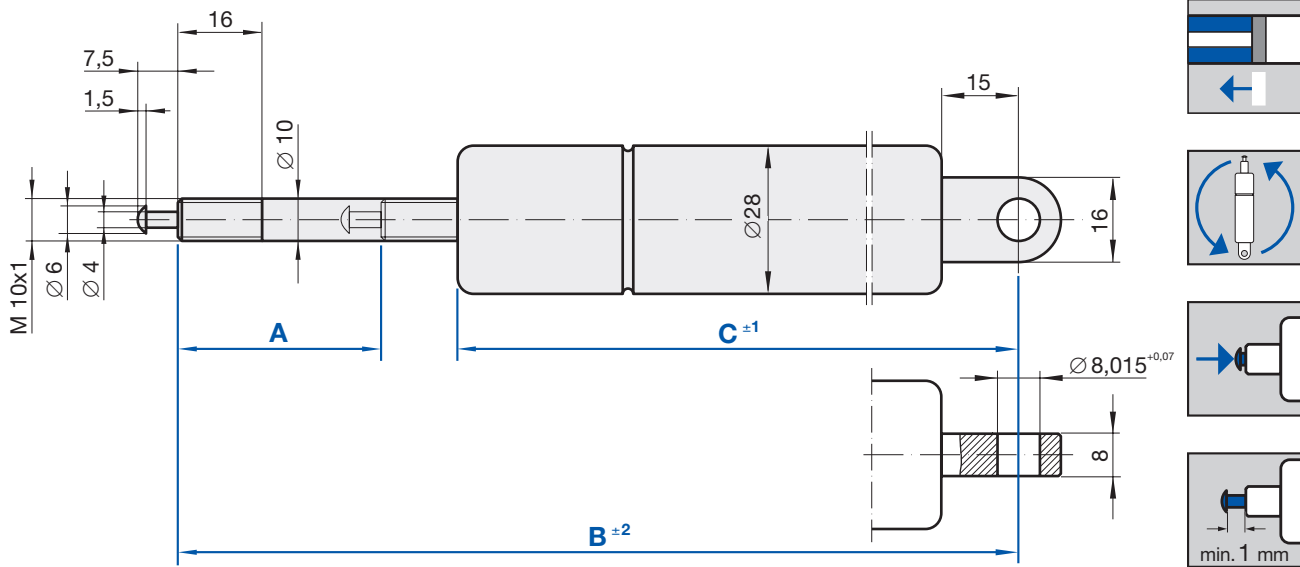

A Hub Stroke Course	B Ausgesch. Länge Extended length Longueur sortie	C Druckrohrlänge Length of pressure tube Longueur du tube de pression	FZ [N]	FD [N]	F ₁ - [N]	Bestell-Nr. Ref.-No. Réf.-No.
19,5	164,5	127,0	4500	2000	400	5139HY
			5500	2500	500	5144HQ
			7000	3000	600	5146HG
			6000	4000	800	5148HX
			4000	5000	1000	5151HZ
			2000	6000	1200	5153HP
25,5	177,5	134,0	4500	2000	400	5157HW
			6000	2500	500	5169HG
			7000	3000	600	5172HI
			5500	4000	800	5174HZ
			3500	5000	1000	5176HP
			1500	6000	1200	5178HF
31,5	192,5	143,0	3500	1000	300	5183HY
			5000	2000	400	5186HJ
			6000	2500	500	5189HV
			7000	3000	600	5192HX
			5500	4000	800	5194HN
			3500	5000	1000	5196HD
			1500	6000	1200	5198HU
40,5	212,5	154,0	4000	1000	300	5203HL
			5000	2000	400	5206HX
			6500	2500	500	5208HN
			7000	3000	600	5211HP
			5000	4000	800	5213HF
			3000	5000	1000	5215HW

FZ = Blockierkraft in Zugrichtung (N)
Blocking force in traction direction (N)
Force de blocage en traction (N)

FD = Blockierkraft in Druckrichtung (N)
Blocking force in compression direction (N)
Force de blocage en compression (N)

Maßangaben in mm / Änderungen vorbehalten · Dimensions in mm / We reserve the right to make modifications · Dimensions en mm / Sous réserve de changements
08/04

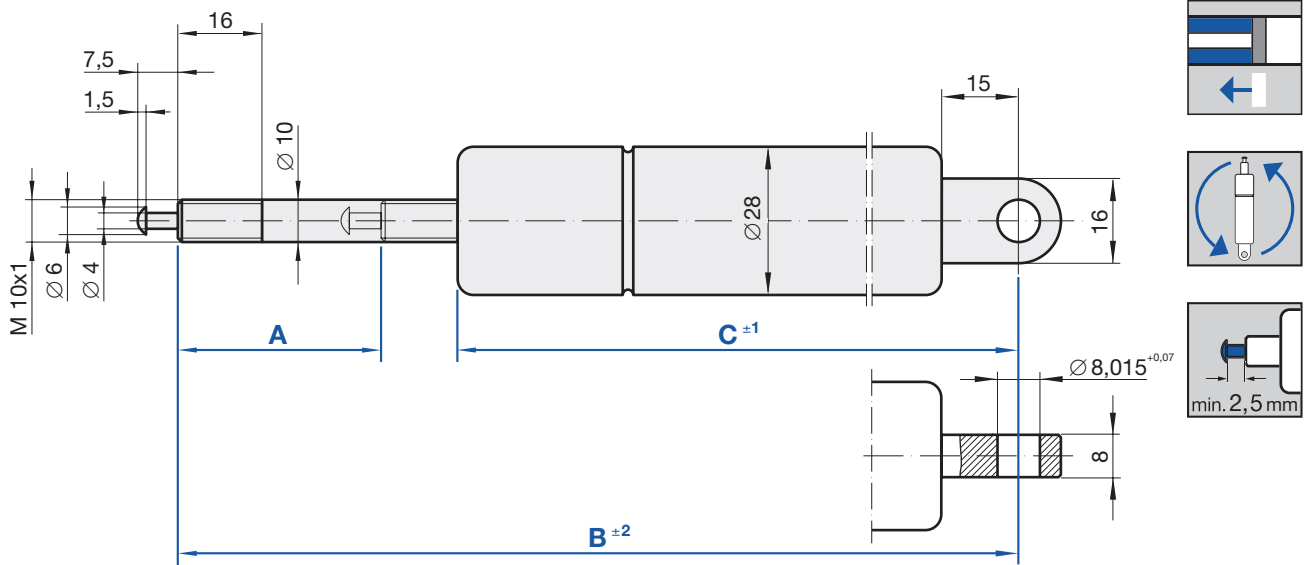

A	B	C	FZ [N]	FD [N]	F ₁ - [N]	Bestell-Nr.
Hub Stroke Course	Ausgesch. Länge Extended length Longueur sortie	Druckrohr- länge Length of pressure tube Longueur du tube de pression				Ref.-No. Réf.-No.
60,0	265,0	187,0	10000	1000	300	5219HC
			9000	2000	400	5224HV
			8000	2500	500	5226HL
			7000	3000	600	5228HB
			4500	4000	800	5231HD
			2500	5000	1000	5233HU
81,0	310,0	211,0	10500	900	200	2784HB
			9500	1000	300	5238HW
			8500	2000	400	5241HY
			7500	2500	500	5243HO
			6500	3000	600	5245HE
			4000	4000	800	5248HQ
			1500	5000	1000	5251HS
			100,5	370,5	252,0	10500
9500	1000	300	5258HK			
8500	2000	400	5261HM			
7000	2500	500	5263HC			
6000	3000	600	5265HT			
3500	4000	800	5267HJ			

A	B	C	FZ [N]	FD [N]	F ₁ - [N]	Bestell-Nr.
Hub Stroke Course	Ausgesch. Länge Extended length Longueur sortie	Druckrohr- länge Length of pressure tube Longueur du tube de pression				Ref.-No. Réf.-No.
121,5	420,5	281,0	10500	900	200	5273HX
			9500	1000	300	5281HA
			8000	2000	400	5283HR
			7000	2500	500	5285HH
			6000	3000	600	5287HY
			3500	4000	800	5289HO
			160,5	510,5	332,0	10500
9000	1000	300	5297HS			
8000	2000	400	5299HI			
7000	2500	500	5302HJ			
5500	3000	600	5311HI			
3000	4000	800	5313HZ			
199,5	600,5	383,0	10500			900
			9000	1000	300	5321HC
			8000	2000	400	5323HT
			6500	2500	500	5325HJ
			5500	3000	600	5328HV
			2500	4000	800	5331HX

FZ = Blockierkraft in Zugrichtung (N)
Blocking force in traction direction (N)
Force de blocage en traction (N)

FD = Blockierkraft in Druckrichtung (N)
Blocking force in compression direction (N)
Force de blocage en compression (N)

Maßangaben in mm / Änderungen vorbehalten · Dimensions in mm / We reserve the right to make modifications · Dimensions en mm / Sous réserve de changements 08/04

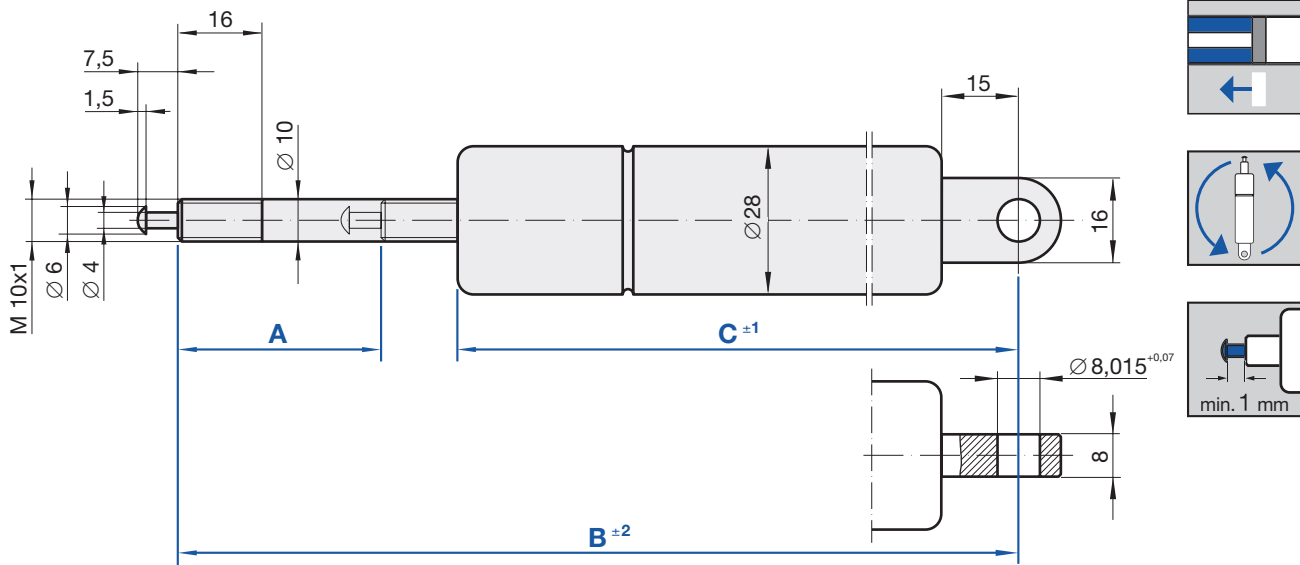

A Hub Stroke Course	B Ausgesch. Länge Extended length Longueur sortie	C Druckrohrlänge Length of pressure tube Longueur du tube de pression	FZ [N]	FD [N]	F ₁ - [N]	Bestell-Nr. Ref.-No. Réf.-No.
60,0	265,0	187,0	2500	900	200	5352HG
			4000	1000	300	5355HS
			5000	2000	400	5357HI
			6500	2500	500	5359HZ
			7000	3000	600	5362HA
			5000	4000	800	5364HR
			2500	5000	1000	5366HH
100,5	370,5	252,0	3000	900	200	5372HV
			4500	1000	300	5375HG
			6000	2000	400	5377HX
			7000	2500	500	5379HN
			6000	3000	600	5382HP
			4000	4000	800	5384HF
160,5	510,5	332,0	3000	900	200	5388HM
			4500	1000	300	5392HJ
			6000	2000	400	5395HV
			7000	2500	500	5397HL
			6000	3000	600	5399HB
			3000	4000	800	5402HC
			3000	900	200	5406HJ
250,5	730,5	462,0	4500	1000	300	5411HB
			6000	2000	400	5413HS
			7000	2500	500	5415HI
			6000	3000	600	5417HZ
			3000	4000	800	5419HP

FZ = Blockierkraft in Zugrichtung (N)
Blocking force in traction direction (N)
Force de blocage en traction (N)

FD = Blockierkraft in Druckrichtung (N)
Blocking force in compression direction (N)
Force de blocage en compression (N)

Maßangaben in mm / Änderungen vorbehalten · Dimensions in mm / We reserve the right to make modifications · Dimensions en mm / Sous réserve de changements
08/04

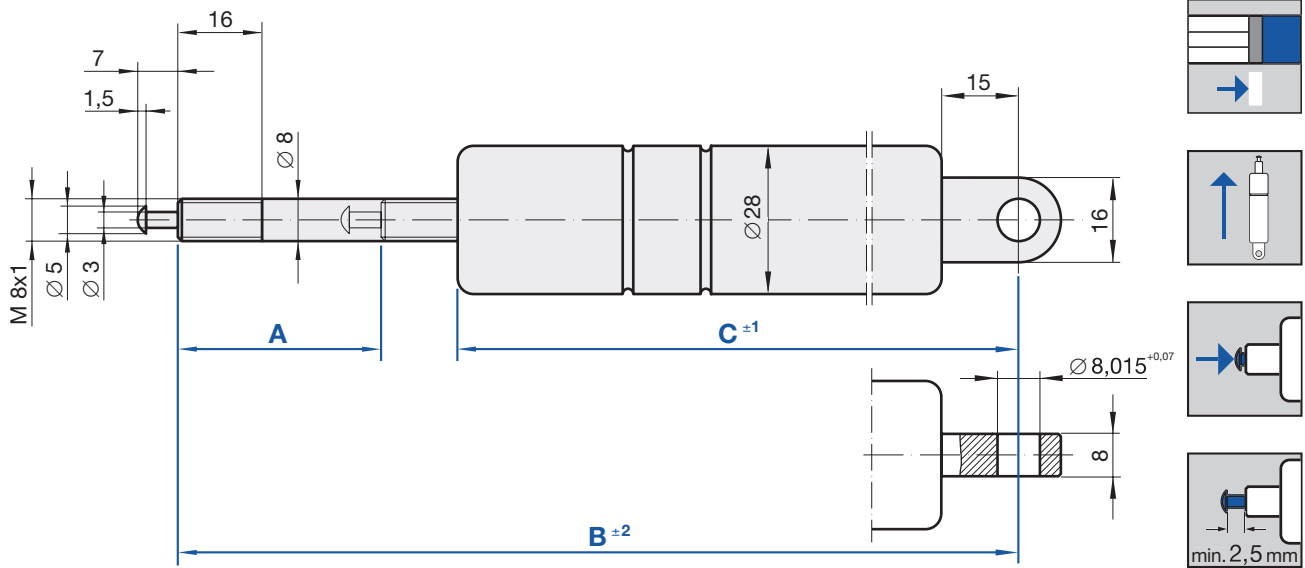

A Hub Stroke Course	B Ausgesch. Länge Extended length Longueur sortie	C Druckrohr- länge Length of pressure tube Longueur du tube de pression	FZ [N]	FD [N]	F ₁ - [N]	Bestell-Nr. Ref.-No. Réf.-No.
20,0	179,0	141,0	1000	13000	200	684058
			1500	12500	250	733199
			2000	12000	300	733202
			2500	11500	350	733210
			3000	10500	400	733229
			4000	9500	500	670138
			5000	8000	600	733237
			4000	5500	800	693391
			1000	3000	1000	733245
25,0	190,0	147,0	1000	13000	200	684066
			1500	12500	250	733253
			2000	12000	300	733261
			2500	11500	350	733288
			3000	10500	400	733296
			4000	9500	500	693405
			5000	8000	600	733318
			3500	5500	800	693413
			500	2500	1000	733326

A Hub Stroke Course	B Ausgesch. Länge Extended length Longueur sortie	C Druckrohr- länge Length of pressure tube Longueur du tube de pression	FZ [N]	FD [N]	F ₁ - [N]	Bestell-Nr. Ref.-No. Réf.-No.
30,0	204,0	156,0	1000	13000	200	684074
			1500	12500	250	733334
			2000	12000	300	733342
			2500	11500	350	733350
			3000	10500	400	733369
			4000	9000	500	693421
			5000	8000	600	733377
			3500	5000	800	693448
			500	2500	1000	733385
40,0	226,0	170,0	1000	13000	200	684082
			1500	12500	250	733393
			2000	12000	300	733407
			2500	11000	350	733415
			3000	10500	400	733423
			4000	9000	500	693456
			5000	8000	600	733431
			3000	5000	800	693464

FZ = Blockierkraft in Zugrichtung (N)
Blocking force in traction direction (N)
Force de blocage en traction (N)

FD = Blockierkraft in Druckrichtung (N)
Blocking force in compression direction (N)
Force de blocage en compression (N)

Maßangaben in mm / Änderungen vorbehalten · Dimensions in mm / We reserve the right to make modifications · Dimensions en mm / Sous réserve de changements 08/04

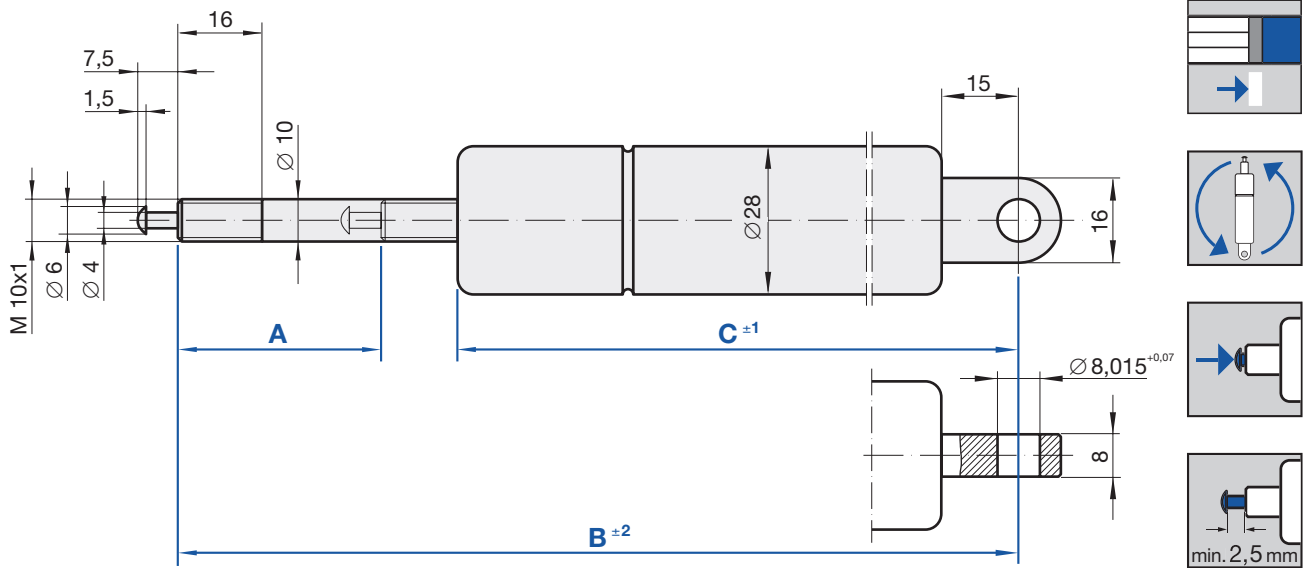

A Hub Stroke Course	B Ausgesch. Länge Extended length Longueur sortie	C Druckrohr- länge Length of pressure tube Longueur du tube de pression	FZ [N]	FD [N]	F ₁ - [N]	Bestell-Nr. Ref.-No. Réf.-No.
20,0	191,5	153,5	2500	12000	500	670669
			3000	11000	600	682756
			4000	9000	800	693278
			5000	8000	1000	732869
			3500	6500	1200	732877
25,0	205,5	163,5	2000	12500	400	682764
			2500	12000	500	693286
			3000	11000	600	732885
			4000	9500	800	693294
			5000	8000	1000	732893
30,0	219,5	173,5	3500	6500	1200	767689
			1500	13000	350	682772
			2000	12500	400	732907
			2500	11500	500	693308
			3000	10500	600	732915
40,0	241,5	184,5	4000	9000	800	693316
			4500	7000	1000	732923
			2500	5500	1200	732931
			1500	12500	350	682799
			2000	12000	400	732958
			2500	11000	500	693324
			3000	10000	600	732966
			4000	8500	800	693332
			3500	6500	1000	732974

A Hub Stroke Course	B Ausgesch. Länge Extended length Longueur sortie	C Druckrohr- länge Length of pressure tube Longueur du tube de pression	FZ [N]	FD [N]	F ₁ - [N]	Bestell-Nr. Ref.-No. Réf.-No.
80,0	350,5	253,5	500	13500	200	682802
			1000	13500	250	732982
			1000	13000	300	732990
			1500	12500	350	733008
			2000	12000	400	733016
			2500	11000	500	670677
			3000	10000	600	733024
100,0	400,5	284,5	4000	8000	800	693340
			3000	6000	1000	733032
			500	13500	200	682810
			1000	13000	250	733040
			1000	12500	300	733059
			1500	12000	350	733067
			2000	12000	400	733075
120,0	450,5	313,5	2500	11000	500	693359
			3000	10000	600	733105
			4000	7500	800	693367
			2500	5500	1000	733113
			500	13500	200	684023
			1000	13000	250	733121
			1000	12500	300	733148
			1500	12000	350	733156
			2000	11500	400	733164
			2500	10500	500	693375
3000	9500	600	733172			
4000	7500	800	693383			
2000	5000	1000	733180			

FZ = Blockierkraft in Zugrichtung (N)
Blocking force in traction direction (N)
Force de blocage en traction (N)

FD = Blockierkraft in Druckrichtung (N)
Blocking force in compression direction (N)
Force de blocage en compression (N)

Maßangaben in mm / Änderungen vorbehalten · Dimensions in mm / We reserve the right to make modifications · Dimensions en mm / Sous réserve de changements 08/04

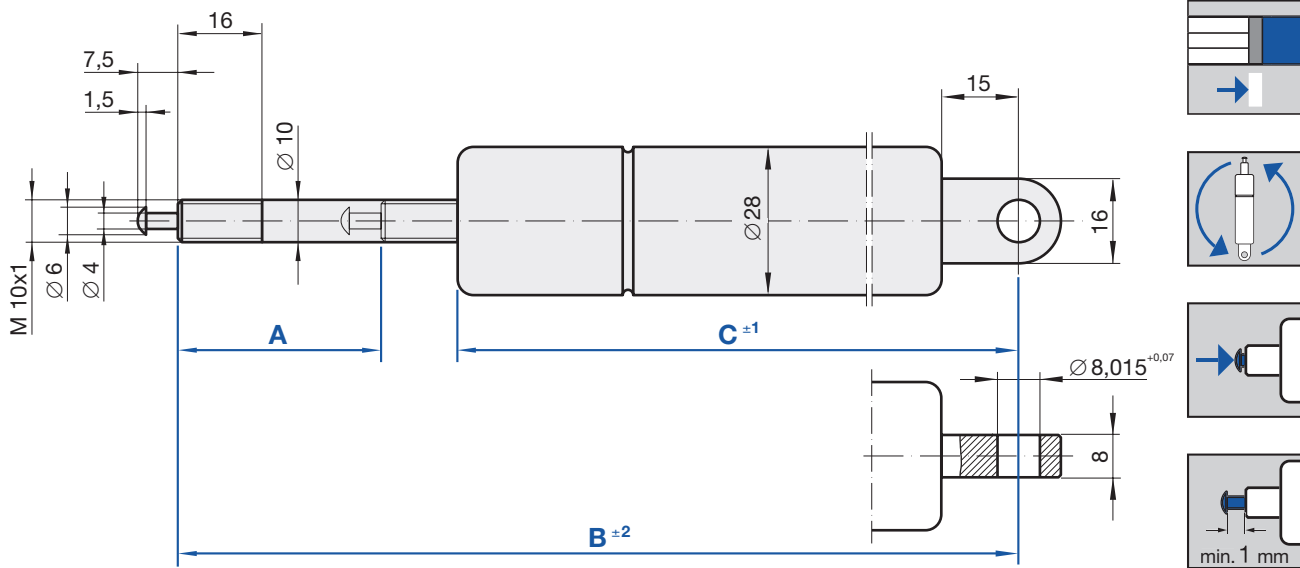

A Hub Stroke Course	B Ausgesch. Länge Extended length Longueur sortie	C Druckrohrlänge Length of pressure tube Longueur du tube de pression	FZ [N]	FD [N]	F ₁ - [N]	Bestell-Nr. Ref.-No. Réf.-No.
20,0	191,0	154,5	2500	12000	500	693189
			3000	11000	600	682705
			4000	9500	800	693197
			5000	8000	1000	732737
			3500	6000	1200	732745
25,0	205,0	161,5	2000	12500	400	682713
			2500	11500	500	693200
			3000	11000	600	732753
			4000	9500	800	693219
			4500	7500	1000	732761
			3000	5500	1200	827851
30,0	219,0	172,5	1500	13000	350	682721
			2000	12500	400	732788
			2500	11500	500	693227
			3000	11000	600	732796
			4000	9000	800	693235
			4500	7500	1000	732818
			3000	6500	1200	732826
40,0	241,0	184,5	1500	12500	350	682748
			2000	12000	400	732834
			2500	11500	500	693243
			3000	10500	600	732842
			4000	8500	800	693251
			4000	6500	1000	732850

FZ = Blockierkraft in Zugrichtung (N)
 Blocking force in traction direction (N)
 Force de blocage en traction (N)

FD = Blockierkraft in Druckrichtung (N)
 Blocking force in compression direction (N)
 Force de blocage en compression (N)

Maßangaben in mm / Änderungen vorbehalten · Dimensions in mm / We reserve the right to make modifications · Dimensions en mm / Sous réserve de changements
 08/04

Zubehör
Accessories
Accessoires

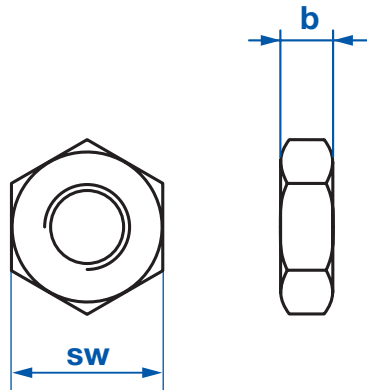

Muttern / Screw nuts / Ecrou

Gewinde Thread Filet	b	sw	Bestell-Nr. Ref.-No. Réf.-No.
M 8x1	5	13	012483
M 10x1	6	17	012491

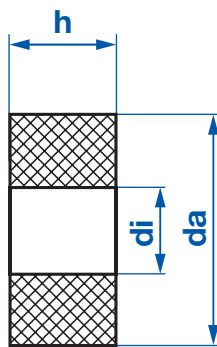

**Gummipuffer / Rubber bumper /
Rondelle à caoutchouc**

di Innen-ø Inner diameter Calibre	da	h	Bestell-Nr. Ref.-No. Réf.-No.
ø 8	20	8	269069
ø 10	20	4	036862
		8	036854

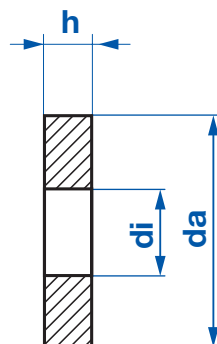

Scheibe / Washer / Rondelle

di Innen-ø Inner diameter Calibre	da	h	Bestell-Nr. Ref.-No. Réf.-No.
ø 8	19	3	023582
ø 10	24	3	363979

Maßangaben in mm / Änderungen vorbehalten · Dimensions in mm / We reserve the right to make modifications · Dimensions en mm / Sous réserve de changements
08/04

Zubehör
Accessories
Accessoires

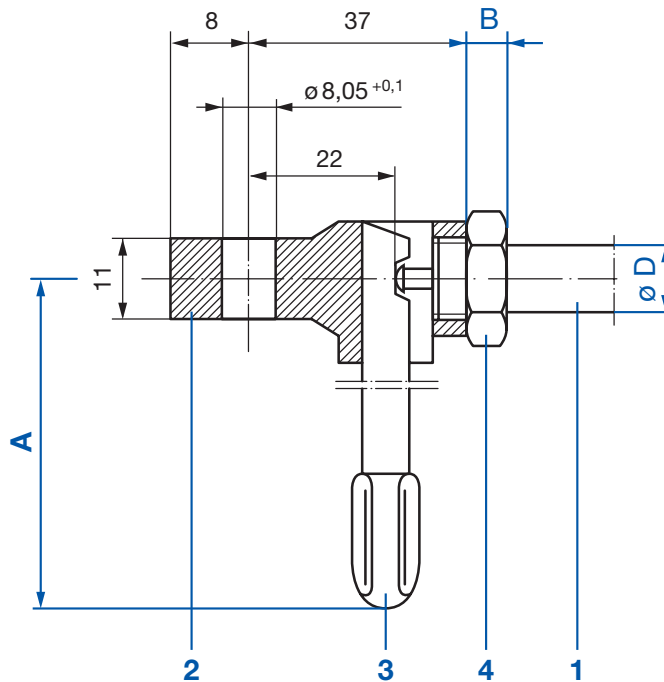

1	ø D	ø 8	ø 10
	Gewinde / Thread / Filet	M 8 x 1	M 10 x 1
	Auslöseweg / Release way / course de déclenchement	1 mm	1 mm
	B	5 mm	6 mm
2	Auslösekopf Standard Release head for standard release Tête de déclenchement avec levier	9102GW	130850
	Auslösekopf für Dauerauslösung Release head for permanent release Tête de déclenchement avec levier pour déclenchement permanent	0516CC	271985
3	A	64 mm	992259
	Auslösehebel Release lever Levier de déclenchement	104 mm	1041BN
		122 mm	132543
		167 mm	065056
		196 mm	125466
4	Sechskantmutter / Screw nuts / Ecrou	012483	012491

Auslösekopf geeignet für alle BLOC-O-LIFT aus unserem Standardprogramm mit Auslöseweg 1 mm. Bitte beachten Sie die Montageanleitung für BLOC-O-LIFT Auslösekopf

STAB-Spec. 1000 5725

Release head suitable for all BLOC-O-LIFT from our standard programme with release way 1 mm. Please pay attention to the mounting instructions for the BLOC-O-LIFT release head

STAB-Spec. 1000 5725

Tête de déclenchement convenable à tous les BLOC-O-LIFT de notre programme standard avec course de déclenchement 1 mm. Faites attention aux instructions de montage des têtes de déclenchement BLOC-O-LIFT

STAB-Spec. 1000 5725

Zubehör
Accessories
Accessoires

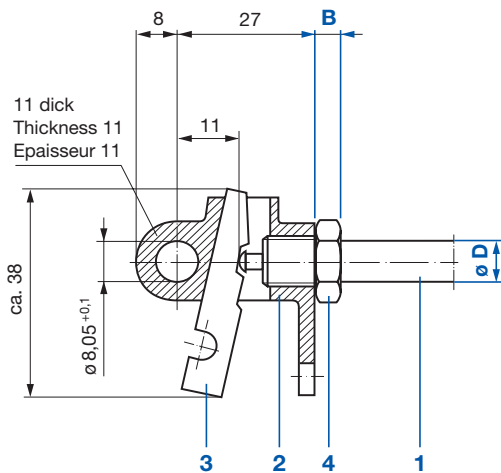

1	ø D	ø 8	ø 10
	Gewinde / Thread / Filet	M 8 x 1	M 10 x 1
	B	5 mm	6 mm
2	Auslösekopf Release head Tête de déclenchement	983918	784575
3	Auslösehebel Release lever Lever de déclenchement	783234	
4	Sechskantmutter / Screw nuts / Ecrou	012483	012491

Auslösekopf geeignet für alle BLOC-O-LIFT aus unserem Standardprogramm. Bitte beachten Sie die Montageanleitung für BLOC-O-LIFT Auslösekopf
STAB-Spec. 1000 6476 und STAB-Spec. 1000 5635

Release head suitable for all BLOC-O-LIFT from our standard programme. Please pay attention to the mounting instructions for the BLOC-O-LIFT release head
STAB-Spec. 1000 6476 and STAB-Spec. 1000 5635

Tête de déclenchement convenable à tous les BLOC-O-LIFT de notre programme standard. Faites attention aux instructions de montage des têtes de déclenchement BLOC-O-LIFT
STAB-Spec. 1000 6476 et STAB-Spec. 1000 5635

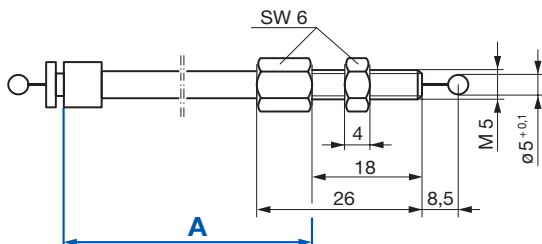

A	Bowdenzuglänge Length of bowden-wire Longueur du câble bowden	Bestell-Nr. Ref.-No. Réf.-No.
	200	0345BH
	300	878189
	400	7605AV
	500	0346BC
	600	0347BY
	700	5240AD
	800	0304BJ
	900	0298BX
	1000	0305BE

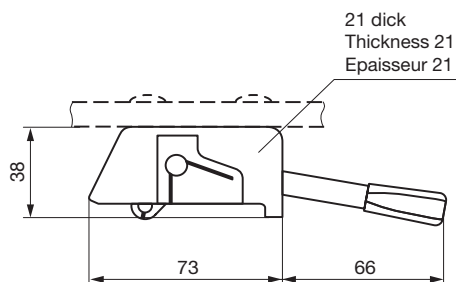

	Auslöseeinheit Release unit Mécanisme de déclenchement	Bestell-Nr. Ref.-No. Réf.-No.
		1044BZ











Für eine Auslöseeinheit mit einem Bowdenzug länger als 400 mm ist ein BLOC-O-LIFT mit Auslöseweg 1 mm erforderlich.
For a release unit with a bowden-wire longer than 400 mm a BLOC-O-LIFT with release way 1 mm is necessary.
Pour un mécanisme de déclenchement avec un câble bowden plus long que 400 mm un BLOC-O-LIFT avec course de déclenchement 1 mm est nécessaire.

Maßangaben in mm / Änderungen vorbehalten · Dimensions in mm / We reserve the right to make modifications · Dimensions en mm / Sous réserve de changements
08/04

Notizen / Notes / Notes

A large grid of graph paper for taking notes, consisting of 20 columns and 30 rows of small squares.

INDEX

STAB-O-MAT	STAB-O-BLOC											Seite Page Page
<input type="checkbox"/>		<input type="checkbox"/>										54
<input type="checkbox"/>			<input type="checkbox"/>									55
	<input type="checkbox"/>	<input type="checkbox"/>										56
	<input type="checkbox"/>		<input type="checkbox"/>									57
<input type="checkbox"/>						<input type="checkbox"/>						58
<input type="checkbox"/>		<input type="checkbox"/>					<input type="checkbox"/>					59
<input type="checkbox"/>			<input type="checkbox"/>				<input type="checkbox"/>					60
<input type="checkbox"/>					<input type="checkbox"/>							61
	<input type="checkbox"/>			<input type="checkbox"/>								62
<input type="checkbox"/>			<input type="checkbox"/>					<input type="checkbox"/>				63
<input type="checkbox"/>			<input type="checkbox"/>						<input type="checkbox"/>			64
	<input type="checkbox"/>		<input type="checkbox"/>							<input type="checkbox"/>		65
	<input type="checkbox"/>		<input type="checkbox"/>								<input type="checkbox"/>	66





Zubehör 67

Accessories Page 67

Accessories Page 67

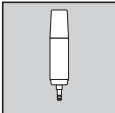
STAB-O-MAT[®] STAB-O-BLOC[®]

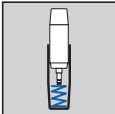
Stufenlose Höhenverstellung von Drehstühlen
Stepless height adjustment of swivel chairs
Réglage progressif en hauteur des chaises pivotantes

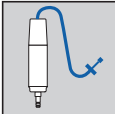
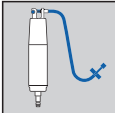
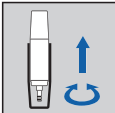
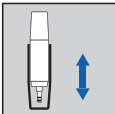
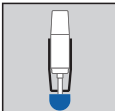
Ohne Standrohr Without outer-tube Sans fût	
Säule Column Colonne	
Komfortable Einfederung Comfortable spring deflection Suspension grand confort	
Mechanische Tiefenfederung Mechanical depth cushioning Amortissement mécanique en position basse	
Teleskop-Standrohr Telescope stand tube Colonne à fût télescopique	
Axiale Bowdenzugauslösung Axial Cable Release Déclenchement axiale câble bowden	
Radiale Bowdenzugauslösung Radial cable release Déclenchement latérale par câble bowden	
Multifunktionssäule Multi-Function Column Colonne multi-fonction	
Verdrehsichere Säule Swivel Resistant Column Colonne bloquée en rotation	
Zusätzliche Stoppfunktion Additional Stop-Function Fonction de stop supplémentaire	

Notizen / Notes / Notes

A large grid of graph paper for taking notes, consisting of 20 columns and 30 rows of small squares.

Technische Informationen
Technical information
Information technique

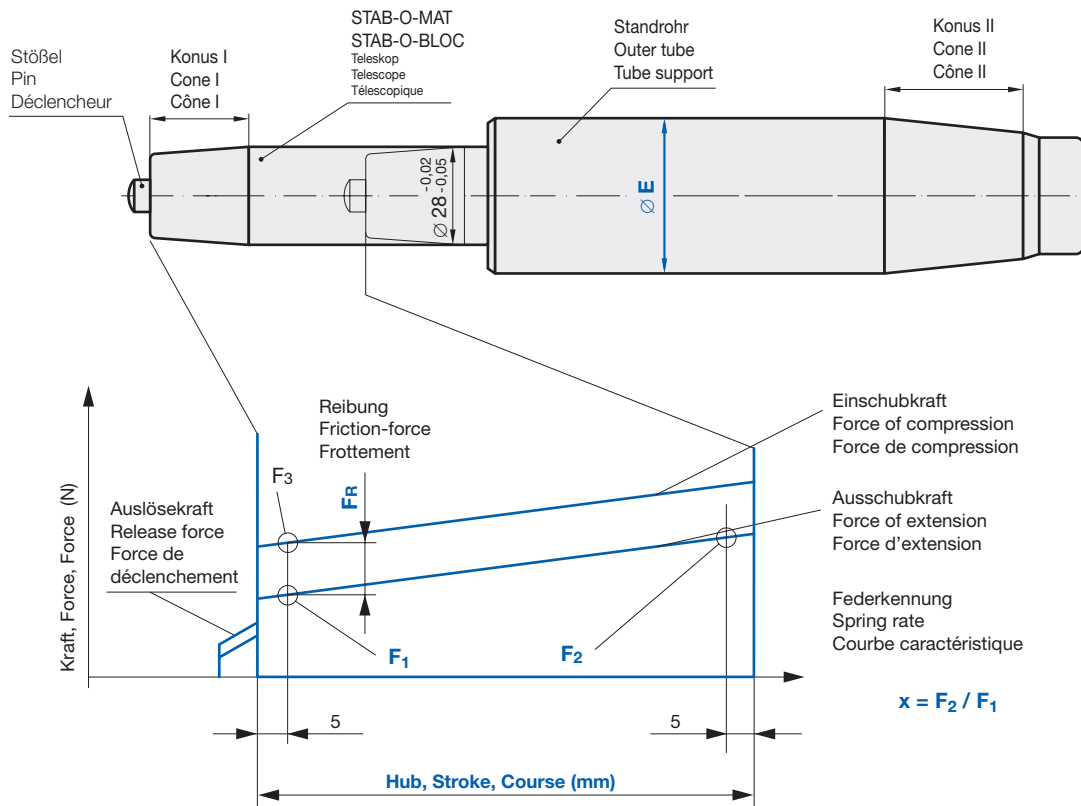

∅ E (mm)	Ausschubkraft Force of extension Force d'extension F ₁ (N)		X (≈)	F _R max. (N)	Auslösekraft Release force Force de déclenchement
	min.	max.			
40	200	500	1,2	100	ca. 30 % F ₁
45	200	500	1,2	100	ca. 30% F ₁
50	200	500	1,2	100	ca. 30% F ₁

Einbauvorschrift
Installation instruction
Instruction de montage **STAB-Spec. 1000 5593**

Ventilauslösekraft nach
Release force of calve according
Force d'ouverture de la soupape selon **STAB-Spec. 1000 5233**

Statische Messung der Kräfte
Statically measured forces
Forces mesurées statiquement **STAB-Spec. 1000 9033**

Konus-Festigkeitsgruppe DIN 4550-2
Cone-Range of strength
Cône-Plage de résistance **STAB-Spec. 1000 5493**

Entsorgungsvorschrift
Disposal instruction
Instruction de neutralisation **STAB-Spec. 1000 9375**
www.stabilus.com/recycling

Auslöseweg Release way Course de déclenchement	
STAB-O-MAT®	min. 2,5 mm
STAB-O-BLOC®	min. 1,7 mm

STAB-O-MAT®
Selbsttragende Gasfeder
Self-supporting gas spring
Ressort à gaz auto-portant

STAB-O-BLOC®
Nicht selbsttragende Gasfeder
Non-self supporting gas spring
Ressort à gaz non auto-portant

Stößel mit Bohrung für Einstellschraube
Release pin suitable for use adjustable screw
Bouton de réglage avec perçage pour vis réglage

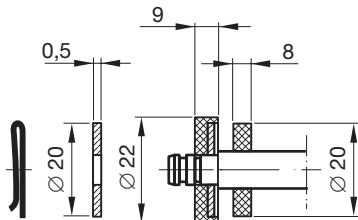
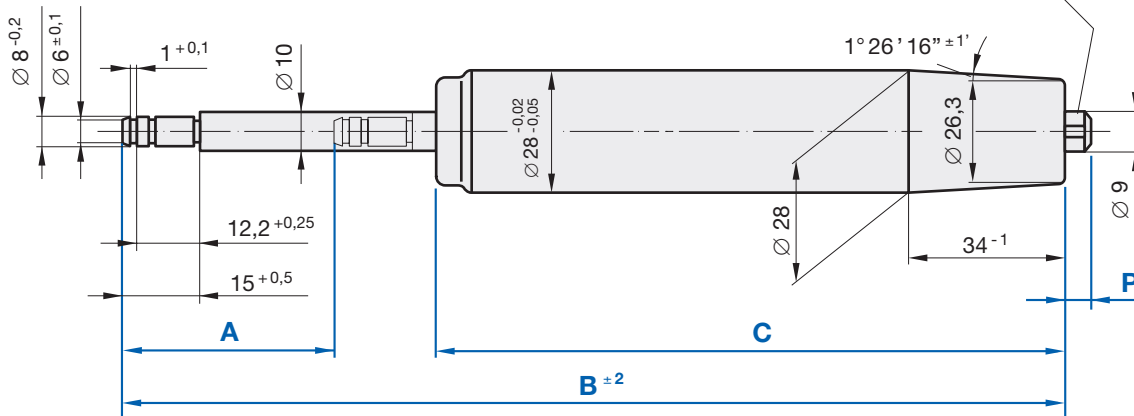
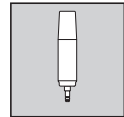

Axiallager Axial bearing set Butée à billes	Bestell-Nr. Ref.-No. Réf.-No.
7052LW	

A Hub Stroke Course	B Ausgesch. Länge Extended length Longueur sortie	C Druckrohrlänge Length of pressure tube Longueur du tube de pression	P Stößelüberstand Release pin projection Dépassement du poussoir	F ₁ - [N]	Bestell-Nr. Ref.-No. Réf.-No.
75,5	304,5	207	6,5	300	7874CH
				400	936413
90,5	337,5	225	6,5	400	8056GO
99,5	354,5	233	6,5	300	335916
				400	311677
111,5	364,5	231	6,5	300	603953
				400	9063CE
120,5	396,5	254	6,5	300	311707
				400	541222
135,5	412,5	255	6,5	300	604003
				400	0951FR
135,5	439,5	282	6,5	300	936367
141,5	439,5	276	6,5	300	311731
159,5	480,5	299	6,5	300	311774
201,5	562,5	339	6,5	300	604054
264,5	694,5	408	6,5	300	604100

Maßangaben in mm / Änderungen vorbehalten · Dimensions in mm / We reserve the right to make modifications · Dimensions en mm / Sous réserve de changements
08/04

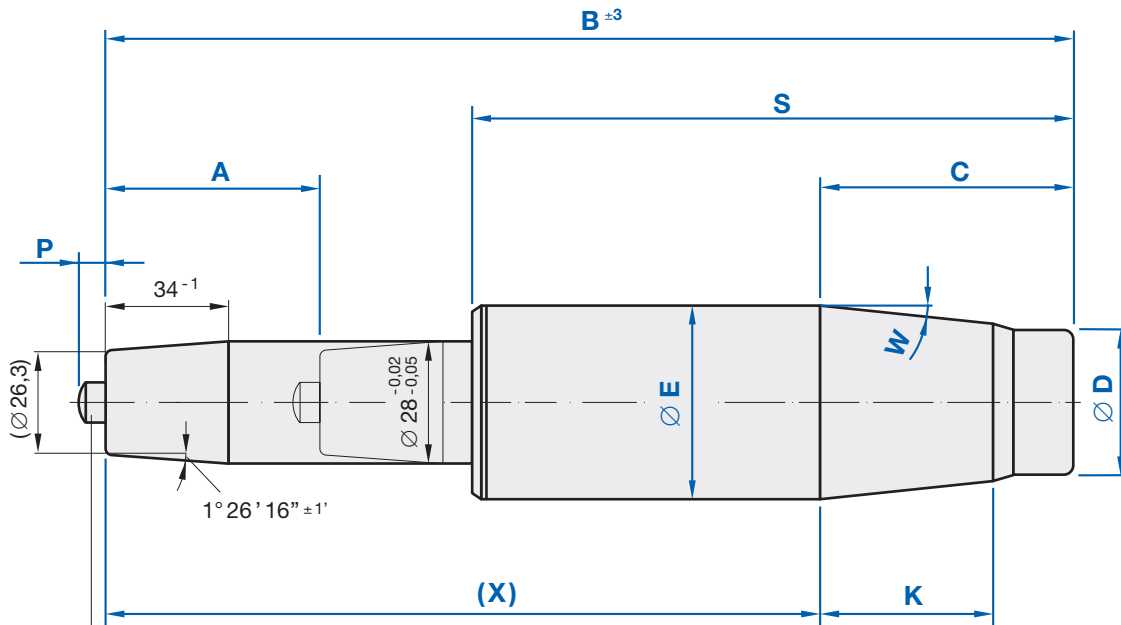

Stößel mit Bohrung für Einstellschraube
Release pin suitable for use adjustable screw
Bouton de réglage avec perçage pour vis réglage

ø E Standrohr- durchmesser Outer tube diameter Diamètre de colonne	A Hub Stroke Course	B Ausgesch. Länge Extended length Longueur sortie	X Fußkreuz- maß Dimension of chair base Dimensionne- ment piètement	C	ø D	S Standrohr- länge Length of support tube Longueur du tube de guidage	K Konus II Länge Cone II length Cône II longueur	W Konus II Winkel Cone II angle Cône II angle	P Stößel- überstand Release pin projection Dépassement du poussoir	F ₁ - [N]	Bestell-Nr. / Ref.-No. / Réf.-No. Standrohrfarbe Colour of support tube Couleur du tube de guidage	
											schwarz lackiert black paint finish laqué noir	matt verchromt dull chromed chromé mat
40	90,5	324,0	262,0	62	34,0	193,0	55	1°30'26"	6,5	400	604321	604518
	111,5	366,0	304,0	62	34,0	214,0	55	1°30'26"	6,5	300	604372	604550
	135,5	414,0	352,0	62	34,0	238,0	55	1°30'26"	6,5	300	604410	604593
	201,5	564,0	502,0	62	34,0	322,0	55	1°30'26"	6,5	300	604453	604631
	264,5	696,0	634,0	62	34,0	391,0	55	1°30'26"	6,5	300	605611	604682
45	90,5	320,5	233,5	87	38,5	190,0	65	1°30'26"	6,5	400	605662	604720
	111,5	362,5	275,5	87	38,5	211,0	65	1°30'26"	6,5	300	605700	604763
	135,5	410,5	323,5	87	38,5	235,0	65	1°30'26"	6,5	300	605743	604828
	201,5	560,5	473,5	87	38,5	319,0	65	1°30'26"	6,5	300	605794	604860
	264,5	692,5	605,5	87	38,5	388,0	65	1°30'26"	6,5	300	605832	604909
50	75,5	307,0	213,0	94	44,5	179,5	55	1°26'16"	6,5	400	7574GM	
	75,5	306,0	234,0	72	44,5	182,5	55	1°26'16"	6,5	400	3532FB	
	90,5	324,0	257,0	67	44,5	193,5	55	1°26'16"	6,5	400	605875	604941
	90,5	347,0	276,0	71	44,5	199,5	55	1°26'16"	6,5	400	8575EH	
	111,5	366,0	299,0	67	44,5	214,5	55	1°26'16"	6,5	300	605913	604992
	120,5	399,0	301,0	98	44,5	225,5	55	1°26'16"	6,5	300	9786HQ	
	135,5	416,0	323,0	93	44,5	239,5	45	1°26'16"	6,5	300	0989ER	
	120,5	399,0	328,0	71	44,5	223,5	55	1°26'16"	6,5	300	4426FN	
	124,5	442,0	347,0	95	44,5	258,5	78	1°26'16"	6,5	300	9764EX	
	135,5	414,0	347,0	67	44,5	238,5	55	1°26'16"	6,5	300	605964	605042
	129,5	421,0	350,0	71	44,5	234,5	55	1°26'16"	6,5	300	8464EZ	
	135,5	441,0	373,0	68	44,5	238,5	55	1°26'16"	6,5	300	8595HK	
	201,5	564,0	496,0	68	44,5	322,5	55	1°26'16"	6,5	300	606006	605085
	264,5	696,0	628,0	68	44,5	391,5	55	1°26'16"	6,5	300	606049	605123

Maßangaben in mm / Änderungen vorbehalten · Dimensions in mm / We reserve the right to make modifications · Dimensions en mm / Sous réserve de changements
08/04

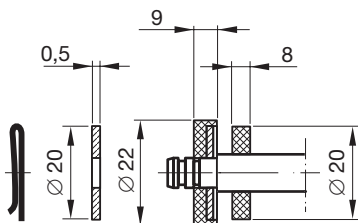
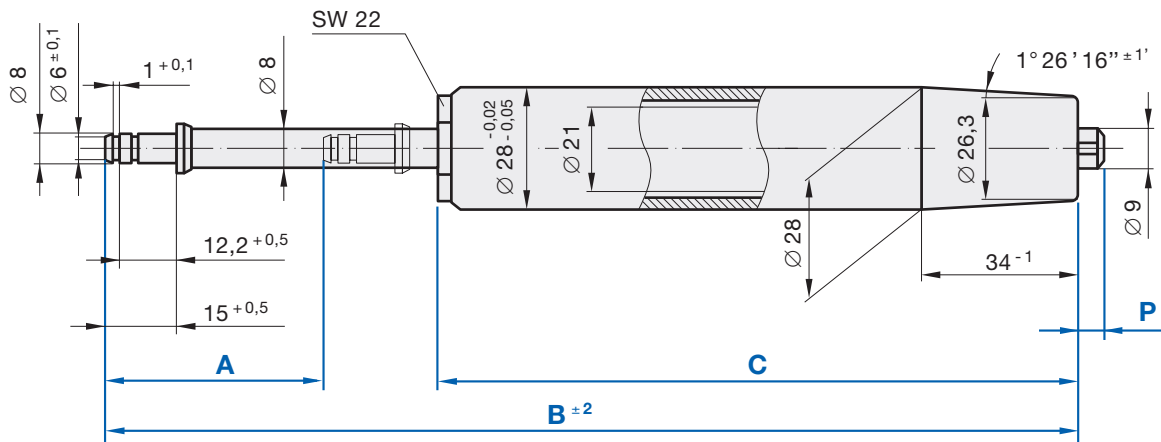
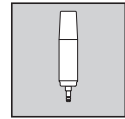

Axiallager Axial bearing set Butée à billes	Bestell-Nr. Ref.-No. Réf.-No.
7052LW	

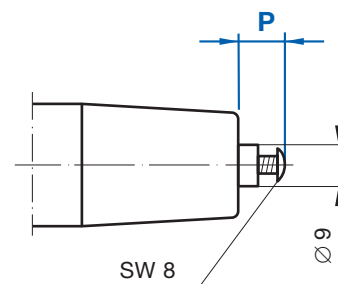

A	B	C	P	Stößel einstellbar	Axiallager montiert	Gasfeder auswechselbar	F ₁ - [N]	Bestell-Nr.
Hub	Ausgeschobene Länge	Druckrohr- länge	Stößel- überstand	Release pin adjustable	Axial bearing set assembled	Gas spring replaceable		Ref.-No.
Stroke	Extended length	Length of pressure tube	Release pin projection	Poussoir réglable	Butée à billes montée	Ressort à gaz échangeable		Réf.-No.
Course	Longueur sortie	Longueur du tube de pression	Dépassement du poussoir					
91,5	324,0	209,5	6,0	-	-	✓	400	0607BA
103,5	352,0	225,5	6,0	-	-	✓	400	735442
121,5	374,0	239,5	7,0	-	-	✓	300	1425AF
121,5	394,0	249,5	6,0	-	-	✓	300	740969
127,5	422,0	271,5	6,0	-	-	✓	310	711799
139,5	441,5	278,5	6,5	✓	✓	✓	310	701254
202,5	564,0	338,5	6,0	-	-	✓	300	0718BJ
265,5	696,0	407,5	6,0	-	-	✓	300	0728BD
271,5	708,5	413,5	6,5	✓	✓	✓	310	701084
100,0	354,0	224,0	6,0	-	-	-	400	7189DV
118,0	382,0	249,0	6,0	✓	-	-	300	6759CJ
122,0	394,0	255,0	6,0	-	✓	-	300	2067DJ

Maßangaben in mm / Änderungen vorbehalten · Dimensions in mm / We reserve the right to make modifications · Dimensions en mm / Sous réserve de changements
08/04

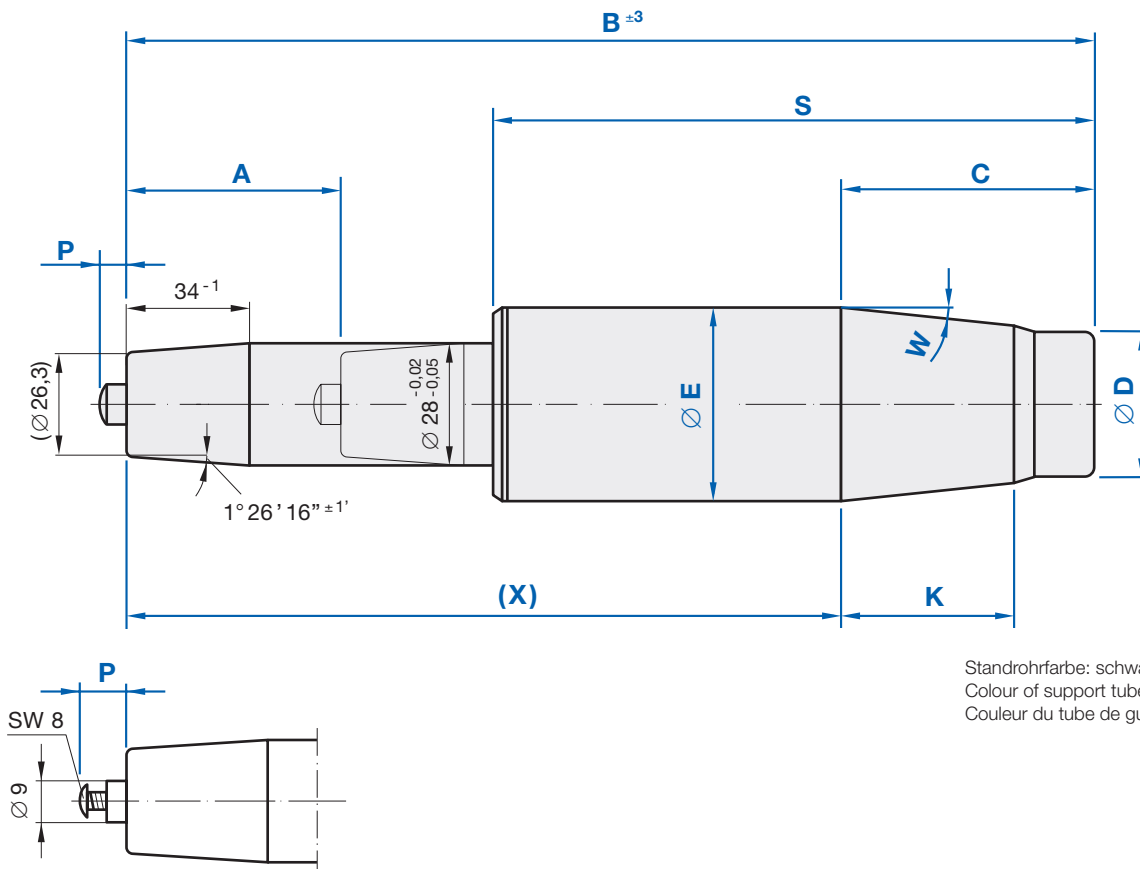
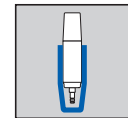

Standrohrfarbe: schwarz lackiert
Colour of support tube: black paint finish
Couleur du tube de guidage: laqué noir

ø E	A	B	X	C	ø D	S	K	W	P	Stößel einstellbar	Gasfeder auswechselbar	F1 - [N]	Bestell-Nr. Ref.-No. Réf.-No.
Standrohr- durchmesser	Hub	Ausgesch. Länge	Fußkreuz- maß			Standrohr- länge	Konus II Länge	Konus II Winkel	Stößel Überstand	Screw adjustable	Gas spring replaceable		
Outer tube diameter	Course	Extended length	Dimension of chair base			Longueur du tube de guidage	Cône II length	Cône II angle	Release pin projection	Poussoir réglable	Ressort à gaz échangeable		
Diamètre de colonne	Course	Longueur sortie	Dimensionne- ment piétement				Cône II longueur	Cône II angle	Dépassement du poussoir				
50	89,5	326,5	255,5	71	44,50	192,5	55	1°26'16"	6,00	-	✓	400	9011DN
	88,5	353,0	260,0	93	40,50	175,5	60	1°26'16"	6,00	-	✓	350	700401
	134,0	414,0	329,0	85	46,75	225,5	65	1°26'16"	7,00	-	-	300	3334CR
50	103,0	334,5	240,5	94	44,50	188,5	55	1°26'16"	7,00	-	-	450	3037BA
	121,0	404,5	276,5	128	44,50	215,5	55	1°26'16"	7,00	-	-	300	4571CN
	121,0	414,5	288,5	126	44,50	232,5	45	1°26'16"	7,00	-	-	300	4541CE
	130,0	404,0	312,0	92	45,50	223,5	90	1°26'16"	5,50	✓	-	300	1901FM
	109,5	386,5	321,5	65	44,50	218,5	45	1°26'16"	6,00	✓	✓	300	969303
	127,0	440,5	332,5	108	44,50	238,5	45	1°26'16"	6,00	-	-	300	5895DC
	125,0	417,5	354,5	63	44,50	229,5	45	1°26'16"	6,00	-	-	300	930466
	152,0	494,5	409,5	85	44,50	276,5	45	1°26'16"	7,00	-	-	300	2712CT

Maßangaben in mm / Änderungen vorbehalten · Dimensions in mm / We reserve the right to make modifications · Dimensions en mm / Sous réserve de changements
08/04

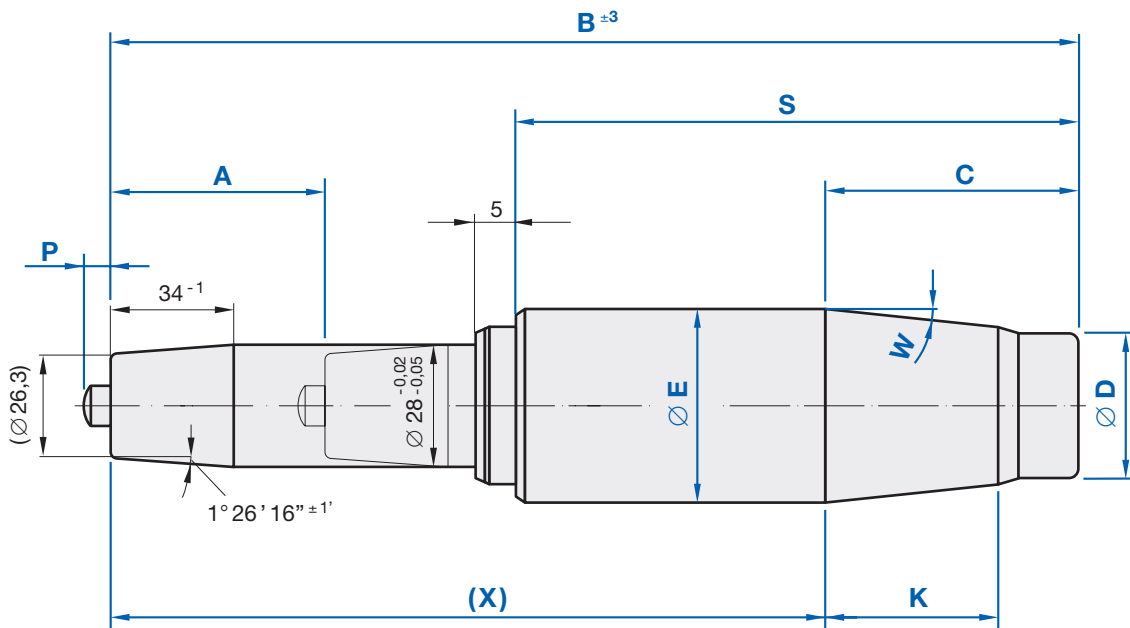
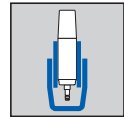

Standrohrfarbe: schwarz lackiert
Colour of support tube: black paint finish
Couleur du tube de guidage: laqué noir

Ø E Standrohr- durchmesser Outer tube diameter Diamètre de colonne	A Hub Stroke Course	B Ausgesch. Länge Extended length Longueur sortie	X Fußkreuz- maß Dimension of chair base Dimensionne- ment piétement	C	Ø D	S Standrohr- länge Length of support tube Longueur du tube de guidage	K Konus II Länge Cone II length Cône II longueur	W Konus II Winkel Cone II angle Cône II angle	P Stößel- überstand Release pin projection Dépassement du poussoir	F ₁ - [N]	Bestell-Nr. Ref.-No. Réf.-No.
50	125,5	378,5	289,5	92,0	46,75	202,5	65	1°26'16"	6,5	300	7002CH
	159,5	444,5	352,5	92,0	44,5	204,5	78	1°26'16"	7,5	400	1365GV
	204,5	535,5	443,5	92,0	44,5	249,5	78	1°26'16"	7,5	300	853593
50,8	204,5	539,5	450,0	89,5	45,5	249,5	67	1°26'16"	6,5	300	5673DL

Maßangaben in mm / Änderungen vorbehalten · Dimensions in mm / We reserve the right to make modifications · Dimensions en mm / Sous réserve de changements
08/04

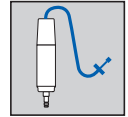
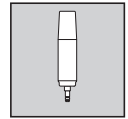
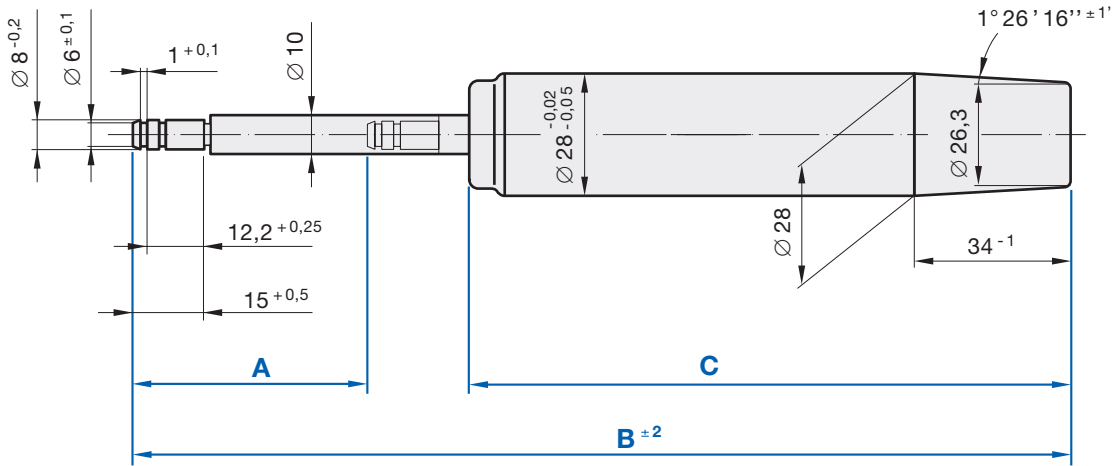

A	B	C	F1 - [N]	Bestell-Nr.
Hub	Ausgeschobene Länge	Druckrohr-länge		
Stroke	Extended length	Length of pressure tube		Ref.-No.
Course	Longueur sortie	Longueur du tube de pression		Réf.-No.
87,5	384,5	242	300	7478FD
135,5	439,5	282	300	8585DF

Bowdenzug-länge	Bestell-Nr.
Length of bowden-wire	Ref.-No.
Longueur du câble bowden	Réf.-No.
300	961698
400	9718CO
500	3603CT
700	9721CQ

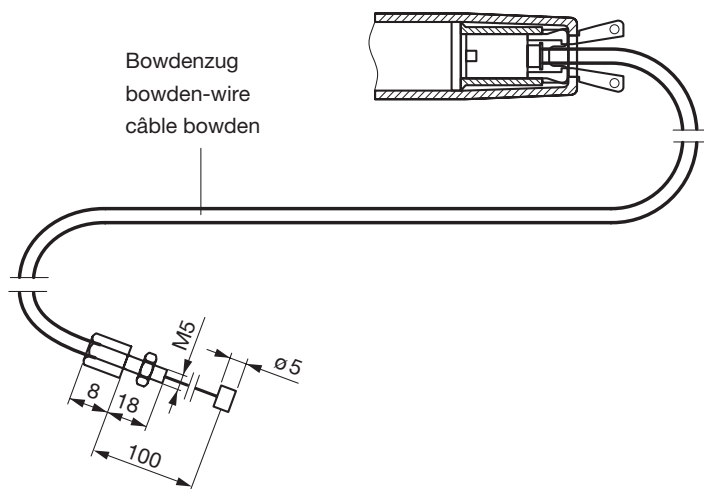

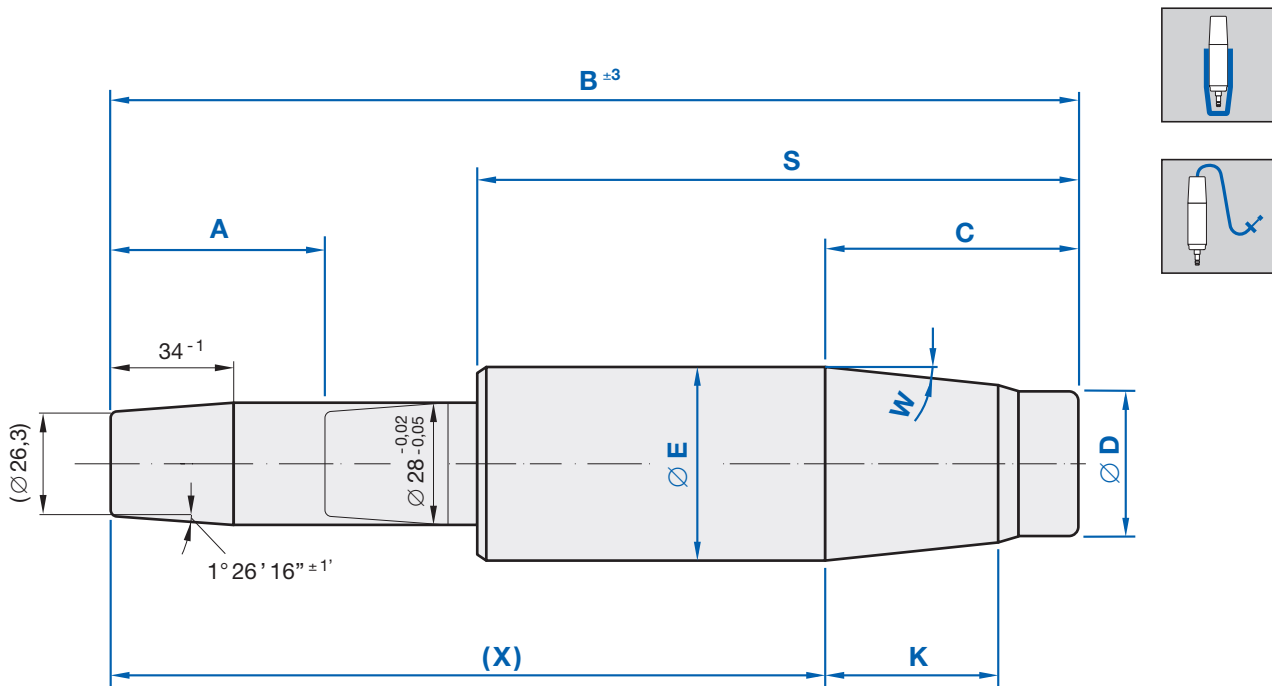

Standrohrfarbe: schwarz lackiert
Colour of support tube: black paint finish
Couleur du tube de guidage: laqué noir

øE Standrohr- durchmesser Outer tube diameter Diametre de colonne	A Hub Stroke Course	B Ausgesch. Länge Extended length Longueur sortie	X Fußkreuz- maß Dimension of chair base Dimensionne- ment piètement	C	øD	S Standrohr- länge Length of support tube Longueur du tube de guidage	K Konus II Länge Cone II length Cône II longueur	W Konus II Winkel Cone II angle Cône II angle	F ₁ - [N]	Bestell-Nr. Ref.-No. Réf.-No.
50	87,5	386	303	83	44,5	224,5	55	1°26'16"	300	0588DA
	119,5	433	324	109	44,5	236,5	55	1°26'16"	300	8822DI

Bowdenzug- länge Length of bowden-wire Longueur du câble bowden	Bestell-Nr. Ref.-No. Réf.-No.
300	961698
400	9718CO
500	3603CT
700	9721CQ

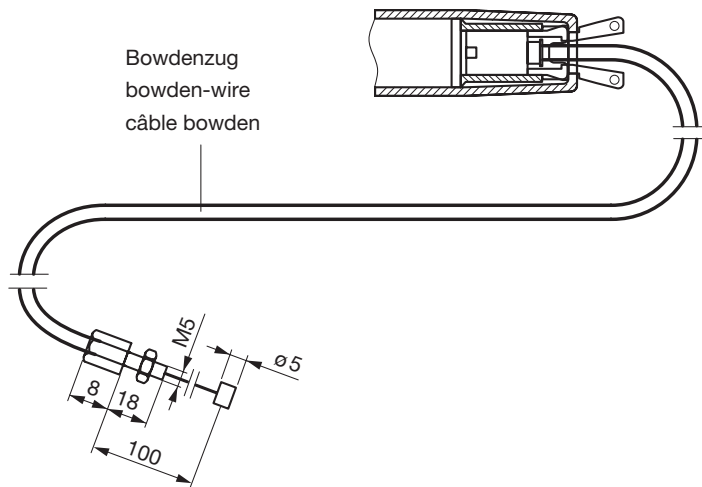

Maßangaben in mm / Änderungen vorbehalten · Dimensions in mm / We reserve the right to make modifications · Dimensions en mm / Sous réserve de changements
08/04

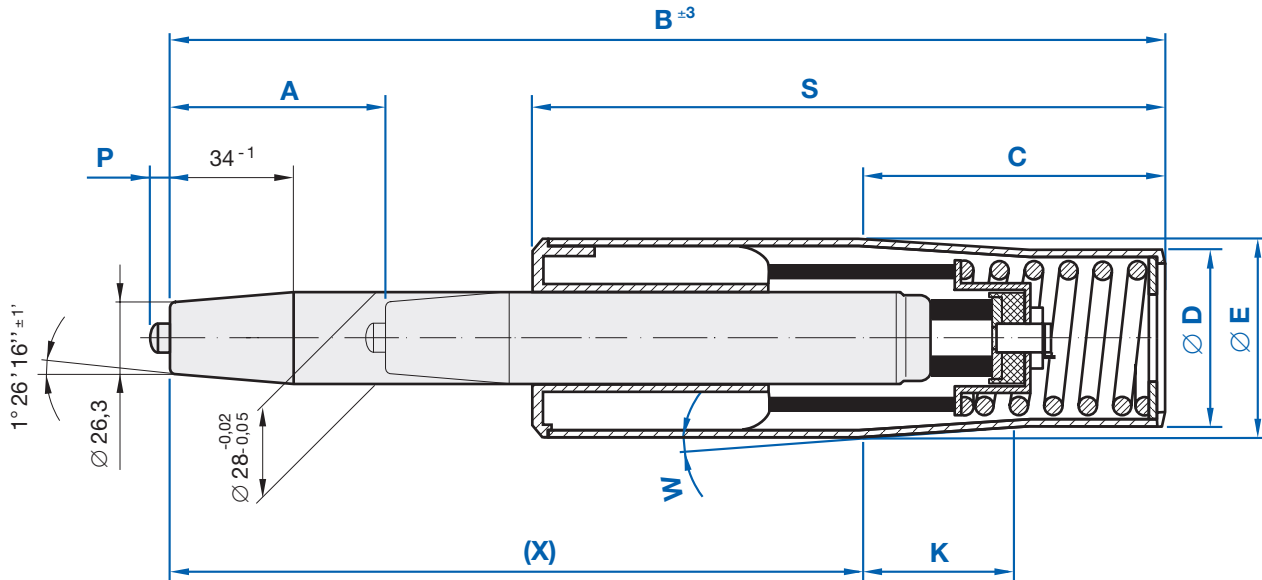
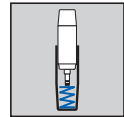

Standrohrfarbe: schwarz lackiert
Colour of support tube: black paint finish
Couleur du tube de guidage: laqué noir

Ø E Standrohr- durchmesser Outer tube diameter Diamètre de colonne	A Hub Stroke Course	B Ausgesch. Länge Extended length Longueur sortie	X Fußkreuz- maß Dimension of chair base Dimensionnement piètement	C	Ø D	S Standrohr- länge Length of support tube Longueur du tube de guidage	K Konus II Länge Cone II length Cône II longueur	W Konus II Winkel Cone II angle Cône II angle	P Stößel- überstand Release pin projection Dépassement du poussoir	F1 - [N]	Bestell-Nr. Ref.-No. Réf.-No.
50	81,5	328,5	257	71,5	46,4	175	71,5	1°26'16"	6,5	400	0915AR
	96,5	356,5	285	71,5	46,4	178	71,5	1°26'16"	6,5	350	9207CG
	111,5	401,5	330	71,5	46,4	192	71,5	1°26'16"	6,5	350	9213CU
	126,5	436,5	365	71,5	46,4	234	71,5	1°26'16"	6,5	300	971510
	135,5	435,5	364	71,5	46,4	219	71,5	1°26'16"	6,5	350	9218CW

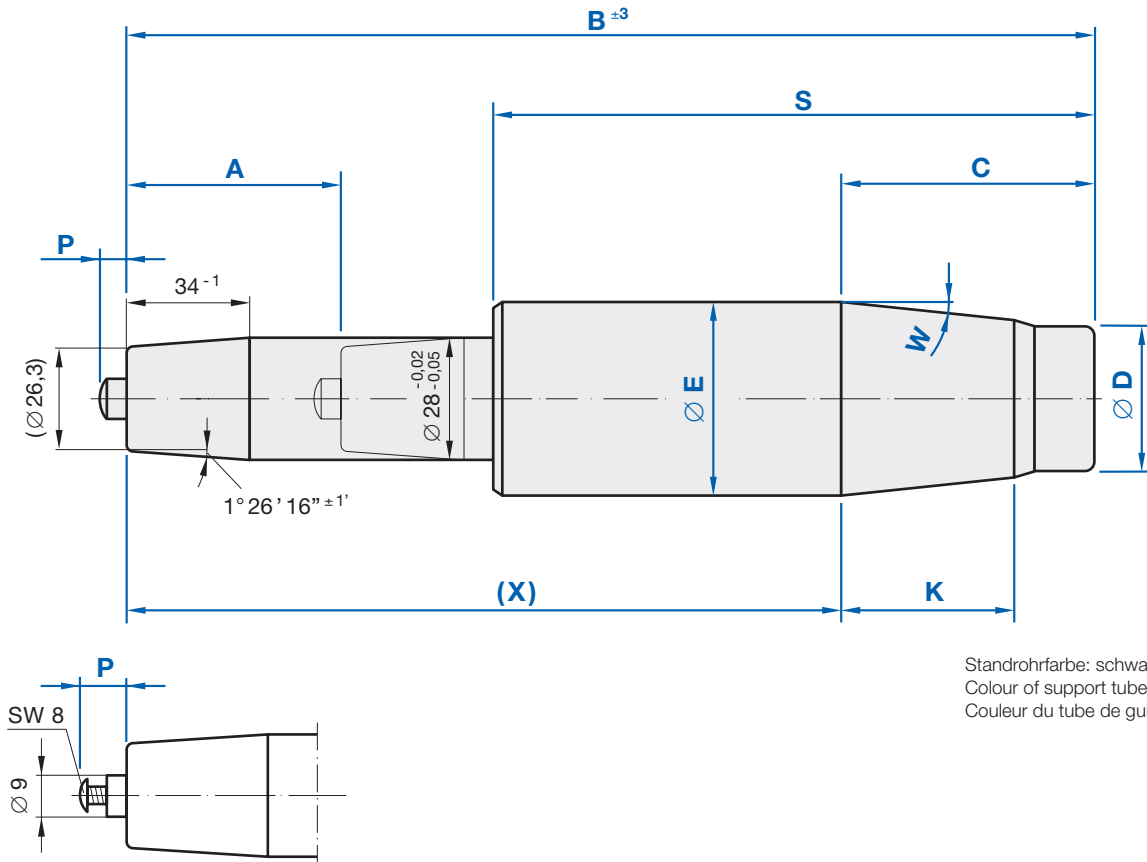
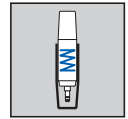

Standrohrfarbe: schwarz lackiert
Colour of support tube: black paint finish
Couleur du tube de guidage: laqué noir

Ø E	A	B	X	C	Ø D	S	K	W	P	Stößel einstellbar	Gasfeder austauschbar	F1 - [N]	Bestell-Nr. Ref.-No. Réf.-No.
Standrohrdurchmesser Outer tube diameter Diamètre de colonne	Hub Stroke Course	Ausgesch. Länge Extended length Longueur sortie	Fußkreuzmaß Dimension of chair base Dimensionnement piètement			Standrohrlänge Length of support tube Longueur du tube de guidage	Konus II Länge Cone II length Cône II longueur	Konus II Winkel Cone II angle Cône II angle	Stößelüberstand Release pin projection Dépassement du poussoir	Screw adjustable Poussoir réglable	Gas spring replaceable Ressort à gaz échangeable		
50	102,5	353,0	258,0	95	46,75	196,5	65	1°26'16"	6,0	-	-	300	8952LF
	117,5	390,5	304,5	86	46,75	219,5	65	1°26'16"	6,0	-	-	310	5931CB
	132,5	417,0	327,0	90	46,75	232,5	65	1°26'16"	5,5	✓	-	350	670596
	122,5	415,0	350,0	65	46,75	234,5	65	1°26'16"	6,0	-	-	300	8734LV
	125,5	427,0	362,0	65	46,75	237,5	65	1°26'16"	6,0	✓	-	330	8955LR

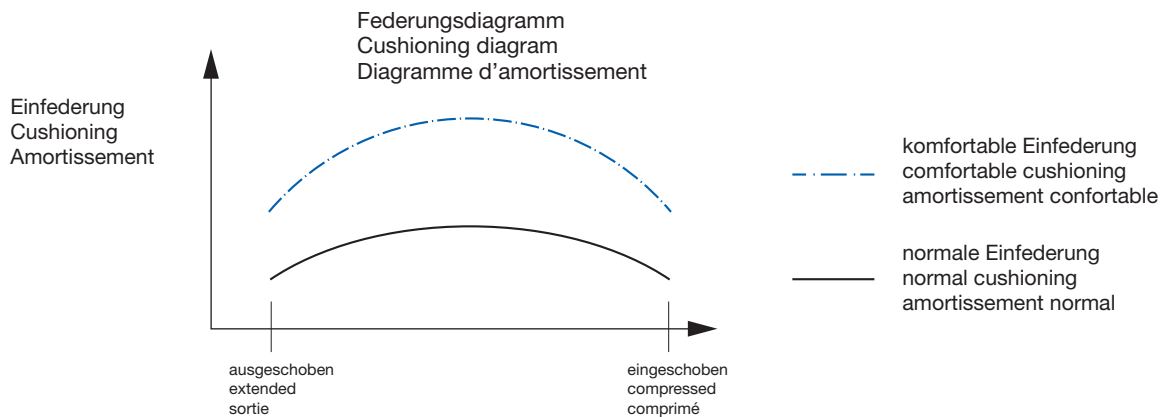

Maßangaben in mm / Änderungen vorbehalten · Dimensions in mm / We reserve the right to make modifications · Dimensions en mm / Sous réserve de changements
08/04

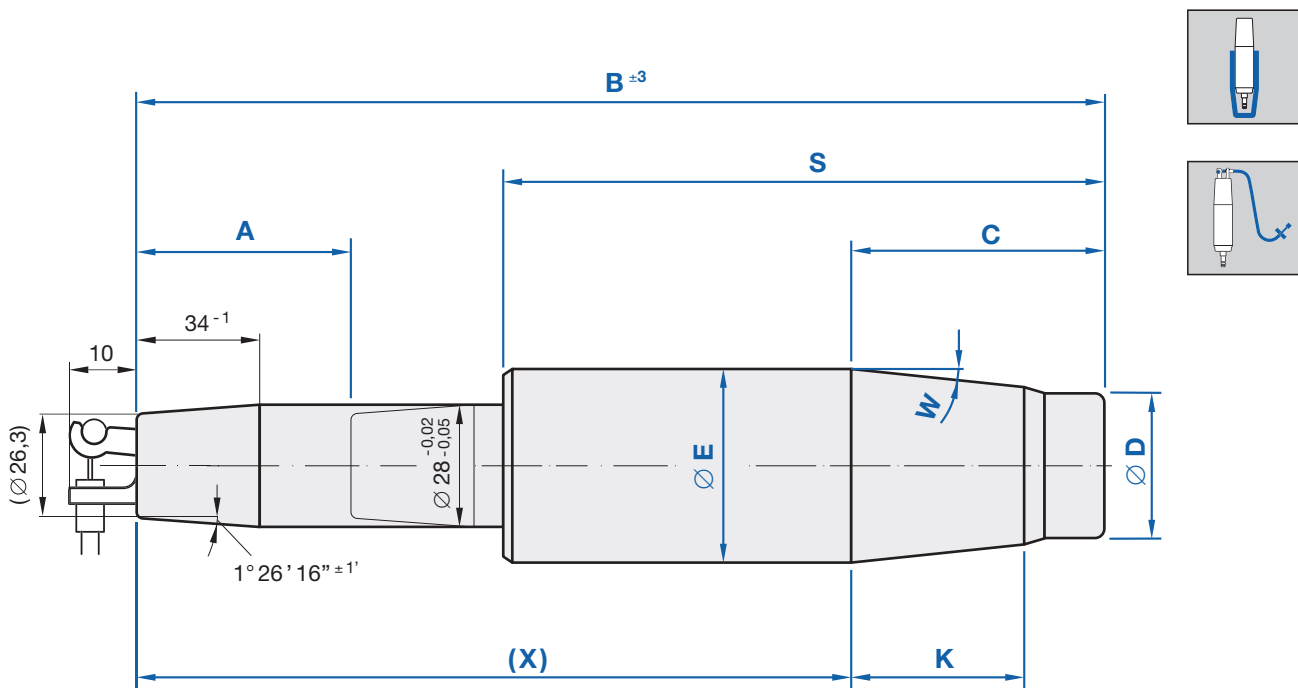

Standrohrfarbe: schwarz lackiert
Colour of support tube: black paint finish
Couleur du tube de guidage: laqué noir

ø E	A	B	X	C	ø D	S	K	W	F1 - [N]	Bestell-Nr.
Standrohrdurchmesser Outer tube diameter Diamètre de colonne	Hub Stroke Course	Ausgesch. Länge Extended length Longueur sortie	Fußkreuzmaß Dimension of chair base Dimensionnement piètement			Standrohrlänge Length of support tube Longueur du tube de guidage	Konus II Länge Cone II length Cône II longueur	Konus II Winkel Cone II angle Cône II angle		Ref.-No. Réf.-No.
50	135	419	296	123	44,5	239,5	55	1°26'16"	300	3694PQ

A	Bowdenzuglänge Length of bowden-wire Longueur du câble bowden	Bestell-Nr. Ref.-No. Réf.-No.
	200	0345BH
	300	878189
	400	7605AV
	500	0346BC
	600	0347BY

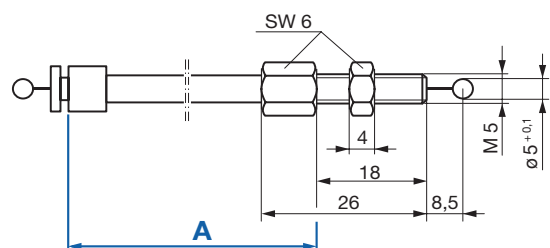

Maßangaben in mm / Änderungen vorbehalten · Dimensions in mm / We reserve the right to make modifications · Dimensions en mm / Sous réserve de changements
08/04

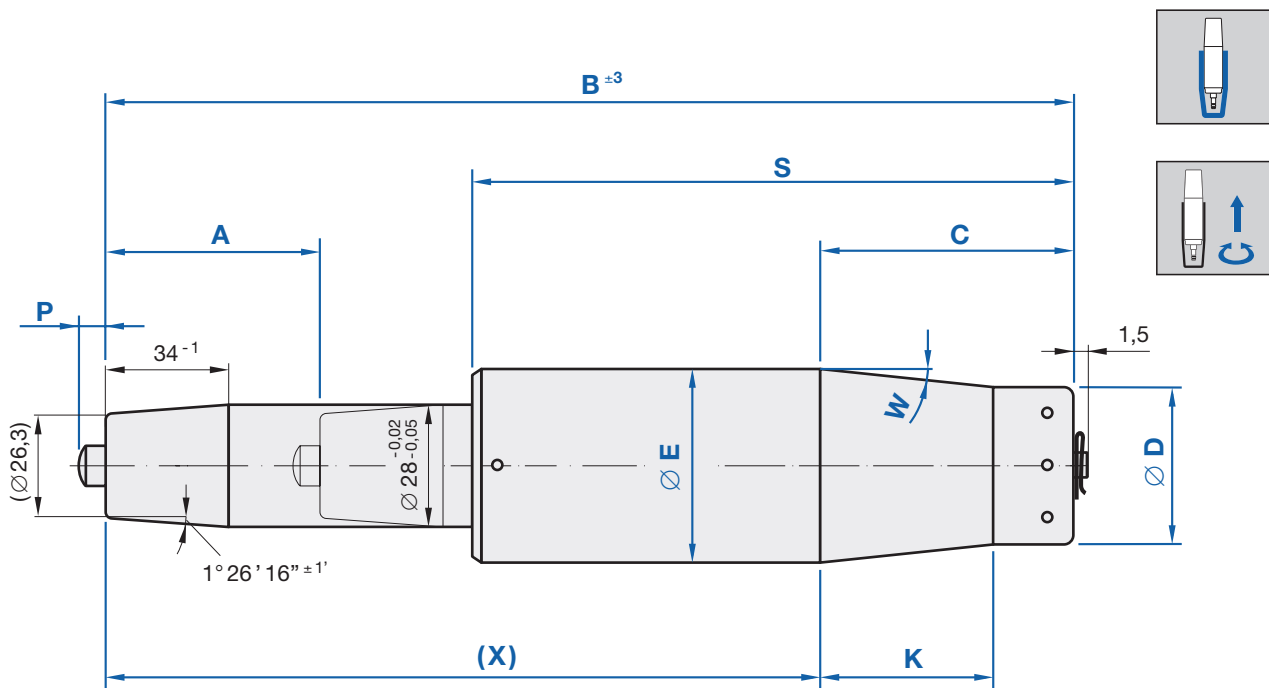

ø E	A	B	X	C	ø D	S	K	W	P	F1 - [N]	Bestell-Nr. / Ref.-No. / Réf.-No. Standrohrfarbe Colour of support tube Couleur du tube de guidage schwarz lackiert black paint finish laqué noir
Standrohr- durchmesser Outer tube diameter Diametre de colonne	Hub Stroke Course	Ausgesch. Länge Extended length Longueur sortie	Fußkreuz- maß Dimension of chair base Dimensionnement piètement			Standrohr- länge Length of support tube Longueur du tube de guidage	Konus II Länge Cone II length Cône II longueur	Konus II Winkel Cone II angle Cône II angle	Stößel- überstand Release pin projection Dépassement du poussoir		
50	67,5	337,0	222,0	115	46,75	222,5	65	1°26'16''	6,5	300	3693IW
	67,5	344,0	249,0	95	46,75	222,5	65	1°26'16''	6,5	400	2026LG
	104,5	397,0	322,0	75	46,75	247,5	65	1°26'16''	6,5	300	1149GA

Maßangaben in mm / Änderungen vorbehalten · Dimensions in mm / We reserve the right to make modifications · Dimensions en mm / Sous réserve de changements
08/04

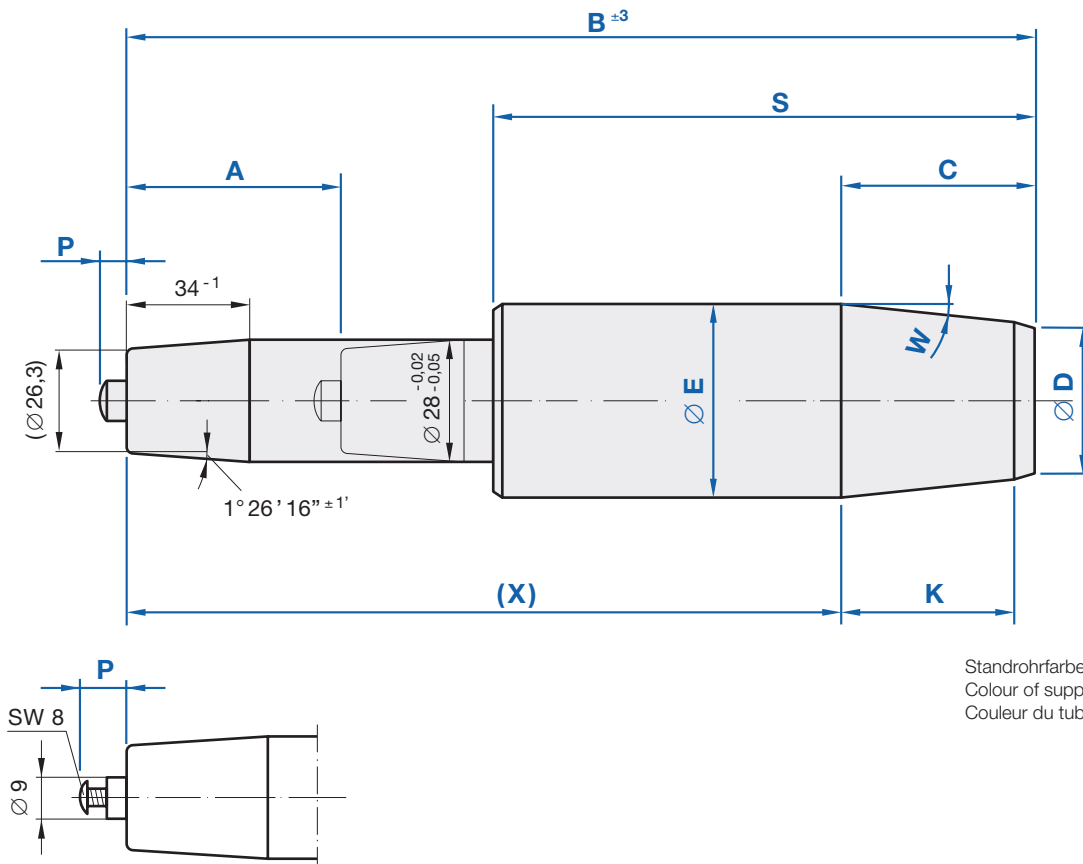
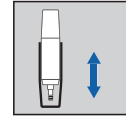
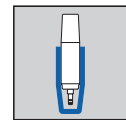

Standrohrfarbe: schwarz lackiert
Colour of support tube: black paint finish
Couleur du tube de guidage: laqué noir

∅ E Standrohr- durchmesser Outer tube diameter Diametre de colonne	A Hub Stroke Course	B Ausgesch. Länge Extended length Longueur sortie	X Fußkreuz- maß Dimension of chair base Dimensionne- ment piétement	C	S Standrohr- länge Length of support tube Longueur du tube de guidage	W Konus II Winkel Cone II angle Cône II angle	P Stößel- überstand Release pin projection Dépassement du poussoir	Stößel einstellbar Screw adjustable Poussoir réglable	F1 - [N]	Bestell-Nr. / Ref.-No. / Réf.-No. Standrohrfarbe Colour of support tube Couleur du tube de guidage	
										schwarz lackiert black paint finish laqué noir	matt verchromt dull chromed chromé mat
50	135,5	416,5	351,5	65	237,5	1°26'16"	6	-	300	2091HF	
	165,5	505,5	440,5	65	286,5	1°26'16"	7	✓	300		0717HR
	201,5	565,5	500,5	65	322,5	1°26'16"	6	-	300	6296HP	

Max. Verdrehmoment : 50 Nm
Maxim overtorque : 50 Nm
Couple de rotation maxi : 50 Nm

Maßangaben in mm / Änderungen vorbehalten · Dimensions in mm / We reserve the right to make modifications · Dimensions en mm / Sous réserve de changements
08/04

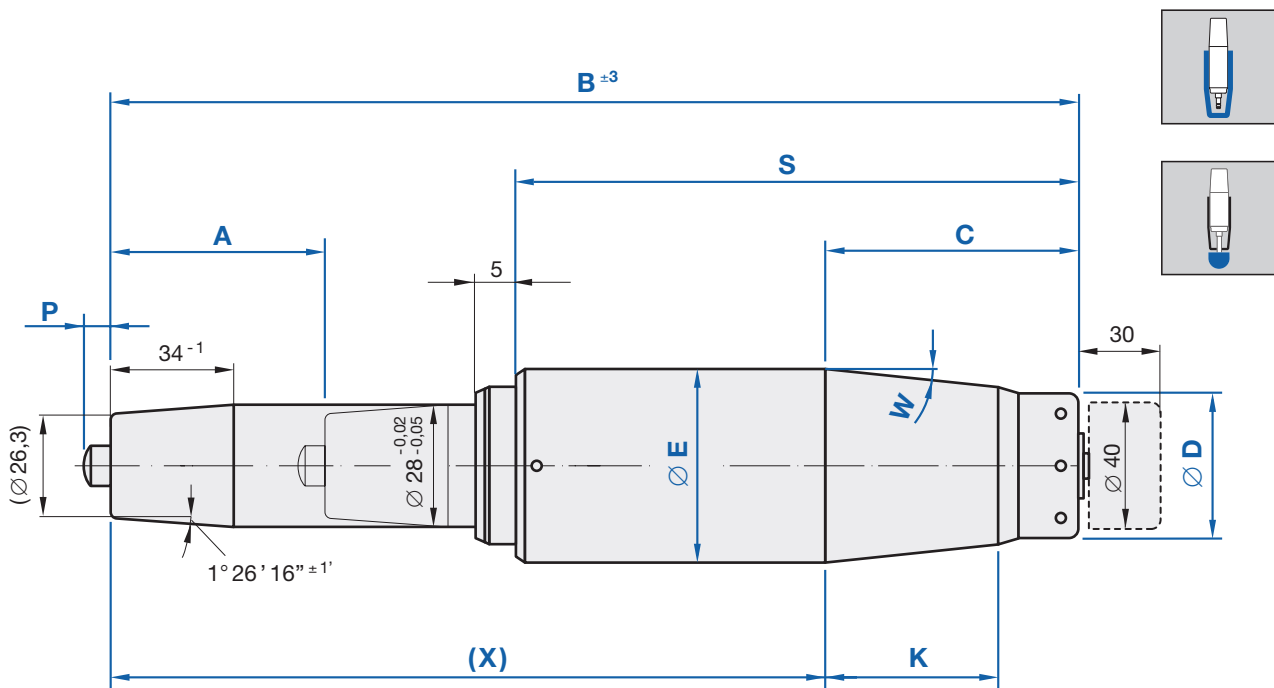

Standrohrfarbe: schwarz lackiert
Colour of support tube: black paint finish
Couleur du tube de guidage: laqué noir

Ø E	A	B	X	C	Ø D	S	K	W	P	Bereich ① Range ② Zone ②	F1 - [N]	Bestell-Nr. Ref.-No. Réf.-No.
Standrohr- durchmesser Outer tube diameter Diametre de colonne	Hub Stroke Course	Ausgesch. Länge Extended length Longueur sortie	Fußkreuz- maß Dimension of chair base Dimensionne- ment piètement			Standrohr- länge Length of support tube Longueur du tube de guidage	Konus II Länge Cone II length Cône II longueur	Konus II Winkel Cone II angle Cône II angle	Stößel- überstand Release pin projection Dépassement du poussoir			
50	175	495,0	392,0	103	46,75	257,5	65	1°26'16"	6	495,0 - 398,0	350	4484NJ
	188	526,5	446,5	80	46,75	266,5	65	1°26'16"	6	526,5 - 481,0	350	0289PW
	208	558,0	483,0	85	46,75	281,5	65	1°26'16"	6	558,0 - 438,0	350	4327NK
	220	580,0	477,0	103	46,75	293,5	65	1°26'16"	6	580,0 - 460,0	350	1826NE

Hinweis! Bitte beachten
Notice! Please observe
Remarque! À observer s.v.pl.!

Einbauvorschrift
Installation instruction **STAB-Spec. 1000 5593**
Instruction de montage

- Standard Höhenverstellung
Standard Height Adjustment
Règlage en hauteur standard
- Höhenverstellung mit Stopp-Funktion
Height Adjustment with stop-function
Règlage en hauteur standard avec fonction d'arrêt

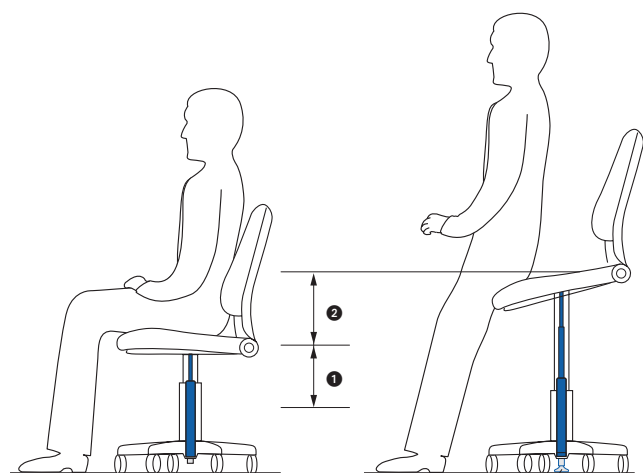

Gummi-Stopper
Rubber bumper
Arrêt-oir caoutchouc

Maßangaben in mm / Änderungen vorbehalten · Dimensions in mm / We reserve the right to make modifications · Dimensions en mm / Sous réserve de changements
08/04

Auslösemechanik für Höhenverstellung
Release mechanism for height adjustment
Mécanisme de déclenchement pour réglage de hauteur

Zubehör
Accessories
Accessoires

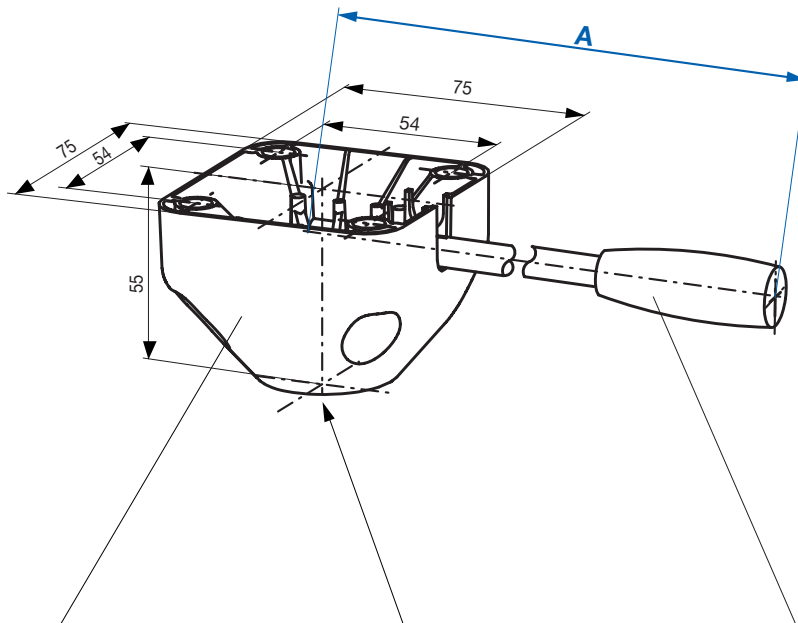

geeignet für Stühle mit
suitable for swivel-chairs with
approprié pour les sièges avec

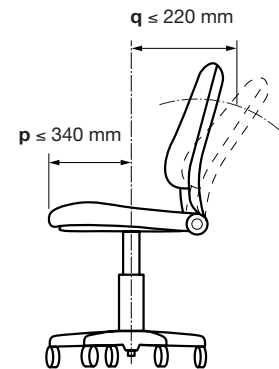

nach
according to
selon la norme **DIN 4551**

Auslösekopf
Release head
Tête de déclenchement

Konus $\varnothing 28 \times 34$ G 09 K2
Cone
Cône

Auslösehebel
Release lever
Lever de déclenchement

im Stuhl nur seitliche Montage zulässig
in chairs, only lateral assembly allowed
sur chaise, seul un assemblage latéral
est permis

Schraubverbindung gegen Lösen sichern
Empf. Schrauben-Anzugsmoment : 10 Nm
Protection against thread loosening
Recommended tightening torque : 10 Nm für Stößelüberstand $6,5^{\pm 1}$
Assurer l'anti - desserrage des vis : 10 Nm für release pin length $6,5^{\pm 1}$
Couple de serrage recommandé pour le vissage : 10 Nm pour dépassement du poussoir $6,5^{\pm 1}$

A Länge des Auslösehebels Length of release lever Longueur du levier de déclenchement	Bestell-Nr./Ref.-No./Réf.-No. Auslösekopf incl. Hebel Release head incl. lever Tête de déclenchement inclus levier	Bestell-Nr./Ref.-No./Réf.-No. Auslösekopf ohne Hebel Release head without lever Tête de déclenchement sans levier
ca. 221	7616PW	0119PR
ca. 171	7617PR	

Kunststoffbuchse schwarz
Plastic bush black
Douille plastique noire

Zubehör
 Accessories
 Accessoires

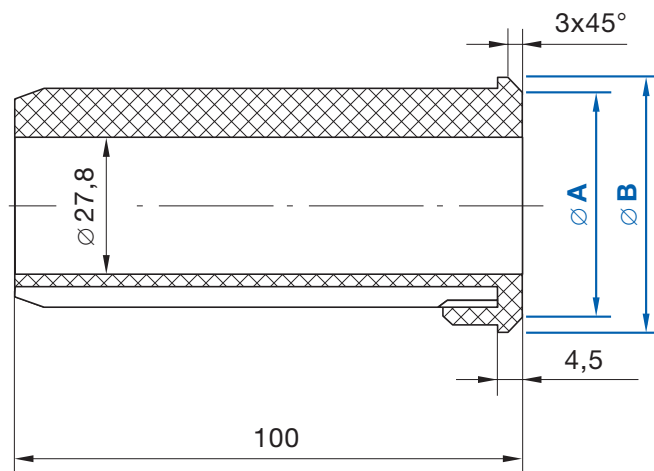

A Durchmesser der Führungsbuchse Diameter of guide bush Diametre de la douille de guidage	B Standrohrdurchmesser Outer tube diameter Diametre de colonne	Bestell-Nr. Ref.-No. Réf.-No.
34,2	38	044881
36,2	40	195626
42,2	45	022861
46,2	50	560405

Notizen / Notes / Notes

A large grid of graph paper for taking notes, consisting of 20 columns and 30 rows of small squares.

Tipps und Hinweise zum richtigen Einbau von Gasfedern

Anwendung

Gasfedern sind in ihrer technischen Auslegung auf die speziellen Anwendungen abzustimmen. Grundlage hierfür sind Spezifikationen und Zeichnungen. Nach Möglichkeit sollte die Anwendung und Anforderung mit Stabilus abgestimmt werden.

Einbaulage

Vorzugsweise sollten Gasfedern - außer sie sind für lageunabhängigen Einbau vorgesehen - mit im Ruhezustand nach unten gerichteter Kolbenstange eingebaut werden. Dadurch wird stets für eine optimale Schmierung des Führungs- und Dichtungssystems gesorgt.

Verkantungsfrei

Um die Lebensdauer nicht zu beeinträchtigen, dürfen Gasfedern keine Verkantungen, Biege- oder Querkräfte erfahren. Durch geeignete Anschluss-Stücke wie z.B. Winkelgelenke kann die verkantungsfreie Anlenkung sichergestellt werden.

Funktionssicherheit

Die Funktionssicherheit der Gasfeder ergibt sich maßgeblich durch die glatte Kolbenstangenoberfläche und durch Dichtungen, die den Gasdruck im Inneren halten. Um sie zu schützen, dürfen keine Biegebelastungen auf die Gasfeder ausgeübt werden. Beschädigungen durch nachträgliche mechanische Bearbeitung oder gar Schweißungen an der Gasfeder sowie Verunreinigungen oder Farbe auf der Kolbenstange können zum Ausfall der Geräte führen. Änderungen und Manipulationen, Schlageinwirkung, Zugbelastungen, Erhitzen, Überlackieren oder die Aufdruckentfernung sind zu vermeiden. Nicht ordnungsgemäße Produkte dürfen nicht der Nutzung zugeführt werden.

Temperaturbereich

Der Standardtemperaturbereich, für den Stabilus Gasfedern ausgelegt sind, liegt zwischen -30°C und +80°C. Selbstverständlich sind auch Gasfedern für extremere Belastungen verfügbar.

Lebensdauer und Wartung

Gasfedern sind wartungsfrei! Es bedarf keiner Wartung wie Ölen oder Fetten. Sie sind stets für die jeweiligen Anforderungen ausgelegt und arbeiten über viele Jahre hinweg störungsfrei.

Transport und Lagerung

Wenn Gasfedern eingelagert werden, sollte dies vorzugsweise mit nach unten gerichteter Kolbenstange erfolgen. Nach einer maximalen Lagerzeit von 6 Monaten sollten die Gasfedern betätigt werden. Um Beschädigungen zu vermeiden, sollten Gasfedern nicht als Schüttgut transportiert werden. Verunreinigungen, insbesondere auch durch dünne Verpackungsfolien oder Klebebänder sind zu vermeiden.

Entsorgung

Werden Gasfedern nicht mehr benötigt, sollten sie umweltgerecht entsorgt werden. Dazu werden sie geeignet aufgebohrt, um das komprimierte Stickstoffgas sowie das enthaltene Öl abzulassen. Genauere Hinweise dazu sind der STAB-Spec. 1000 9375 zu entnehmen bzw. finden Sie unter www.stabilus.de/recycling.

Tips and Hints for the Proper Installation of Gas Springs

Application

The gas spring technical design must be matched to the respective application. The basis for this are the specifications and drawings. If possible, the application and requirements should be discussed with Stabilus.

Installation Orientation

Whenever possible, gas springs should be installed so that the piston rod points down in the inactive state, as non-orientation-specific installation requires special consideration. This ensures optimum lubrication of the guidance and sealing system.

Unconstrained Motion

For a long service life, gas springs must not be subjected to bending forces applied through the end connections. The use of suitable end fittings, such as angled joints, ensures coupling without jamming.

Functional Safety

The functional safety is derived mainly from the smooth piston rod surface and the seals that hold the gas pressure inside. In order to protect them, the gas spring must not be subjected to any bending stress. Damage caused by mechanical machining, contaminants, or paint on the piston rod can cause the gas springs to fail. Furthermore, welding of the finished gas spring is explicitly not recommended. Modifications and manipulations, impact, tensile stress, heating, over-painting, or the removal of the imprint are also to be avoided. Noncompliant devices must not be put into use.

Temperature Range

Stabilus gas springs are designed for a temperature range of -30°C and +80°C. Of course, there are also specialized gas springs available for heavy-duty applications.

Lifetime and Maintenance

Gas springs are maintenance-free! They do not require greasing or lubrication. They are designed for their respective applications and, when properly installed, work flawlessly for many years.

Transportation and Storage

If storage of the gas springs is required, the preferred storage position is with the piston rod pointing down. After a maximum storage time of 6 months, the gas springs should be actuated. In order to avoid damage, gas springs should never be transported as bulk material. Furthermore, foils and adhesive tapes should be avoided, as they may damage the gas springs.

Disposal

When gas springs are no longer needed, they should be disposed of in an environmentally correct manner. To accomplish this, they should be drilled open, the compressed nitrogen gas released and the oil drained. For more specific details, please refer to www.stabilus.com/recycling or STAB specification 1000 9375.

Conseils et indications pour le montage correct de vérins pneumatiques

Utilisation

La conception technique des vérins pneumatiques doit être adaptée à chaque type d'utilisation. Elle est basée sur des spécifications et des plans. Dans la mesure du possible, l'utilisation et le cahier des charges devraient être établis en accord avec Stabilus.

Position de montage

Les vérins pneumatiques devraient - sauf s'ils sont prévus pour montage dans n'importe quelle position - être montés de telle sorte qu'en état de repos, la tige de piston soit dirigée vers le bas. Ainsi, on est assuré d'une lubrification optimale du système de guidage et d'étanchéité.

Absence de gauchissement

Afin de ne pas compromettre leur durée de vie, les vérins pneumatique ne doivent pas être soumis à des gauchissements ni à des forces de flexion ou à des forces transversales. Le fonctionnement exempt de gauchissement s'obtient en utilisant des éléments de raccordement appropriés, tels que par exemple des cages à rotule.

Sécurité de fonctionnement

La sécurité de fonctionnement du vérin pneumatique résulte dans une large mesure de l'état de surface de la tige de piston et des joints d'étanchéité, qui maintiennent la pression du gaz à l'intérieur du vérin. Pour les préserver, aucune force de flexion ne doit s'exercer sur le vérin pneumatique. Des endommagements provoqués par un usinage mécanique voire des soudures sur le vérin pneumatique ainsi que des salissures ou peintures sur la tige de piston peuvent conduire à la défaillance des appareils. Il convient d'éviter toute modification ou manipulation, choc, étirement, échauffement, peinture ou enlèvement des marquages. Les produits non corrects ne doivent pas être mis en utilisation.

Plage de température

La plage de température standard, pour laquelle les vérins pneumatiques Stabilus sont conçus, se situe entre -30 °C et +80 °C. Bien entendu, nous pouvons aussi fournir des vérins pneumatiques étudiés pour des contraintes plus extrêmes.

Durée de vie et maintenance

Les vérins pneumatique sont exempts de toute maintenance. Il n'est besoin ni d'huile, ni de graisse. Ils sont toujours conçus spécialement pour chaque type d'utilisation et fonctionnent sans problème pendant de longues années.

Transport et stockage

Tant que les vérins pneumatique sont stockés, il est préférable de le faire avec la tige de piston dirigée vers le bas. Après un stockage maximal de 6 mois, les vérins pneumatiques doivent être actionnés. Afin d'éviter toute détérioration, les vérins pneumatiques ne devraient pas être transportés en vrac. Compte tenu des accumulations d'électricité statique, il faut éviter les conditionnements sous feuille plastique et similaires.

Mise au rebut

Lorsque les vérins pneumatiques ont fini de servir, il convient de les rebuter dans le respect de l'environnement. A cet effet, ils sont percés de manière appropriée, afin de laisser s'échapper l'azote comprimé et afin de laisser s'écouler l'huile. On trouvera des indications plus précises dans la spécification STAB 1000 9375.

Notizen / Notes / Notes

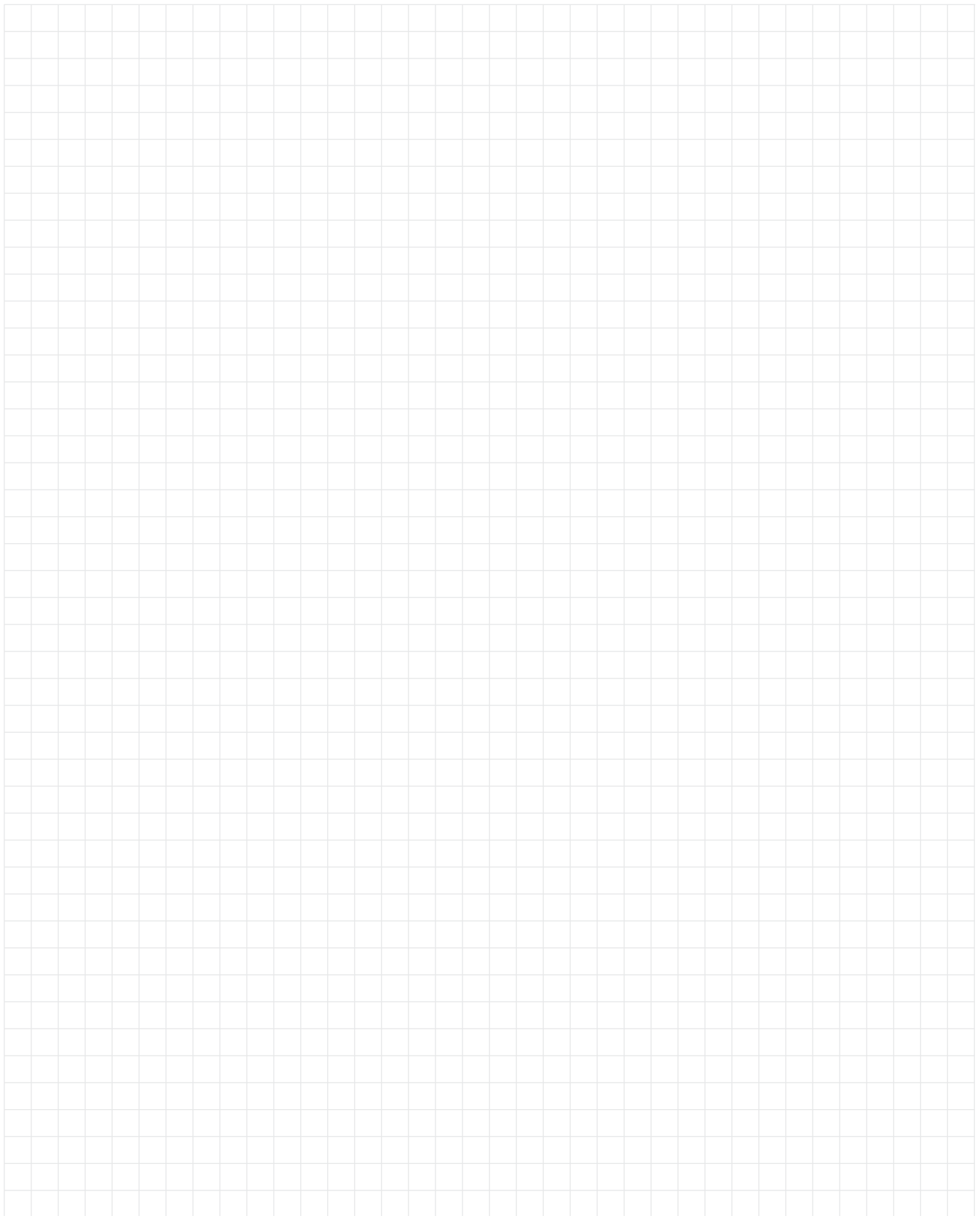

Notizen / Notes / Notes

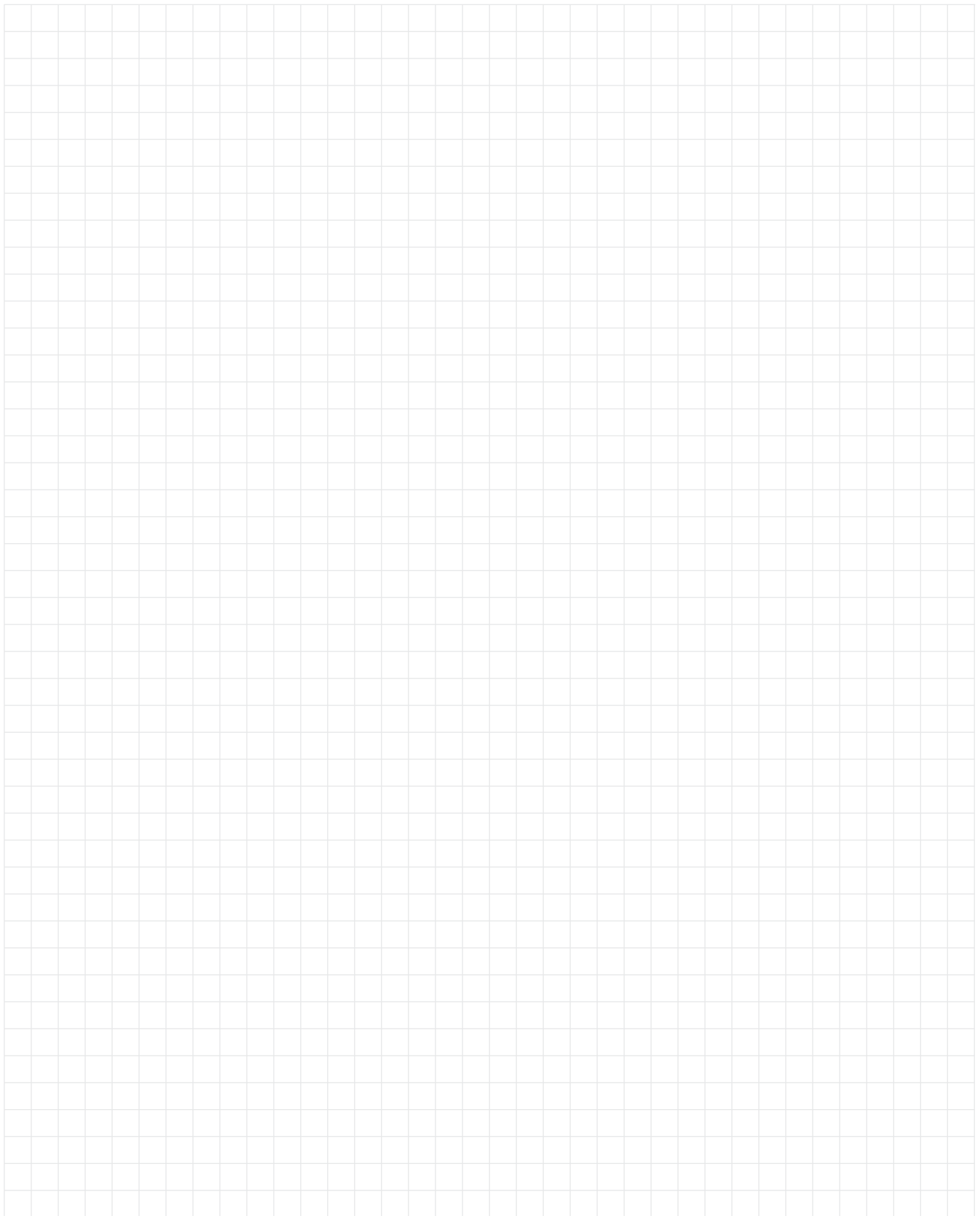

Notizen / Notes / Notes

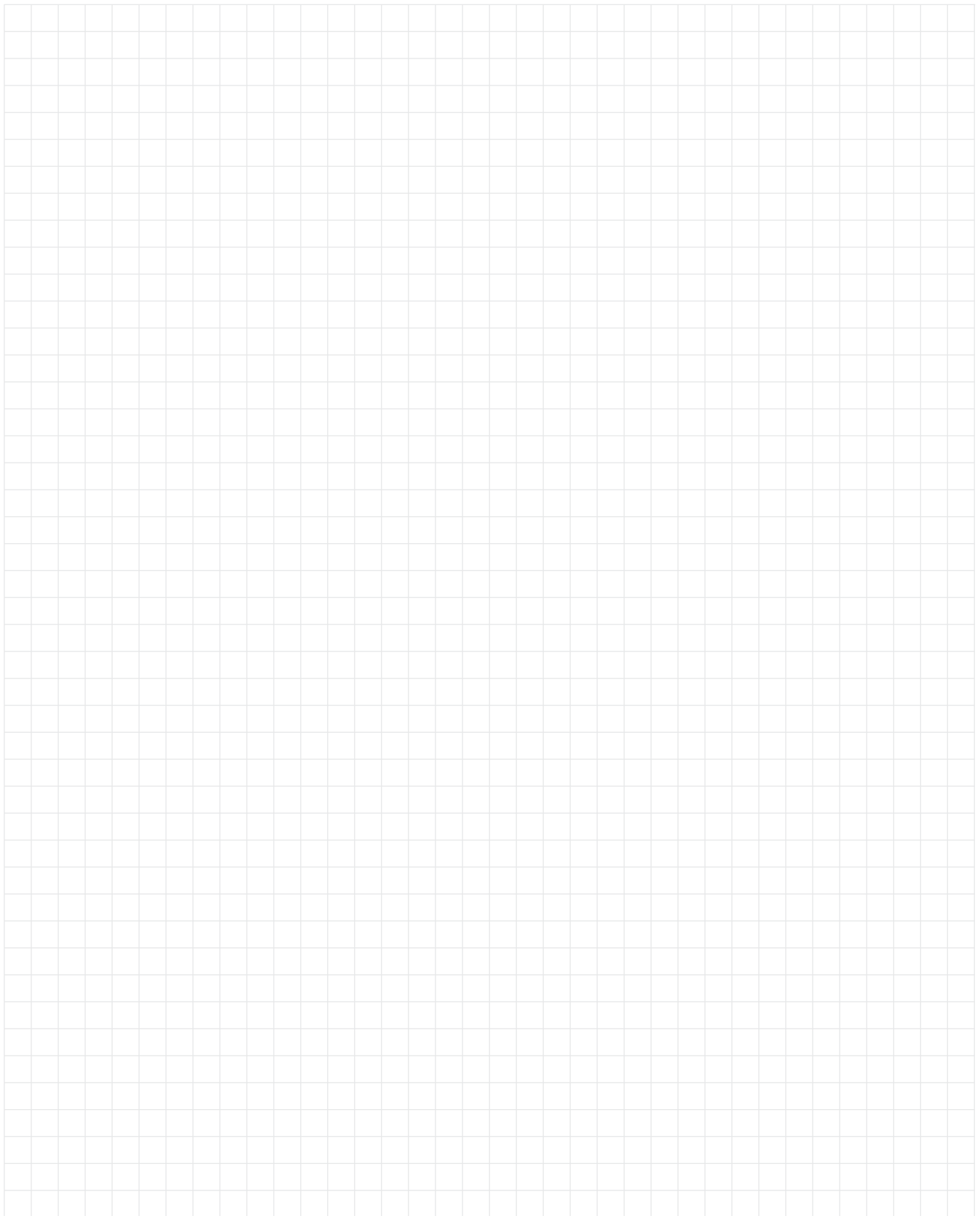



0008/08_04/ONM

No responsables por errores de impresión ó cambios.

Notre responsabilité n'est pas engagée en cas d'erreurs.

Not responsible for typographical errors.

Druckfehler und Änderungen vorbehalten.

Australia

Stabilus Pty. Ltd.
65 Redwood Drive
Dingley, VIC 3172
Australia
☎ ++61-3-9552-1400
📠 ++61-3-9552-1499
✉ info@au.stabilus.com

España

Stabilus España S. L.
Barrio Aretxalde, 128
48196 Lezama (Vizcaya)
España
☎ ++34-94-455-4170
📠 ++34-94-455-4183
✉ info@es.stabilus.com

Korea

Stabilus Sales Office
158-2, Seokchon-dong, Songpa-Gu
2nd Floor Bojeong building
138-844 Seoul
Korea
☎ ++82-2-422-0114
📠 ++82-2-421-0943
✉ info@kr.stabilus.com

Singapore

Stabilus Sales Office
c/o Sachs Southeast Asia Pte. Ltd.
No. 8 Jurong Town Hall Road
25-04 to 06, The JTC Summit
Singapore 609434
☎ ++65-822-7115
📠 ++65-822-7116
✉ info@sg.stabilus.com

USA

Sales Office Automotive
36225 Mound Road
Sterling Heights, MI 48310- 4739
USA
☎ ++1-586-977-2950
📠 ++1-586-446-3920
✉ info@us.stabilus.com

Brasil

Stabilus Ltda.
Av. Pres. Tancredo
de Almeida Neves, km 1,2
CEP 37.504-066 Itajubá (MG)
Brasil
☎ ++55-35-3629-5000
📠 ++55-35-3629-5005
✉ info@stabilus.com.br

Italia

Stabilus S.r.l.
Via Nazionale, 209
10069 Villar Perosa (To)
Italy
☎ ++39-0121-316-711
📠 ++39-0121-315-637
✉ info@it.stabilus.com

México

Stabilus, S.A. de C.V.
Industria Metalúrgica No. 1010
Parque Industrial Ramos Arizpe
C.P. 25900 Ramos Arizpe, Coahuila
México
☎ ++52-844-411-0707
📠 ++52-844-411-0706
✉ info@mx.stabilus.com

United Kingdom

Stabilus Ltd.
Beaumont Road
Banbury
Oxon. OX16 1QY
England
☎ ++44-1295-274-777
📠 ++44-1295-265-715
✉ info@uk.stabilus.com

USA

Sales Office Industrial
919 N. Plum Grove Road, Suite G
IL 60173 Schaumburg, Illinois
USA
☎ ++1-847-517-2980
📠 ++1-847-517-2987
✉ info@us.stabilus.com

Deutschland

Stabilus GmbH
Wallerheimer Weg 100
56070 Koblenz
Germany
☎ ++49-261-8900-0
📠 ++49-261-8900-204
✉ info@de.stabilus.com

Japan

Stabilus Japan Corporation
Toshin 24 Shinyokohama, Building B-8F
2-3-8 Shin-Yokohama, Kohoku-ku
222-0033 Yokohama
Japan
☎ ++81-45-471-2970
📠 ++81-45-471-2989
✉ info@jp.stabilus.com

New Zealand

Stabilus Limited
75 Ellice Rd. Glenfield
PO Box 101023 NSMC
Auckland
New Zealand
☎ ++64-9-444-5388
📠 ++64-9-444-5386
✉ info@stabilus.co.nz

USA

Stabilus Inc.
1201 Tulip Drive
Gastonia NC 28052 - 1898
USA
☎ ++1-704-865-7444
📠 ++1-704-865-7781
✉ info@us.stabilus.com

www.stabilus.com

STABILUS

STABILUS macht Technik
komfortabel

STABILUS technology
gives comfort

STABILUS rend
la technique confortable