Safety switches

XCS range

Catalogue



Simply easy!™

> Appropriate solutions

The latest operating safety standards propose new risk management methods right from the design stage, making use of concepts such as Safety Integrity Levels (SIL) and Performance Levels (PL).

Schneider Electric safety solutions enable you to optimize the cost of your installations according to the level of safety required, while maximizing interoperability.

3 pre-defined safety levels

PL=d (category 3) / SIL 2



Architecture 2

Several XCSLF in series + XPSUAF + 2 LC1D + 1 XB4 start + XPSVNE (for zero speed detection)
For more than one XCSLF connected in series, the safety level can even be reduced to PLc (see fault masking restrictions in ISO/TR 24119)

Used with Schneider Electric safety relays, safety controllers or safety PLCs and TeSys motor starter solutions, XCS safety switches offer levels of access protection up to PLe, category 4, SIL3, according to standards requirements in force EN ISO 13849-1 and EN/IEC 62061.

PL=b (category 1) / SIL 1

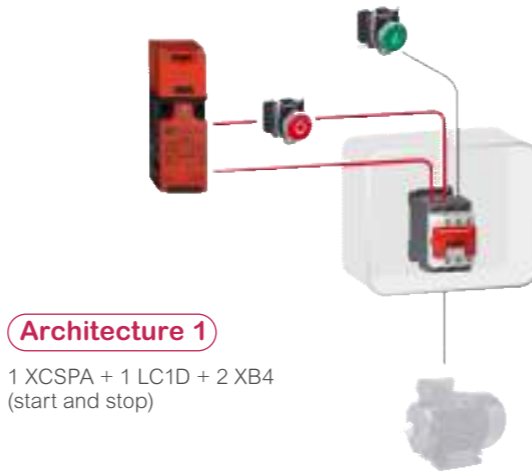

Architecture 1

1 XCSPA + 1 LC1D + 2 XB4 (start and stop)



Architecture 3

Several XCSDM in series with 1 XPSUAF + ABL8 + CAD32 (or LC1D)
For more than one XCSDM connected in series, the safety level can even be reduced to PLc (see fault masking restrictions in ISO/TR 24119)

PL=e (category 4) / SIL 3

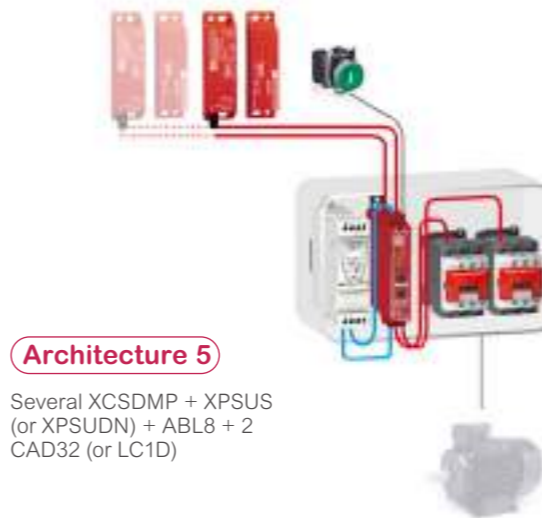

Architecture 5

Several XCSDMP + XPSUS (or XPSUDN) + ABL8 + 2 CAD32 (or LC1D)

Architecture 4

1 XCSRC●0M12 + 1 XCSA + 1 XCSLF + 1 XCSM + XPSMCM + 2 LC1D

Architecture 7

Several XCSRC●2M12 + ABL8 + 2 LC1D

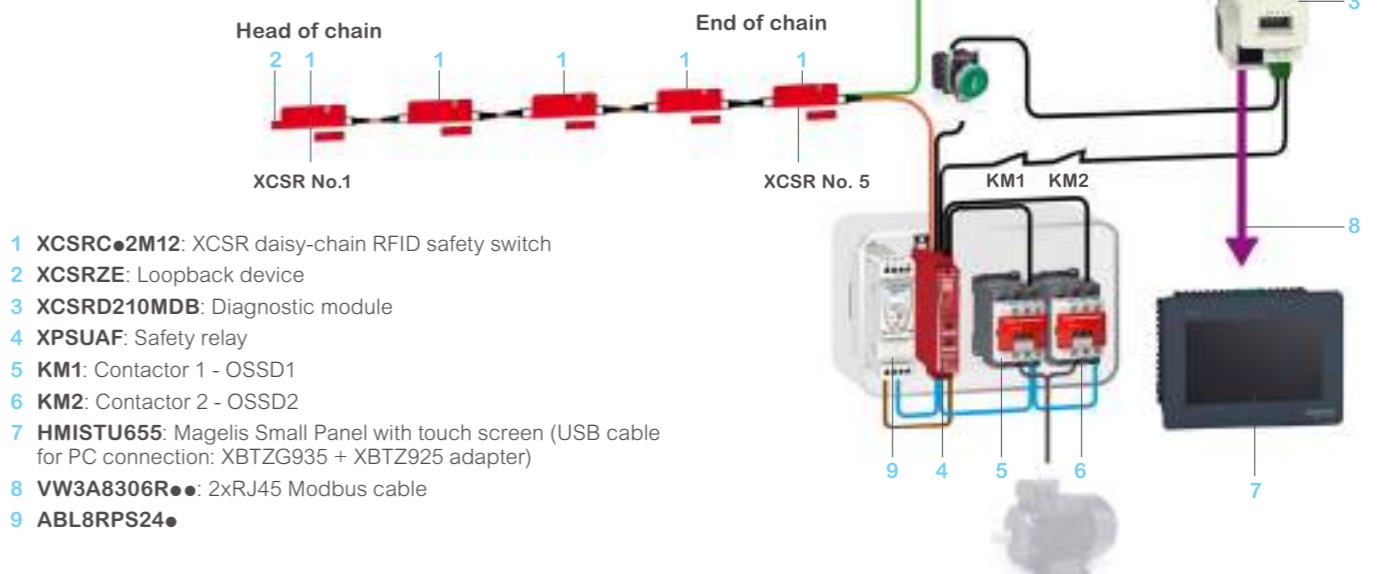

- 1 XCSRC●2M12: XCSR daisy-chain RFID safety switch
- 2 XCSRZE: Loopback device
- 3 XCSR210MDB: Diagnostic module
- 4 XPSUAF: Safety relay
- 5 KM1: Contactor 1 - OSSD1
- 6 KM2: Contactor 2 - OSSD2
- 7 HMISTU655: Magelis Small Panel with touch screen (USB cable for PC connection: XBTZG935 + XBTZ925 adapter)
- 8 VW3A8306R●●: 2xRJ45 Modbus cable
- 9 ABL8RPS24●●

> XCS safety switches guide your choice

Whatever your activity sector, your type of machine or your automated function, Telemecanique Sensors offers you a complete range of safety switches to meet your protection requirements for functional safety.

Adaptable to your environment

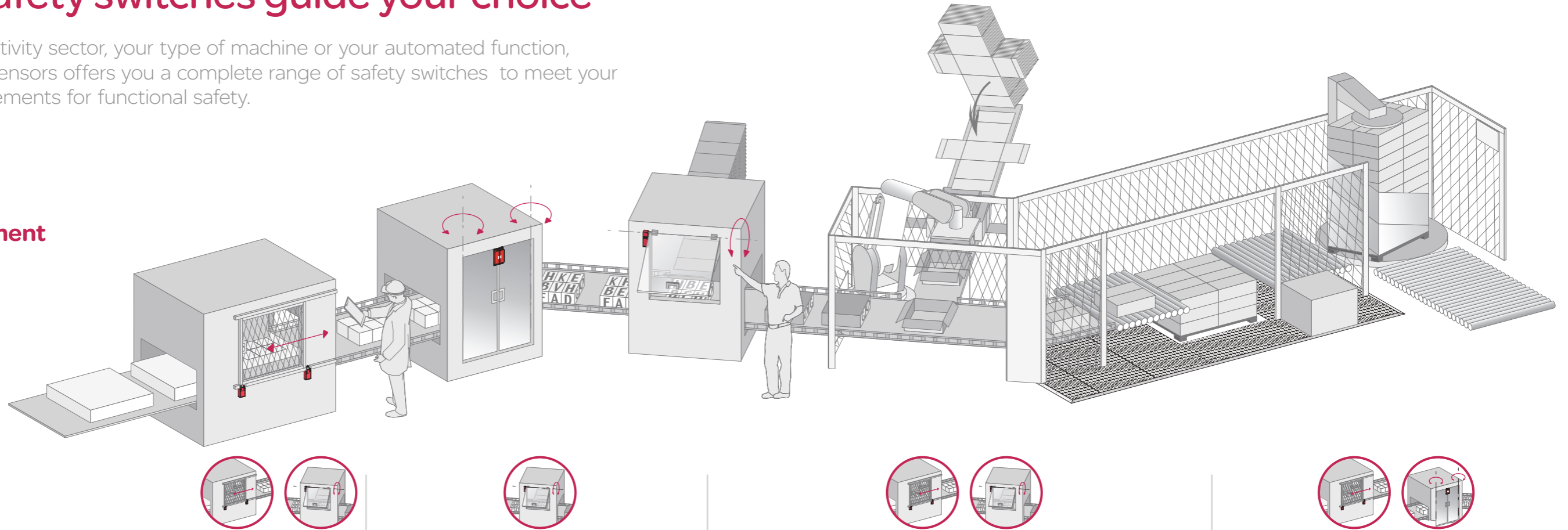

Actuation mode		Mechanical: 5 different actuator heads	Lever or hinge-operated	Mechanical using separate key actuators	Mechanical and interlock by separate key manual unlocking	Mechanical and interlocking using separate key, Solenoid locking/unlocking	Contact-free		
Non-defeatibility	According to ISO 14119	Actuator protected against manual operation	Mechanical direct connection	Without solenoid Using special specific key		With solenoid	Using RFID unique code High level of coding	Using coded magnetic key Low level of coding	
Product type and preferred machine architecture by safety level (PL/SIL)	PL=b (category 1) / SIL1	Architecture 1			-		-	-	
	PL=d (category 3) / SIL2	Architecture 2			-		-	Architecture 3	
	PL=e (category 4) / SIL3	Architecture 4			-		Architecture 4, 6 or 7	Architecture 5	
Normal environment		XCSP: Plastic body, 3 contacts secured mounting adjustment and cabling access using special screws (XCSM and XCSD also)	XCSPL: Stainless steel lever, up to 3 contacts	XCSPR - XCSTR: Stainless steel spindle operator, for direct axis control, up to 3 contacts	XCSPA, XCSTA: Compact plastic body, up to 3 contacts XCSMP: Miniature key switch with cable output, up to 3 contacts	-	XCSTLE: Reinforced plastic body, F _{2N} = 1100N slim dimensions, up to 6 contacts for inertia machines XCSTE: Plastic body, rectangular shape, 3 contacts F _{2N} =500N, for small machines with inertia	-	
Harsh environment		XCSM: Metal miniature, up to 4 contacts XCSD: Metal compact, 3 contacts for covers and gates	-	-	XCSA: Metal body, 3 contacts for protection against accidental impact for controlling heavy doors	XCSB XCSC: Metal body, 3 contacts, release using pushbutton or key	XCSTLF: Slim dimensions, metal body, F _{2N} =2300 N. Up to 6 contacts, reinforced locking for inertia machines in harsh environments XCSE: Metal body, rectangular shape, 5 contacts, F _{2N} =2000N, for inertia machines	XCSR: Thermo-plastic body, 3 versions (standalone, daisy-chain or single models for point-to-point connection) Suitable for low inertia machines with doors, covers or guards with imprecise alignment. Ideal for dust and liquid environments which may be exposed to impact and vibrations.	XCSDMP - XCSDMC compact, XCSDMR cylindrical, Various formats, ideal for dusty environments. Suitable for low inertia machines with doors, covers or guards with imprecise alignment
Safety controllers & relay modules		XPSUAF, XPSUAK, XPSUDN, XPSUAT, XPSUS, XPSMCM (1) (2)				-	Not necessary for standalone models. XPSUAF, XPSUAK, XPSUAT, XPSUDN, XPSUS, XPSMCM (1)(2) for daisy-chain or single models.	XPSUAK, XPSUDN, XPSUAT, XPSUS, XPSMCM (1)(2)	

(1) In combination with an appropriate and correctly connected safety control unit. Refer to the relevant safety standards and product features to determine the maximum safety level achievable for the application.

(2) Complete references and other XPS safety control units are available on www.schneider-electric.com

Safety detection solutions

XCS safety switches

Switch type		XCS safety limit switches		
Applications		Protection of operators by stopping the machine when the gate is opened. All machines with quick rundown time.		
Design		Miniature format	Compact format	
		Pre-cabled	With 1 cable entry	
				
Case		Metal	Plastic	Metal
Features		-		
Conformity to standards		EN/IEC 60947-5-1, EN/ISO 13849-1, EN/IEC 62061, UL 508, CSA C22-2 no. 14		
Products		EN/IEC 60204-1, EN/ISO 14119		
Machine assemblies				
Product certifications		UL, CSA, CCC, EAC		
Dimensions (w x h x d) in mm		Switch	Centers	
		Fixings		
		30 x 50 x 16	31 x 34 x 89	
		20	20/22	
Head		Plunger or rotary head Head adjustable in 15° steps through 360° Linear (plunger) or rotary (lever) actuation.		
Contact blocks		NC contacts with positive opening operation		
		2 NC + 1 NO break before make, slow break 2 NC + 1 NO and 2 NC + 2 NO snap action	XCSD: 2 NC + 1 NO break before make, slow break or snap action XCSP: 2 NC + 1 NO snap action	
Degree of protection		IP 66, IP 67 and IP 68	IP 66 and IP 67	
Ambient air temperature		For operation -25...+70 °C		
Connection		Screw terminals (cable entry via cable gland)	Tapped entry for Pg 13.5, ISO M20 cable gland or tapped 1/2" NPT	
		Pre-cabled	-	
		L = 1, 2 or 5 m	-	
Type reference		XCSM	XCSP	XCSD
Pages		26	30	

XCS lever or spindle-operated safety switches		
Protection of operators by stopping the machine when the operating lever (attached to hinged machine guard) is displaced by 5°. All light industrial machines fitted with hinged or rotary protective covers with small opening radius.		Protection of operators by stopping the machine when the guard hinge rotates through 5°. All light industrial machines fitted with hinged access doors.
Compact format		
With 1 or 2 cable entries		
		
Plastic, double insulated		
2 types of lever: straight or elbowed (flush with rear of switch) 3 lever positions: to left, center or to right		2 types of spindle: length 30 mm or 80 mm
EN/IEC 60947-5-1, EN/ISO 13849-1, EN/IEC 62061, UL 508, CSA C22-2 no.14, JIS C4520		
EN/IEC 60204-1, EN/ISO 14119		
UL, CSA, CCC, EAC		
30 x 87.5 x 30		30 x 96 x 30
20/22		20/22
20/22		20/22 or 40.3
Turret head: 4 positions Rotary actuation (lever)		Turret head: 4 positions Rotary actuation (spindle)
Slow break safety contacts with positive opening operation NC contacts open when lever or spindle displaced by more than 5°		
1 NC + 1 NO break before make 2 NC 1 NC + 2 NO break before make 2 NC + 1 NO break before make	1 NC + 1 NO break before make 2 NC 1 NC + 2 NO break before make 2 NC + 1 NO break before make	1 NC + 2 NO break before make 2 NC + 1 NO break before make 3 NC
IP 67		
-25...+70 °C		
1 tapped entry for Pg 11, ISO M16 cable gland or tapped 1/2" NPT	1 tapped entry for Pg 11, ISO M16 cable gland or tapped 1/2" NPT	2 tapped entries for Pg 11, ISO M16 cable gland or tapped 1/2" NPT
-	-	-
XCSP	XCSPR	XCSTR
36		

Safety detection solutions

XCS safety switches

Switch type	XCS key-operated safety switches		
Applications	Protection of operators by stopping the machine when the actuating key (attached to machine guard) is withdrawn from the head of the switch. All light industrial machines with quick rundown time (1).		
Design	Miniature format	Compact format	
	Pre-cabled	With 1 or 2 cable entries	



Case	Plastic			
Features	Without locking of actuating key.	Without locking of actuating key. Optional accessory: guard retaining device.		
Conformity to standards	Products Machine assemblies	EN/IEC 60947-5-1, EN/ISO 13849-1, EN/IEC 62061, UL 508, CSA C22-2 no. 14 EN/IEC 60204-1, EN/ISO 14119		
Product certifications		cULus UL, CSA, CCC, EAC		
Dimensions (w x h x d) in mm	Switch	30 x 87 x 15	30 x 93.5 x 30	52 x 114.5 x 30
	Fixings	Centers: 20/22	Centers: 20/22	Centers: 20/22 or 40.3
Head		Fixed head: 2 positions for insertion of actuating key.	Turret head: 8 positions for insertion of actuating key.	
Contact blocks		Safety contacts actuated by the actuating key. Slow break and NC positive opening operation.		
		1 NC + 1 NO break before make 2 NC 2 NC + 1 NO break before make 3 NC	1 NC + 1 NO slow break contacts, break before make or make before break, or snap action 2 NC slow break or snap action 2 NC + 1 NO slow break contacts, break before make, or snap action 1 NC + 2 NO slow break contacts, break before make, or snap action	1 NC + 2 NO break before make 2 NC + 1 NO break before make 3 NC
Degree of protection		IP 67		
Ambient air temperature	For operation	-25...+70 °C		
Connection	Screw terminals (cable entry via cable gland)	Tapped entry for Pg 11, ISO M16 cable gland or tapped 1/2" NPT		
	Pre-cabled	L = 2, 5 or 10 m	-	-
Type reference		XCSPMP	XCSPA	XCSTA
Pages		42	46	

(1) Machine stopping time less than time taken for operator to access hazardous zone.

XCS key-operated safety switches		
All heavy industrial machines with quick rundown time (1)		
Industrial format with or without locking		
With 1 cable entry, without locking	With 1 cable entry and manual locking/unlocking	



Case	Metal		
Features	Without locking of actuating key.	Manual locking and unlocking of actuating key by pushbutton (can be mounted on left or right-hand side of switch head).	Manual locking and unlocking of actuating key by key-operated lock (can be mounted on left or right-hand side of switch head).
Conformity to standards	Products Machine assemblies	EN/IEC 60947-5-1, EN/ISO 13849-1, EN/IEC 62061, UL 508, CSA C22-2 no. 14 EN/IEC 60204-1, EN/ISO 14119	
Product certifications		UL, CSA, CCC, EAC	
Dimensions (w x h x d) in mm	Switch	40 x 113.5 x 44	52 x 113.5 x 44
	Fixings	30 x 60	30 x 60
Head		Turret head: 8 positions for insertion of actuating key.	Turret head: 8 positions for insertion of actuating key.
Contact blocks		Safety contacts actuated by the actuating key. Slow break and NC positive opening operation.	
		1 NC + 2 NO break before make 2 NC + 1 NO break before make 3 NC	1 NC + 2 NO break before make 2 NC + 1 NO break before make 3 NC
Degree of protection		IP 67	
Ambient air temperature	For operation	-25...+70 °C	
Connection	Screw clamp terminals. Tapped entry for Pg 13.5, ISO M20 cable gland or tapped 1/2" NPT	Screw clamp terminals. Tapped entry for Pg 13.5 cable gland, ISO M20 or tapped 1/2" NPT.	
	Pre-cabled	-	-
Type reference		XCSEA	XCSB XCSA
Pages		50	

Safety detection solutions

XCS safety switches

Switch type	XCS key-operated safety switches, locking and unlocking by solenoid	
Applications	Protection of operators by stopping the machine when the actuating key (attached to machine guard) is withdrawn from the head of the switch. All industrial machines with long rundown time (1)	
Design	Slim format	
	With 3 cable entries	With 3 cable entries



Case	Plastic	Metal
Features	Locking and unlocking of actuating key using a solenoid (either on energization or on de-energization). Manual unlocking (auxiliary release using special tool) of actuating key in abnormal conditions.	Locking and unlocking of actuating key by solenoid (either on energization or on de-energization). Manual unlocking (auxiliary release using key lock) of actuating key in abnormal conditions. 1 Emergency release mushroom head pushbutton (only for XCSLF●●●●●4●● and XCSLF●●●●●6●●).
Conformity to standards	EN/IEC 60947-5-1, EN/ISO 13849-1, EN/IEC 62061, UL 508 and CSA C22-2 no. 14	
Products	EN/IEC 60204-1, EN/ISO 14119	
Machine assemblies	UL, CSA, CCC, EAC	
Product certifications	UL, CSA, CCC, EAC	
Dimensions (w x h x d or Ø) in mm	Switch 51 x 205 x 43.5	Fixings 30 x 153.3
Centers	Turret head: 8 positions for insertion of actuating key.	
Head	Resistance to forcible withdrawal of the actuator	
	F_{1max} 1400 N	F_{2h} 3000 N
	1100 N	2300 N
Contact blocks or outputs	Main safety contacts actuated by the actuating key; auxiliary contacts actuated by solenoid. Contact states given with key inserted and solenoid not energized. Slow break and NC positive opening operation	
Main contacts	1 NC + 1 NO break before make 2 NC 1 NC + 2 NO break before make 2 NC + 1 NO break before make 3 NC	
Auxiliary contacts	1 NC + 1 NO break before make 2 NC 1 NC + 2 NO break before make 2 NC + 1 NO break before make 3 NC	
Degree of protection	IP 66/IP 67	
Ambient air temperature	For operation -25...+60 °C	For storage -40...+70 °C
Connection	Terminals Spring terminals, 3 cable entries. Tapped entry for ISO M20 cable gland or tapped 1/2" NPT.	Connector M23 (18 + 1 PE)
Type reference	XCSLE	XCSLF
Pages	54	54

(1) Machine stopping time greater than time taken for operator to access hazardous zone.

Switch type	XCS key-operated safety switches, locking and unlocking by solenoid (continued)	
Applications	Protection of operators by stopping the machine when the actuating key (attached to machine guard) is withdrawn from the head of the switch. All industrial machines with long rundown time (1)	
Design	Rectangular	
	-	With 2 cable entries



Case	Plastic, double insulated	Metal
Features	Locking and unlocking of actuator by solenoid (either on de-energization or on energization). Manual unlocking (auxiliary release using special tool) of actuating key in abnormal conditions.	Locking and unlocking of actuating key by solenoid (either on energization or on de-energization). Manual unlocking (auxiliary release using key lock) of actuating key in abnormal conditions.
Conformity to standards	EN/IEC 60947-5-1, EN/ISO 13849-1, UL 508, CSA C22-2 no. 14, EN/IEC 62061, EN/IEC 60947-1	
Products	EN/IEC 60204-1, EN/ISO 14119	
Machine assemblies	UL, CSA, CCC, EAC	UL, CSA, CCC, EAC
Product certifications	UL, CSA, CCC, EAC	UL, CSA, CCC, EAC
Dimensions (w x h x d or Ø) in mm	110 x 93.5 x 33	98 x 146 x 44
Centers	30 x 153.3	88 x 95
Head	Turret head: 8 positions for insertion of actuating key	
Resistance to forcible withdrawal of the actuator	650 N	2600 N
	500 N	2000 N
Contact blocks or outputs	Main safety contacts actuated by the actuating key; auxiliary contacts actuated by solenoid. Slow break and NC positive opening operation	
Main contacts	1 NC + 1 NO break before make 1 NC + 1 NO make before break 2 NC	1 NC + 2 NO break before make 2 NC + 1 NO break before make 3 NC
Auxiliary contacts	1 NC	1 NC + 1 NO 2 NC
Degree of protection	IP 67	
Ambient air temperature	-25...+60 °C	-25...+40 °C
	-40...+70 °C	-40...+70 °C
Connection	Tapped entry for Pg 11 ISO M16 cable gland or tapped 1/2" NPT	Screw clamp terminals. 2 tapped entries for Pg 13.5 ISO M20 cable gland or tapped 1/2" NPT.
Type reference	XCSLE	XCSLF
Pages	70	70

Safety detection solutions

XCS safety switches

Switch type	XCSR contactless RFID safety switches
Applications	Highly tamper-proof protection of operators by stopping the machine when the gate is opened (transfer lines, assembly lines, automated equipment, machine tools, etc.). All light industrial machines fitted with access gates with imprecise guidance and/or subjected to frequent washing, shocks and vibrations. This Safety sensor is suitable for machine with low inertia.
Design	Rectangular format Unique pairing or 2 new pairings possible



Case	Thermoplastic housing (Valox TM)		
Features	Contactless system composed of a microprocessor-controlled switch and a transponder factory-paired with a unique code. Multiposition sensor transponder.		
Assured operating sensing distance (Sao)	15 mm		
Assured release distance (Sar)	35 mm		
Type of switch	Standalone RFID switch	Daisy-chain RFID switch for direct series connection	Single RFID switch for point-to-point connection
Operating mode	Possible functioning without association with a safety control unit (Integrated External Device Monitoring (EDM) and Start/Restart function)	Functioning in combination with a safety control unit PL=e/Cat4 - SIL 3	
Conformity to standards	Products EN/IEC 60947-5-2, EN/IEC 60947-5-3, UL 508, CSA C22.2 SIL 3 (IEC 61508), SILCL 3 (IEC 62061), PL=Cat. 4 (EN ISO 13849-1)		
Machine assemblies	EN/IEC 60204-1, EN/ISO 14119		
RFID protocol	Based on ISO 15693		
Product certifications	CE, cULus, TÜV, FCC, EAC, IC, RCM, E2, ECOLAB		
Dimensions (w x h x d or Ø) in mm	Switch 30 x 108.3 x 15	Transponder 30 x 118.6 x 5	30 x 108.3 x 15
Fixings	Centers 50 x 15 x 15		
	Reader 74...78		
	Transponder 30...34		
Contact blocks or outputs	Safety output 2 OSSDs (Safety outputs PNP NO). OSSDs are in the ON state when the gate is closed Maximum current 400mA Maximum current 200 mA		
Contact states given in presence of magnet	-		
Degree of protection	- IP 65, IP 66, IP 67 IP 69K		
Ambient air temperature	For operation -25...+70 °C For storage -40...+85 °C		
Connection	Pre-cabled Connector Conforming to EN/IEC 60947-5-2-A3 and EN/IEC 61076		
	1 M12 8-pin connector (A coding)	2 M12 5-pin connector (A coding)	1 M12 5-pin connector (A coding)
Type reference	XCSRC•1•M12	XCSRC•2M12	XCSRC•0M12
Pages	86		

XCS safety coded magnetic safety switches for detection without contact		
Protection of operators by stopping the machine when the gate is opened All light industrial machines fitted with access gates with imprecise guidance and/or subjected to frequent washing This Safety sensor is suitable for machine with low inertia.		
Miniature rectangular format	Compact rectangular format	Cylindrical format
Pre-cabled or M8 connector on flying lead	Pre-cabled or M12 connector on flying lead	



Case	Plastic	
Features	3 approach directions	
Assured operating sensing distance (Sao)	1 approach direction	
Assured release distance (Sar)	5 mm	8 mm
Type of switch	15 mm	20 mm
Operating mode	-	
Conformity to standards	EN/IEC 60947-5-1, EN/ISO 13849-1, EN/IEC 62061, UL 508 and CSA C22-2 no. 14	
Products	EN/IEC 60204-1, EN/ISO 14119	
Machine assemblies	-	
RFID protocol	UL, CSA, EAC, ECOLAB	
Dimensions (w x h x d or Ø) in mm	16 x 51 x 7	25 x 88 x 13
Fixings	Centers Ø 30, L 38.5	
	16	78
	-	
Contact blocks or outputs	1 NC + 1 NO staggered 2 NC staggered Independent Reed-type contacts operated by coded magnet.	
Contact states given in presence of magnet	1 NC + 1 NO staggered 2 NC staggered	1 NC + 1 NO staggered 2 NC staggered
Degree of protection	To be used with safety control units. IP 66 and IP 67 for pre-cabled version, IP 67 for connector on flying lead version	
Ambient air temperature	-25...+85 °C	
Connection	L = 2, 5 or 10 m M8, on 0.15 m flying lead	
	M12, on 0.15 m flying lead	-
Type reference	XCSDMC	XCSDMP
Pages	100	

Refer to standards
EN/ISO 12100 and EN/ISO 14119
IEC/ISO 13852 and EN/IEC 60204-1

Telemecanique Sensors XCS safety detection solutions conform to EN/ISO 12100 and EN/ISO 14119 standards regarding potentially hazardous machine functions. They meet more specifically the following requirements:

- Removable or movable protective guards must be used in conjunction with locking or interlocking devices,
- For high inertia machines (i.e. with long rundown time), an interlocking device must be used. With a long rundown time, the rundown time is greater than the time it takes for a person to reach the hazardous zone. The interlocking device helps ensure that the guard remains locked until the potentially hazardous movement has stopped.

Safety interlock switches

As required by EN/ISO 12100 and EN/ISO 14119, safety interlock switches which are specifically designed for machine guarding applications provide an ideal solution for the locking or interlocking of movable guards associated with industrial machinery. They also meet the requirements of IEC/ISO 13852 and EN/IEC 60204-1.

They contribute to the protection of operators working on potentially hazardous machines by breaking the start control circuit of the machine when a protective guard is opened or removed, using **positive opening operation contacts**, thus stopping the hazardous movement of the machine.

Removal/opening of the guard (after the hazardous movement has stopped) can either be:

- at the time the machine is switched off for low inertia machines (machines where the rundown time is less than the time it takes for the operator to access the hazardous zone), or
- delayed for high inertia machines (machines where the rundown time is greater than the time it takes for the operator to access the hazardous zone).

Control circuit categories

If used with a Schneider Electric safety control unit, the safety interlock switch enables designers to achieve PL=e, category 4 control systems with reference to EN/ISO 13849-1 and SIL CL3 with conformity to EN/IEC 62061. When used on their own or combined with another switch, they can achieve up to category 1, 2 or 3 control circuits (except for RFID XCSR standalone models which can reach PLe-Cat. 4/SIL3 without safety control unit).

Safety related parts of control systems shall be developed taking into account the results of an appropriate Risk Assessment.

Safety of personnel

The start command for the machine can only be initiated following correct operation of the safety interlock switch.

On its release, the NC safety contacts are opened by **positive action** or, for coded magnetic switches, change state (**this should be monitored using a Schneider Electric safety control unit**). RFID XCSR safety switches have 2 OSSDs (Output Signal Switching Devices) which are NC when the guard is closed.

Safety of operation

The safety interlock switches incorporate slow break or snap action contacts with **positive opening operation** (except for coded magnetic switches where this is not possible). For mechanical safety interlock switches, on closing of the guard the actuating key fitted to it enters the head of the switch, operates the multiple interlock device and closes the NC contacts. For coded magnetic switches, the presence of the magnet causes the contacts to change state. For RFID XCSR safety switches, the 2 OSSDs change from ON to OFF state when the guard is being opened.

Safety in use

In order to compensate for mechanical clearance, vibration, etc., all safety interlock switches are designed to accept a few millimeters of misalignment between the actuating key and the switch, or between the magnet and the sensor part for coded magnetic switches, or between the transponder and the reader for RFID XCSR safety switches.

Design to minimize defeat

Mechanically, magnetically or RFID-actuated safety interlock switches are designed to be operated by specific actuating keys so that they cannot be defeated in a simple manner using common tools (rods, metal plates, simple magnets, etc.). When loosening the fixing screws for re-orientation of the turret head on safety interlock switches, the head itself remains attached to the switch body and the contact states remain unchanged.

All safety interlock switches and safety limit switches are designed to avoid any adjustments in the head setting, removal of the actuating key or access to the safety contacts without using the appropriate tool.

There are various methods for obtaining a higher level of tamperproofing, for example:

- using a cage device to help prevent the insertion of a spare actuating key or magnet, or any other foreign body
- fixing the actuating key or coded magnet to the guard by means that make it very difficult to remove (riveting or welding)
- using RFID unique coding XCSR safety switches

Metal key-operated safety switches - Without solenoid

Without locking of actuating key



XCSA without manual unlocking

Metal case key-operated switches for use on machines **with low inertia** and operating in **normal conditions** (no vibration or shock and guard mounted vertically, without risk of rebound on closing), thus helping to eliminate unintentional opening of the guard.

With locking of actuating key and manual unlocking



XCSB with pushbutton



XCSC with actuating key

Metal case key-operated switches for use on heavy machines **with low inertia** and operating in **arduous conditions** (shock or vibration), whereby the guard could open unintentionally. A key-operated lock or a pushbutton enables positive locking of the guard and its subsequent unlocking.

Metal safety interlock switches - With solenoid

With interlocking of actuating key by solenoid



XCSLF slim (metal case)

Metal case safety interlock switches for use on machines **with high inertia** with controlled opening of the protective guard. Locking of the moving guard can either be on de-energization or energization of the solenoid.

Auxiliary release: A key-operated lock enables manual unlocking of the guard from outside the safeguarded area in the event of an interlocking circuit malfunction, and also provides extra safety for maintenance personnel likely to be working on the machine. The switches incorporate 2 LEDs: one indicating guard "open" and the other, guard "closed and locked" (XCSLF/XCSE).

Emergency release with mushroom head pushbutton



XCSLF with mushroom button

Safety interlock switches are available with a mushroom head pushbutton mounted on the rear of the switch for unlocking the machine guard from inside the safeguarded area.

This manual unlocking using the mushroom head pushbutton for emergency release is useful in the following cases:

- while the machine or a group of machines is undergoing maintenance, enabling operation at reduced speed
- while stopped with the guard(s) closed

The safety of maintenance personnel is thus improved in the event of:

- a power outage
- an interlocking circuit malfunction
- personnel finding themselves in a hazardous situation

Unlocking using the emergency release mushroom head pushbutton takes priority over any other action. It therefore enables a person to leave the zone if the need arises.

This function is reinitialized by turning (with or without a key) the emergency release mushroom head.

Plastic key-operated safety switches - Without solenoid

Without locking of actuating key - Without solenoid



XCSMP XCSPA XCSTA

Plastic case safety interlock switches for use on light machines **with low inertia** and operating in **normal conditions**.

For use in arduous conditions (shock or vibration, guard not vertical or risk of rebound on closing) where the guard could open unintentionally, a **guard retaining device (XCSPA or XCSTA)** is available as an accessory.

Plastic safety interlock switches - With solenoid

With interlocking of actuating key by solenoid



XCSLE slim (plastic case)

Plastic case safety interlock switches for use on machines **with high inertia** with controlled opening of the protective guard.

Locking of the moving guard can either be on de-energization or energization of the solenoid.

Auxiliary release: A special tool enables manual unlocking of the guard from outside the safeguarded area in the event of an interlocking circuit malfunction, and also provides extra safety for maintenance personnel likely to be working on the machine.

The switches incorporate 2 LEDs: one indicating guard "open" and the other, guard "closed and locked" (XCSLE).

Safety detection solutions

Lever or spindle-operated safety switches, safety limit switches, coded magnetic switches and contactless RFID safety switches

Rotary lever and spindle-operated switches for hinged or cover guards

With head for rotary movement (lever or spindle)



XCSTR
with spindle

XCSPL
with lever

Plastic case safety interlock switches with straight or elbowed operating lever or spindle operator. Specifically designed for small industrial machines with low inertia fitted with small **hinged doors, covers or protective guards**. They help protect the operator by immediately stopping the hazardous movement of the machine as soon as the rotary lever or spindle displacement reaches an angle of 5°.

Safety limit switches

With head for linear movement (plunger) or rotary movement (lever)



XCSD for rotary
movement

XCSM for linear
movement

Metal or plastic case limit switches. For use on machines with low inertia and also on machines with high inertia, when used in conjunction with key-operated safety interlock switches with solenoid for monitoring access doors and/or guards. When used on their own, they are always installed in "positive mode" or combined in pairs, with one switch being in "positive mode" and the other in "negative mode".

Coded magnetic switches

With an associated coded magnet



XCSDMC,
compact format

XCSDMP,
standard format



XCSDMR,
cylindrical format

Plastic case guard switches for use on machines with low inertia. Specifically designed for industrial machines fitted with **doors, covers or guards with imprecise guiding**. They are ideally suited for machines subjected to frequent washing or liquid spray. They help protect the operator by immediately stopping any hazardous movement, as soon as the distance between the switch and its magnet is greater than 8 or 5 mm, depending on the switch model.

Contactless RFID safety switches

Operated by a digital code



XCSR contactless RFID safety
switches (model for series
connection (daisy-chain))

Plastic case switch and transponder for use on machines with low inertia. Specifically designed for industrial machines fitted with **doors, covers or guards with imprecise guiding**. They are ideally suited for **machines subjected to frequent washing or liquid spray, and exposed to shocks and vibrations**. Contactless system composed of a microprocessor-controlled switch and a transponder.

The reader and the transponder are factory-paired so as to load into the transponder a unique code shared with the reader. This saved digital code is the unique "key" accepted by the paired reader. **This type of switch is thus difficult to tamper with.**

As long as the transponder is in the reader detection zone (<15 mm), the machine will run normally. When the transponder goes outside the field generated by the reader, the reader stops the machine, indicating that the safety guard is open.

Actuating keys

The actuating keys are common to all safety interlock switches: metal case XCSLF, XCSE, XCSA, XCSB, XCSC and plastic case XCSLE

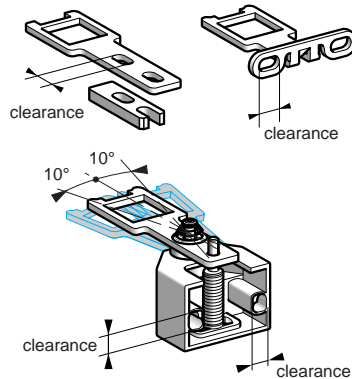

Their oblong fixing holes enable simple adjustment when mounting on moving guards.

A pivoting actuating key (both horizontally and vertically) is available when using safety interlock switches in conjunction with hinged guards or guards with imprecise guiding.

Straight actuating keys are supplied with an adapter shank for simple replacement of legacy XCKJ or XCSL5/7 safety interlock switches by an XCSLF/LE switch, without the need to drill additional fixing holes for the switch or the actuating key.

Turret head

All metal case safety interlock switches are fitted with a square turret head which can be rotated through 360° in 90° steps

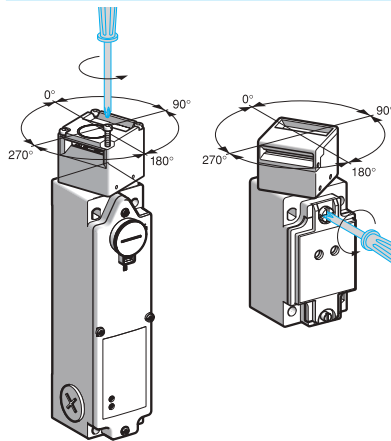

8 directions of actuation are possible for the actuating key:

- 4 in the horizontal plane
- 4 from above the switch (4 alternative positions of the actuating key slot, depending on the orientation of the head).

When loosening the fixing screw(s) for re-orientation of the operating head, the head itself remains attached to the body and the contact states remain unchanged.

Safety (or main) contacts

Metal case safety interlock switches incorporate a 2-pole (XCSLF) or a 3-pole (XCSLF, XCSE, XCSA, XCSB, XCSC) contact block with NC contacts with positive opening operation, which is actuated by insertion or withdrawal of the actuating key attached to the guard.

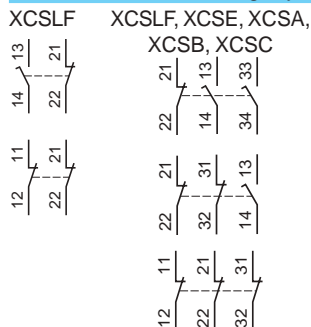

Withdrawal of the actuating key opens the NC safety contact(s), even in the event of the contact sticking or welding.

The 3-pole contact block enables redundant safety circuits to be established (for example: NC + NC or NC + NO) and also to provide signaling (for example: PLC, illuminated beacon, etc.).

Auxiliary contacts

Safety interlocks with solenoid (XCSLF and XCSE) have 2 (XCSLF, XCSE) or 3 auxiliary contacts (XCSLF) for monitoring the solenoid position (locking monitoring) - NC contacts with positive opening operation

LED indicators

An orange LED (optional for XCSA, XCSB and XCSC key-operated switches, standard for XCSLF and XCSE safety interlock switches) indicates the position of the machine guard:



LED illuminated: actuating key not inserted in head of switch, NC contact(s) open, guard open.



LED not illuminated: actuating key inserted in head of switch, NC contact(s) closed, guard closed.

A green LED (incorporated on XCSLF, XCSLE, XCSE and XCSTE safety interlock switches) indicates the locking of the machine guard:



LED not illuminated: actuating key not inserted in head of switch. The machine cannot be operated.



LED illuminated: actuating key inserted in head of switch and actuating key locked. The machine is either ready for starting, running or decelerating to a standstill.

Note: LEDs should be wired in accordance with the schematics indicated in the instruction sheet or in the catalog pages.

Safety detection solutions

Metal case key-operated safety interlock switches

Manual locking/unlocking by pushbutton or key-operated lock

The pushbutton or key-operated lock fitted to XCSB and XCSC key-operated switches allows manual locking/unlocking of the machine guard

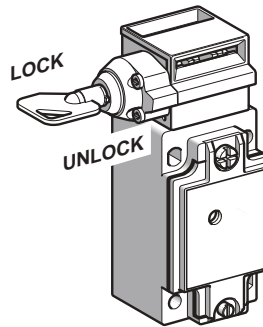

The use of pushbutton or key is not necessary for normal operation of the safety interlock switch (XCSA). For XCSB and XCSC key-operated switches, when the machine guard is locked (key in "LOCK" position), the resistance to forcible withdrawal of the actuating key fitted to the guard is $F_{Zn} = 1150 \text{ N}$. The key is removable from the locking device in the "LOCK" position.

Locking/unlocking by solenoid

XCSLF and XCSE safety interlock switches incorporate a solenoid for locking/unlocking of the machine guard

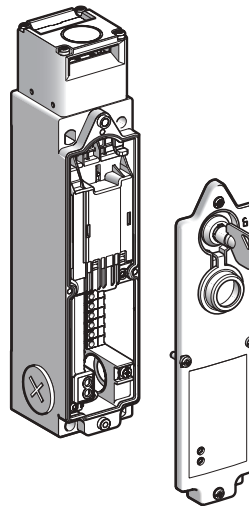

With the machine guard closed and locked, the resistance to forcible withdrawal of the actuating key fitted to the guard is $F_{Zn} = 2300 \text{ N}$ (XCSLF) and $F_{Zn} = 2000 \text{ N}$ (XCSE) (according to EN/ISO 14119 - $F_{Zn} = F_{1max}/1.3$).

In addition to the 2-pole (XCSLF) or 3-pole contacts (XCSLF and XCSE), positively operated by the actuating key fitted to the guard, XCSLF safety interlock switches incorporate **NC + NO or 2 NC or 1 NC + 2 NO or 2 NC + 1NO or 3NC auxiliary contact blocks mechanically linked to the solenoid (NC + NO or 2 NC for XCSE)**.

The NC contact(s) are for use in the safety circuit of the machine and the NO contact for signaling the status of the solenoid.

Key-operated lock (auxiliary release)

XCSLF and XCSE safety interlock switches are fitted with a key-operated lock allowing unlocking of the machine guard from outside the safeguarded area (for use by authorized personnel only)

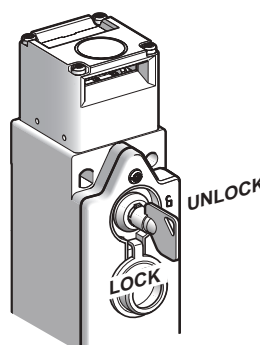

Manual unlocking of the guard using the key-operated lock is useful in the following cases:

- while the machine is undergoing maintenance (with the key turned to the "UNLOCK" position and then removed, the level of protection is higher for helping to prevent an accidental machine start. Safety for maintenance personnel is thus improved):
- in the event of a power outage
- in the event of an interlocking circuit malfunction (interlocked condition maintained: positive safety).

The electrical supply providing unlocking via the solenoid always takes priority over manual unlocking using the key-operated lock.

The lock fitted to standard safety interlock switches has key withdrawal from the "LOCK" and "UNLOCK" positions.

Actuating keys

The actuating keys are common to plastic XCSTE, XCSPA and XCSTA key-operated switches (except for XCSMP, see page 42)

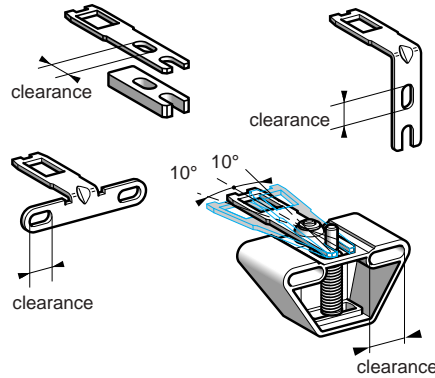

Their oblong fixing holes enable simple adjustment when mounting on moving guards.

A pivoting actuating key (both horizontally and vertically) is available when using safety interlock switches in conjunction with hinged guards or guards with imprecise guiding.

Straight actuating keys are supplied with an adapter shank for simple replacement of a legacy XCKP key-operated switch by an XCSPA switch, or a legacy XCKT key-operated switch by an XCSTA switch, without the need to drill additional fixing holes for the switch or the actuating keys.

Turret head

XCSPA, XCSTA, XCSLE and XCSTE safety interlock switches are fitted with a square turret head which can be rotated through 360° in 90° steps. XCSMP safety interlock switches have a fixed head

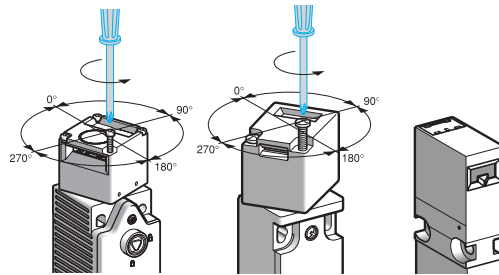

8 directions of actuation are possible for the actuating key:

- 4 in the horizontal plane (1 for XCSMP)
 - 4 from above the switch (1 for XCSMP)
- (4 alternative positions of the actuating key slot, depending on the orientation of the head)

When loosening the fixing screw(s) for re-orientation of the operating head, the head itself remains attached to the body and the contact states remain unchanged.

Safety (or main) contacts

Key-operated switches incorporate either a 2-pole contact block (XCSMP, XCSPA, XCSLE and XCSTE) or a 3-pole contact block (XCSMP, XCSPA, XCSTA, XCSLE and XCSE), with NC contacts with positive opening operation, which is actuated by insertion or withdrawal of the actuating key attached to the guard

XCSLE

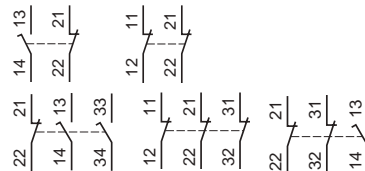

or XCSTE

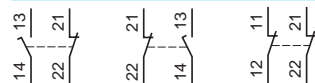

or XCSPA

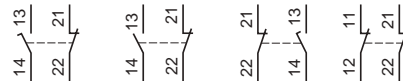

or XCSPA, XCSTA

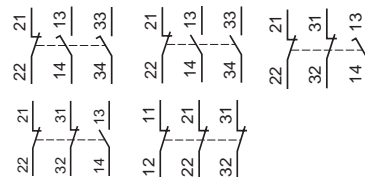

or XCSMP

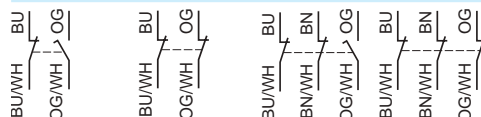

The NC contact(s) are for use in the safety circuit of the machine. Withdrawal of the actuating key opens the NC safety contact(s), even in the event of the contact sticking or welding.

The other NO contact can be used for signaling (for example: PLC, illuminated beacon, etc.).

Auxiliary contacts

Safety interlocks with solenoid (XCSLE and XCSTE) have 1 (XCSTE), 2 or 3 auxiliary contacts (XCSLE) for monitoring the solenoid position (locking monitoring) - NC contacts with positive opening operation

Guard retaining device

The XCSZ21 guard retaining device can be used with all XCSPA and XCSTA plastic case key-operated switches that are used in conjunction with either the wide (XCSZ12) or pivoting (XCSZ13) actuating key

The device maintains the guard closed by providing a retaining force of 50 N (instead of 10 N without guard retaining device).

It is especially suitable for use with light machines operating in arduous conditions (vibration, mechanical shock, guard not vertical, risk of guard rebound on closing, etc.).

It can be used for horizontal actuating key actuation directions, as well as those from above.

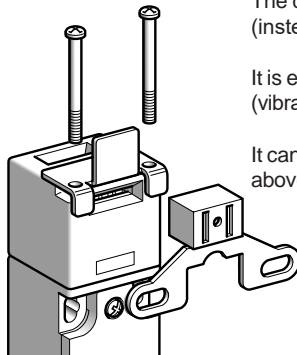

Locking/unlocking by solenoid

XCSLE and XCSTE safety interlock switches incorporate a solenoid for locking/unlocking of the machine guard

With the machine guard closed and locked, the resistance to forcible withdrawal of the actuating key fitted to the guard is $F_{zh} = 1100 \text{ N}$ (XCSLE) and $F_{zh} = 500 \text{ N}$ (XCSTE) (according to EN/ISO 14119 - $F_{zh} = F_{1max}/1.3$). In addition to the 2-pole (XCSLE, XCSTE) or 3-pole (XCSLE) contact block, positively operated by the actuating key fitted to the guard, the switches incorporate **1 NC (XCSTE), NC + NO or 2 NC (XCSLE) auxiliary contacts mechanically linked to the solenoid**. The NC contact(s) are for use in the safety circuit of the machine.

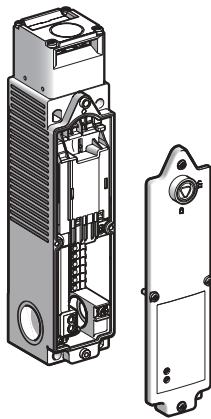

Unlocking by special tool (auxiliary release)

XCSLF and XCSE safety interlock switches are supplied with a special tool 1 that enables unlocking of the machine guard from outside the safeguarded area (for use by authorized personnel only)

Manual unlocking of the guard using the tool 1 is useful in the following cases:

- while the machine is undergoing maintenance (with the tool turned to the "UNLOCK" position and then removed, the level of protection is higher for helping to prevent an accidental machine start. The safety of maintenance personnel is thus improved)
- in the event of a power outage
- in the event of an interlocking circuit malfunction (interlocked condition maintained: positive safety). The electrical supply providing unlocking via the solenoid always takes priority over manual unlocking using the special tool.

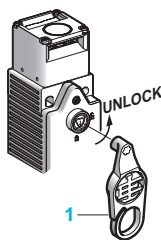

Resilience

XCSLE and XCSLF safety interlock switches provide good resistance to shocks

XCSLE Head against the fixing support: max = 1.2 J
XCSLE Head protruding from the fixing support: max = 4.9 J

XCSLF Head against the fixing support: max = 9.6 J
XCSLF Head protruding from the fixing support: max = 6.4 J

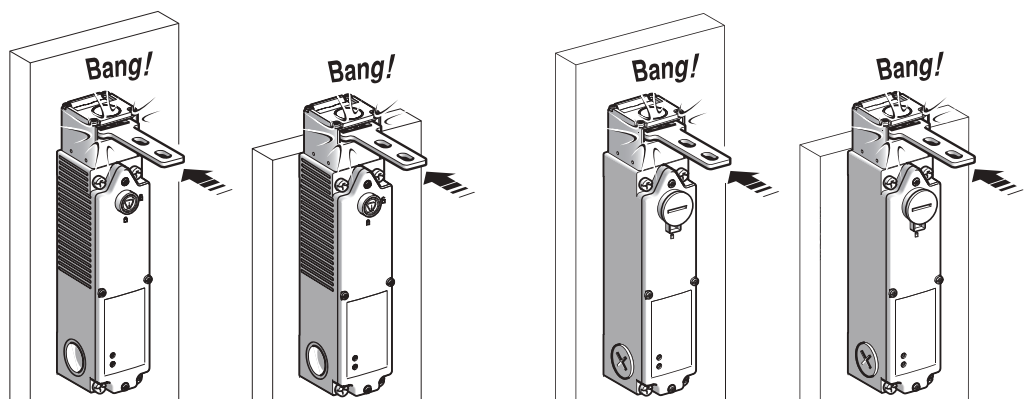

Presentation

Turret head

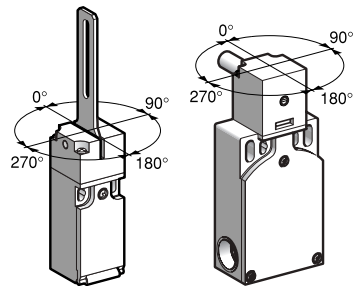

Safety switches for hinged covers or guards, featuring a hinged lever or spindle operator, incorporate a turret head that can be rotated through 360° in 90° steps. Two additional self-locking screws are included with each switch for positive fixing of the head.

2 types of body

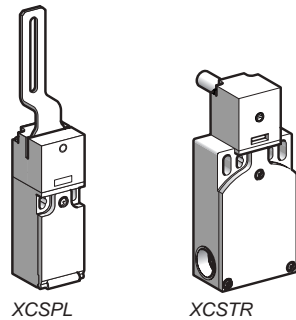

- Plastic case, narrow, with 1 cable entry for **XCSPL** and **XCSPR**.
- Plastic case, wide, with 2 cable entries for **XCSTR**.

2 types of operating lever, 2 spindle lengths

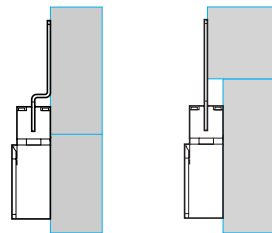

- **Levers**
Straight or elbowed (flush with rear of switch), making the lever switches suitable for use with all types of hinged guard, whether:
 - flush with the machine framework (use a switch with an elbowed flush lever)
 - overhanging in relation to the machine framework (use a switch with a straight lever)
 3 alternative operating lever positions allow the switches to be used with guards that open to the left, center or right.
- **Spindle operators**
2 spindle lengths: 30 or 80 mm.

Safety contacts

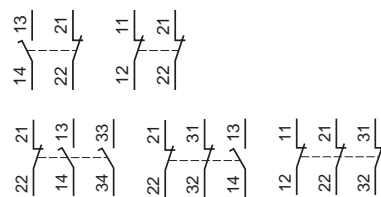

XCSPL and **XCSPR** safety switches incorporate a 2-pole or 3-pole contact block - NC contacts with positive opening operation. The contact arrangements can be: NC + NO break before make, 2 NC, 1 NC + 2 NO break before make or 2 NC + 1 NO break before make.

XCSTR safety switches incorporate a 3-pole contact block - NC contacts with positive opening operation. The contact arrangements can be: 1 NC + 2 NO break before make, 2 NC + 1 NO break before make or 3 NC. Opening of the NC safety contact(s) occurs when the operating lever or spindle is displaced by an angle equal to or greater than 5°.

Applications

These safety switches provide a solution for monitoring **hinged protective guards** with small opening radius on machines with low inertia (quick rundown time). They are especially suitable for existing machines which need to be brought in line with the latest standards and directives since they can be used in conjunction with existing covers, including those whose mounting is somewhat imprecise. Mounting of the safety switch improves the machine operator's level of safety by limiting opening of the protective guard and reducing the risk of touching any moving parts before they have come to a stop.

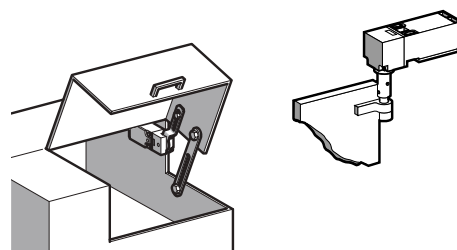

Presentation

Coded magnetic switches



XCSDMC
Compact format

XCSDMP
Standard format

XCSDMR
Cylindrical format

3 types of case

- PBT plastic body
- Compact rectangular, **XCSDMC**
- Standard rectangular, **XCSDMP**
- Cylindrical Ø 30, **XCSDMR**
- Pre-cabled, length 2 m, 5 m or 10 m
- Connector on flying lead connection:
 - M8: DMC
 - M12: DMP, DMR

Contacts

Coded magnetic switches are fitted with 2-pole (**XCSDMC/XCSDMR/XCSDMP**) or 3-pole (**XCSDMP**) Reed type contacts and are available with or without a "guard closed" LED indicator.

The NC and NO contacts change state as soon as the magnet is at a distance from the sensor of approximately 8 mm for **XCSDMP** and **XCSDMR** switches and approximately 5 mm for **XCSDMC** switches.

Coded magnetic switches have a low level of coding according to EN/ISO 14119.

Connection

When used in safety circuits, the Reed technology contacts must always be used in conjunction with a Schneider Electric safety control unit.

Contactless RFID safety switches



Standalone or
Single model

Daisy-chain model

3 model types

- Thermoplastic housing (Valox™)
- Standalone, with embedded EDM (external device monitoring) and start/restart function
- Series connection (daisy-chain)
- Point-to-point connection
- Connector:
 - M12 8-pin for standalone
 - 2 x M12 5-pin for daisy-chain model and M12 5-pin for point-to-point connection

Technology

Contactless RFID protocol.

Embedded EDM (external device monitoring) for standalone model (no need for safety control unit); diagnosis of the whole daisy chain of switches possible using the diagnostic module; point-to-point connection to a safety controller or safety PLC.

High level of coding (according to EN/ISO 14119)

- Reader and transponder are factory-paired with a unique code

Applications

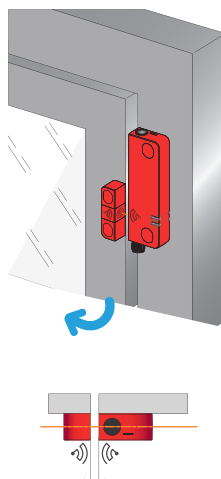

Contactless safety switches are specifically designed for industrial machines fitted with **doors, covers or guards with imprecise guiding**.

They are ideally suited for machines subjected to frequent washing or liquid spray, and for XCSR RFID safety switches, exposed to knocks and vibrations.

Presentation

XCSM safety limit switches

With head for linear movement (plunger) or rotary movement (lever)

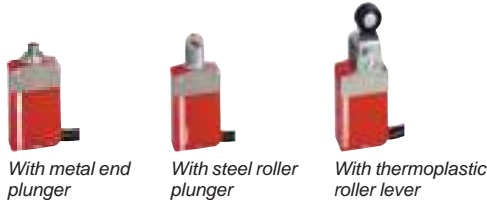

With metal end plunger

With steel roller plunger

With thermoplastic roller lever

- XCSM miniature metal case
- With protective plate, helping to prevent both access to the fixing screws and adjustment of the head by unauthorized personnel
- Torx fixing screws
- A removable cable entry to facilitate wiring

Contacts

XCSM3 limit switches are fitted with 3-pole contacts (2 NC + 1 NO snap or slow break) and XCSM4 switches are fitted with 4-pole contacts (2 NC + 2 NO snap) - NC contacts with positive opening operation.

4 versions of complete switches are available incorporating these contacts:

- metal end plunger
- roller plunger
- thermoplastic roller lever
- 19 mm diameter steel roller lever

Connection

Pre-cabled switches, either 7 x 0.5 mm² (3-pole contacts) or 9 x 0.34 mm² (4-pole contacts).

XCSD and XCSP safety limit switches

With head for linear movement (plunger) or rotary movement (lever)



With metal end plunger

With steel roller plunger

With thermoplastic roller lever

- XCSD compact metal case and XCSP plastic case
- With protective plate, helping to prevent both access to the fixing screws and adjustment of the head by unauthorized personnel
- Torx fixing screws
- A removable cable entry to facilitate wiring

Contacts

XCSP39●●● and XCSD3●●●● limit switches are fitted with 3-pole contacts.

2 NC + 1 NO snap action or slow break for XCSD3; 2 NC + 1 NO snap action for XCSP39 (NC contacts with positive opening operation)

4 versions of complete switches are available incorporating these contacts:

- metal end plunger
- roller plunger
- thermoplastic roller lever
- 19 mm diameter steel roller lever

Applications

These switches provide a solution for monitoring covers, guards or grids. For use on machines with low inertia (quick rundown time) and also on machines with high inertia (long rundown time) when used in conjunction with key-operated safety interlock switches with solenoid.

When used on their own, they are always installed in "positive mode" or combined in pairs, with one switch being in "positive mode" and the other in "negative mode", and can, when connected to Schneider Electric safety control units, achieve a PL=e, category 4/SIL 3 system.

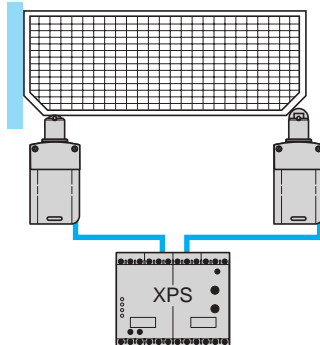

XCSM
pre-cabled

With head for linear movement (plunger). Fixing by the body



XCSM with plunger

Page 28

With head for rotary movement (lever). Fixing by the body



XCSM with lever

Page 28

Environmental characteristics

Conformity to standards	Products	EN/IEC 60947-5-1, UL 508, CSA C22-2 no. 14
	Machine assemblies	EN/IEC 60204-1, EN/ISO 14119
Product certifications		UL, CSA, CCC, EAC
Maximum safety level (1)		PL=e, category 4 conforming to EN/ISO 13849-1 and SIL CL3 conforming to EN/IEC 62061
Reliability data B_{10D}		50,000,000 (value given for a service life of 20 years, limited by mechanical or contact wear)
Ambient air temperature		For operation: -25...+70 °C For storage: -40...+70 °C
Vibration resistance		XCSM snap action: 5 gn. XCSM slow break: 25 gn (10...500 Hz) conforming to EN/IEC 60068-2-6
Shock resistance		25 gn (18 ms) conforming to EN/IEC 60068-2-27
Electric shock protection		Class I conforming to EN/IEC 61140
Degree of protection		IP 66, IP 67 and IP 68 (2) conforming to EN/IEC 60529; IK 06 conforming to IEC 62262
Materials		Body: Zamak. Head: Zamak. Protective plate: steel, fixed with 5-lobe torque safety screws. Cable: PVC.
Repeat accuracy		0.05 mm on the tripping points, with 1 million operating cycles for head with end plunger

Contact block characteristics

Rated operational characteristics	~ AC-15; C300 (U _e = 240 V, I _e = 0.75 A) --- DC-13; R300 (U _e = 250 V, I _e = 0.1 A), conforming to EN/IEC 60947-5-1 Appendix A
Conventional thermal current in enclosure	3 snap action contact and 3 slow break contact versions: I _{the} = 4 A 4 snap action contact version: I _{the} = 3 A
Rated insulation voltage	U _i = 400 V degree of pollution 3 conforming to EN/IEC 60947-5-1 U _i = 300 V conforming to UL 508, CSA C22-2 no. 14
Rated impulse withstand voltage	U _{imp} = 4 kV conforming to EN/IEC 60947-1, EN/IEC 60664
Positive operation (depending on model)	NC contacts with positive opening operation conforming to IEN/IEC 60947-5-1 Appendix K
Resistance across terminals	≤ 25 mΩ conforming to EN/IEC 60255-7 category 3
Short-circuit protection	6 A cartridge fuse type gG (gl)
Minimum actuation speed	Snap action contact: 0.01 m/minute, Break before make, slow break contact: 6 m/minute

(1) Using an appropriate and correctly connected safety control unit.

(2) Protection against prolonged immersion: the test conditions are subject to agreement between the manufacturer and the user.

Electrical durability

- Conforming to EN/IEC 60947-5-1 Appendix C
- Utilization categories AC-15 and DC-13
- Maximum operating rate: 3,600 operating cycles/hour
- Load factor: 0.5

AC supply
50/60 Hz ~
mm inductive circuit

**XCSM snap action
(2 NC + 1 NO, 2 NC + 2 NO contact)**

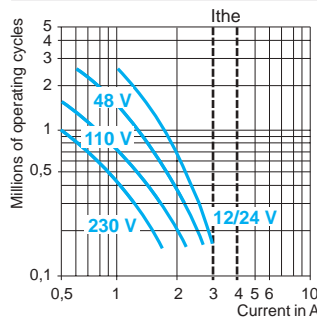

**XCSM slow break
(2 NC + 1 NO contact)**

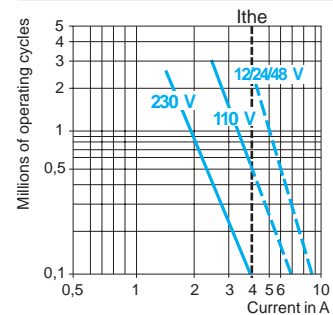

DC supply ---
**Power broken in W for
5 million operating cycles**

Voltage	V	24	48	120
mm	W	3	2	1

Power broken in W for
5 million operating cycles

Voltage	V	24	48	120
mm	W	4	3	3

(1) Protection against prolonged immersion: the test conditions are subject to agreement between the manufacturer and the user.



Safety detection solutions

Safety limit switches
XCSM miniature design, metal
Pre-cabled

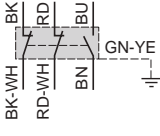
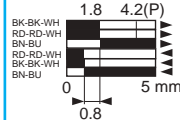
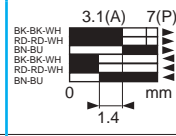
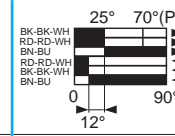
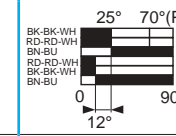
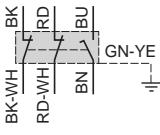

Type of head	Plunger (fixing by the body)		Rotary (fixing by the body)	
				

Type of operator	Metal end plunger	Roller plunger	Thermoplastic roller lever	Steel roller lever
------------------	-------------------	----------------	----------------------------	--------------------

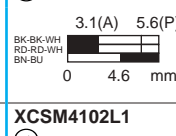
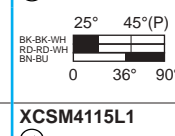
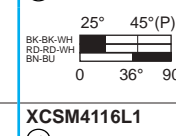
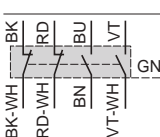
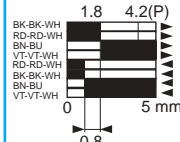
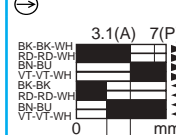
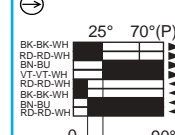
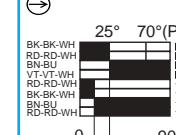
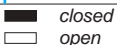
References (⊖ NC contact with positive opening operation)

 <p>3-pole 2 NC + 1 NO snap action contact</p>	<p>XCSM3910L1</p> 	<p>XCSM3902L1</p> 	<p>XCSM3915L1</p> 	<p>XCSM3916L1</p> 
 <p>3-pole 2 NC + 1 NO break before make, slow break contact</p>	<p>XCSM3710L1</p> 	<p>XCSM3702L1</p> 	<p>XCSM3715L1</p> 	<p>XCSM3716L1</p> 
 <p>4-pole 2 NC + 2 NO snap action contact</p>	<p>XCSM4110L1</p> 	<p>XCSM4102L1</p> 	<p>XCSM4115L1</p> 	<p>XCSM4116L1</p> 
Weight (kg)	0.165	0.170	0.205	0.210
Contact operation			(A) = cam displacement (P) = positive opening point ⊖ NC contact with positive opening operation	

Complementary characteristics not shown under general characteristics (page 27)

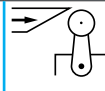
Switch actuation	On end	By 30° cam	
Type of actuation			
Maximum actuation speed	0.5 m/s	0.5 m/s	1.5 m/s
Mechanical durability	10 million operating cycles		
Minimum force or torque	Tripping	8.5 N	7 N
	Positive opening	42.5 N	35 N
Cabling	3-pole contacts	PVC pre-cabled, 7 x 0.5 mm ² , length 1 m (1)	
	4-pole contacts	PVC pre-cabled, 9 x 0.34 mm ² , length 1 m (1)	

(1) For a 2 m long cable, replace L1 with L2.
For a 5 m long cable, replace L1 with L5.

Dimensions

XCSM●●10L1

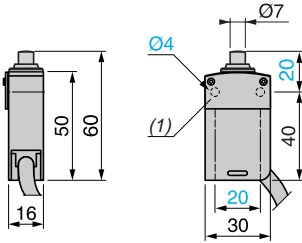

(1) Protective plate fixed by 5-lobe torque safety screws.

XCSM●●02L1

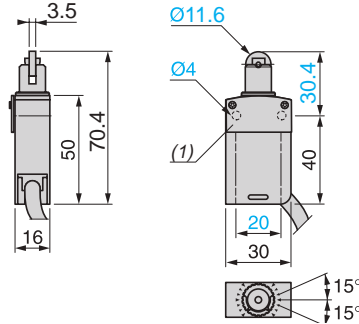

XCSM●●15L1

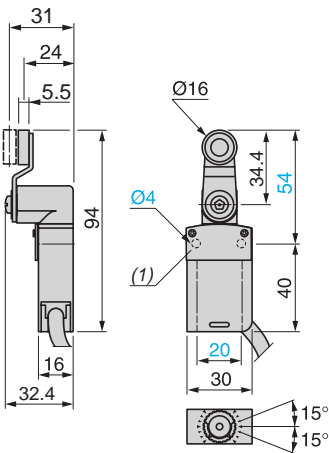

(1) Protective plate fixed by 5-lobe torque safety screws.

XCSM●●16L1

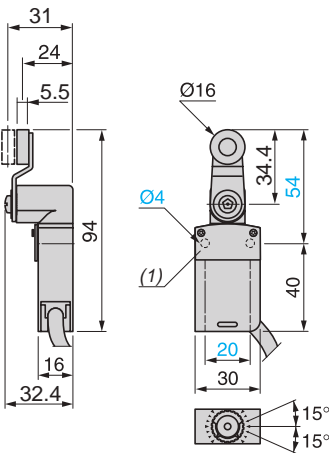

Connections

Wiring up to PL = b, category 1 conforming to EN/ISO 13849-1

Example with 3-pole 2 NC + 1 NO contact and protection fuse to help prevent shunting of the N/C contacts, due to either cable damage or tampering.

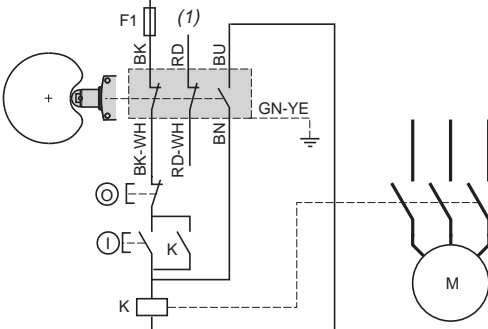

(1) Signaling contact

Wiring up to PL = d, category 3 conforming to EN/ISO 13849-1

Example with 3-pole 2 NC + 1 NO contact with mixed redundancy of the contacts and the associated control relays. Opening and closing of the guard necessary to activate K1.

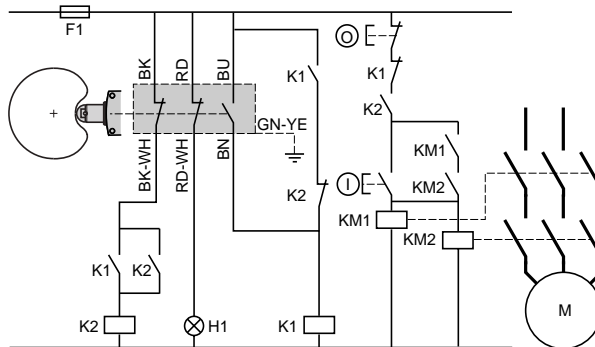

H1: "Guard closed" indicator light

Example of guard monitoring using 2 switches and 1 safety control unit (PL=e, category 4 conforming to EN/ISO 13849-1)

Operation in positive and negative (combined) mode

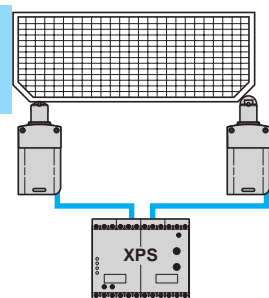

Safety detection solutions

Safety limit switches

Compact design

XCSD, metal

XCSP, plastic

XCSD, XCSP

with 1 cable entry

Conforming to standard EN 50047

With head for linear movement (plunger)

XCSD

XCSP

107870



Metal end plunger

Page 32



Roller plunger

PF130726



Metal end plunger

Page 34

PF130727



Roller plunger

With head for rotary movement (lever)

XCSD

XCSP

107872



Thermoplastic roller lever

Page 32

107873



Steel roller lever

PF130728



Thermoplastic roller lever

Page 34

PF130729



Steel roller lever

Environmental characteristics

Conformity to standards	Products	EN/IEC 60947-5-1, UL 508, CSA C22-2 no. 14
	Machine assemblies	EN/IEC 60204-1, EN/ISO 14119
Product certifications		UL, CSA, CCC, EAC
Maximum safety level (1)		PL=e, category 4 conforming to EN/ISO 13849-1 and SIL CL3 conforming to EN/IEC 62061
Reliability data B_{10D}		50,000,000 (value given for a service life of 20 years, limited by mechanical or contact wear)
Ambient air temperature	For operation	-25...+70 °C
	For storage	-40...+70 °C
Vibration resistance	Conforming to EN/IEC 60068-2-6	25 gn (10...500 Hz)
Shock resistance	Conforming to EN/IEC 60068-2-27	50 gn (11 ms)
Electric shock protection		Class I conforming to EN/IEC 61140 for XCSD Class II conforming to EN/IEC 61140 for XCSP
Degree of protection	Conforming to EN/IEC 60529	IP 66 and IP 67
	Conforming to IEC 62262	IK 06 for XCSD IK 04 for XCSP
Repeat accuracy		0.1 mm on the tripping points, with 1 million operating cycles for head with end plunger
Cable entry	Depending on model	Tapped entry for Pg 13.5 cable gland, tapped ISO M20 x 1.5 or tapped 1/2" NPT
Materials		XCSD: Zamak bodies and heads, XCSP: plastic bodies, Zamak heads Plastic protective cover, fixed with 5-lobe torque safety screws

Contact block characteristics

Rated operational characteristics		~ AC-15; B300 (U _e = 240 V, I _e = 1.5 A) ⋮ DC-13; R300 (U _e = 250 V, I _e = 0.1 A), conforming to EN/IEC 60947-5-1 Appendix A
Conventional thermal current in enclosure		3 snap action contact and 3 slow break contact versions: I _{the} = 6 A
Rated insulation voltage		U _i = 400 V degree of pollution 3 conforming to IEN/IEC 60947-1 U _i = 300 V conforming to UL 508, CSA C22-2 no. 14
Rated impulse withstand voltage		U _{imp} = 4 kV conforming to EN/IEC 60947-1, EN/IEC 60664
Positive operation (depending on model)		NC contacts with positive opening operation conforming to IEN/IEC 60947-5-1 Appendix K
Resistance across terminals		≤ 25 mΩ conforming to EN/IEC 60255-7 category 3
Short-circuit protection		6 A cartridge fuse type gG (gl)
Connection (screw clamp terminals)		Clamping capacity, min: 1 x 0.34 mm ² , max: 1 x 1 mm ² or 2 x 0.75 mm ²
Minimum actuation speed (for head with end plunger)	Snap action	0.01 m/minute
	Slow break	6 m/minute

(1) Using an appropriate and correctly connected safety control unit.

Electrical durability

- Conforming to EN/IEC 60947-5-1 Appendix C
- Utilization categories AC-15 and DC-13
- Maximum operating rate: 3,600 operating cycles/hour
- Load factor: 0.5

AC supply
50/60 Hz ~
mm inductive circuit

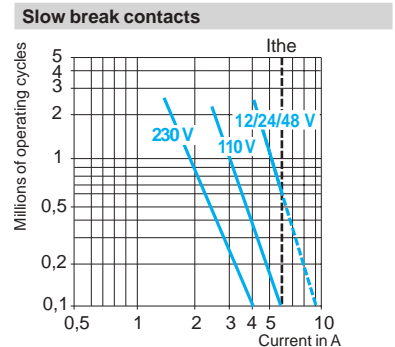
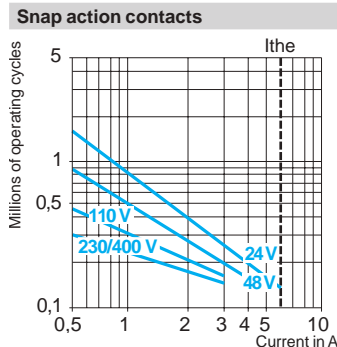

DC supply ⋮
Power broken in W for 5 million operating cycles.

Voltage V	24	48	120
mm W	3	2	1

Voltage V	24	48	120
mm W	4	3	2

Safety detection solutions

Safety limit switches

XCSD compact design, metal

Complete switches, 1 cable entry

Type of head	Plunger		Rotary	
				

Type of operator	Metal end plunger	Steel roller plunger	Thermoplastic roller lever	Steel roller lever
------------------	-------------------	----------------------	----------------------------	--------------------

References of complete switches with 3-pole 2 NC + 1 NO snap action contact

(⊖ NC contact with positive opening operation)

With ISO M20 x 1.5 cable entry	XCSD3910P20	XCSD3902P20	XCSD3918P20	XCSD3919P20
	⊖	⊖	⊖	⊖
With Pg 13.5 cable entry	XCSD3910G13	XCSD3902G13	XCSD3918G13	XCSD3919G13
	⊖	⊖	⊖	⊖
With 1/2" NPT cable entry	XCSD3910N12	XCSD3902N12	XCSD3918N12	XCSD3919N12
	⊖	⊖	⊖	⊖
Weight (kg)	0.215	0.220	0.255	0.255

Contact function diagrams

	1.8 4.5(P)	3.1(A) 7.8(P)	25° 70°(P)	25° 70°(P)
3-pole 2 NC + 1 NO snap action				
Contact operation	<p>□ closed (A) = cam displacement</p> <p>□ open (P) = positive opening point</p> <p>⊖ NC contact with positive opening operation</p>			

Characteristics

Switch actuation	On end	By 30° cam	
Type of actuation			
Maximum actuation speed	0.5 m/s		1.5 m/s
Mechanical durability (in millions of operating cycles)	15	10	
Minimum force or torque	For tripping: 15 N For positive opening: 45 N	12 N 36 N	0.1 N.m/0.88 lb-in 0.25 N.m/2.21 lb-in
Cable entry	1 entry tapped M20 x 1.5 mm for ISO cable gland, clamping capacity 7 to 13 mm 1 entry tapped for Pg13.5 cable gland, clamping capacity 9 to 12 mm 1 entry tapped for 1/2" NPT conduit		

Dimensions

XCSD3●10●●●

XCSD3●02●●●

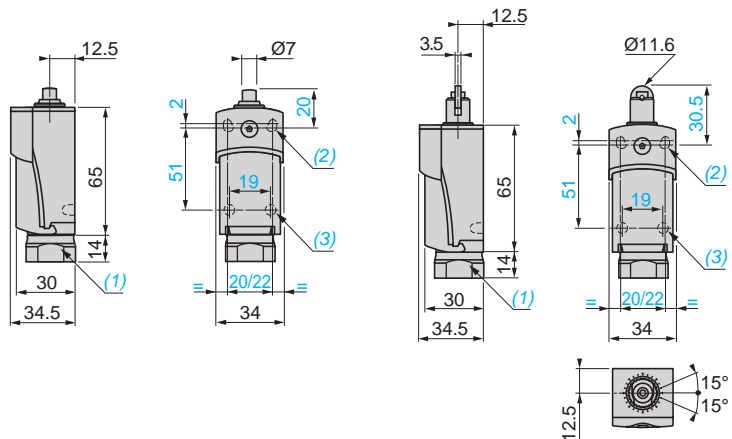

- (1) Tapped entry for ISO M20 x 1.5 or Pg 13.5 cable gland or tapped 1/2" NPT.
- (2) 2 elongated holes $\varnothing 4.3 \times 6.3$ mm on 22 mm centers, 2 holes $\varnothing 4.3$ on 20 mm centers.
- (3) 2 x $\varnothing 3$ holes for support studs, depth 4 mm.

Safety detection solutions

Safety limit switches
XCSD compact design, metal
Complete switches, 1 cable entry

Type of head	Plunger		Rotary	
				

Type of operator	Metal end plunger	Steel roller plunger	Thermoplastic roller lever	Steel roller lever
------------------	-------------------	----------------------	----------------------------	--------------------

References of complete switches with 3-pole 2 NC + 1 NO break before make, slow break contact
(⊖ NC contact with positive opening operation)

With ISO M20 x 1.5 cable entry	XCS3710P20	XCS3702P20	XCS3718P20	XCS3719P20
	⊖	⊖	⊖	⊖
With Pg 13.5 cable entry	XCS3710G13	XCS3702G13	XCS3718G13	XCS3719G13
	⊖	⊖	⊖	⊖
With 1/2" NPT cable entry	XCS3710N12	XCS3702N12	XCS3718N12	XCS3719N12
	⊖	⊖	⊖	⊖
Weight (kg)	0.215	0.220	0.255	0.255

Contact function diagrams

3-pole 2 NC + 1 NO break before make, slow break	1.8 3.2(P)	3.1(A) 5.6(P)	25° 70°(P)	25° 70°(P)
	0 3 5mm	0 5.2 mm	0 42° 90°	0 42° 90°
Legend:	■ closed (A) = cam displacement □ open (P) = positive opening point ⊖ NC contact with positive opening operation			

Characteristics

Switch actuation	On end	By 30° cam	
Type of actuation			
Maximum actuation speed	0.5 m/s		1.5 m/s
Mechanical durability (In millions of operating cycles)	15	10	
Minimum force or torque	For tripping: 15 N For positive opening: 45 N	12 N 36 N	0.1 N.m/0.88 lb-in 0.25 N.m/2.21 lb-in
Cable entry	1 entry tapped M20 x 1.5 mm for ISO cable gland, clamping capacity 7 to 13 mm 1 entry tapped for Pg13.5 cable gland, clamping capacity 9 to 12 mm 1 entry tapped for 1/2" NPT conduit		

Dimensions

XCS3●18●●●, XCS3●19●●●

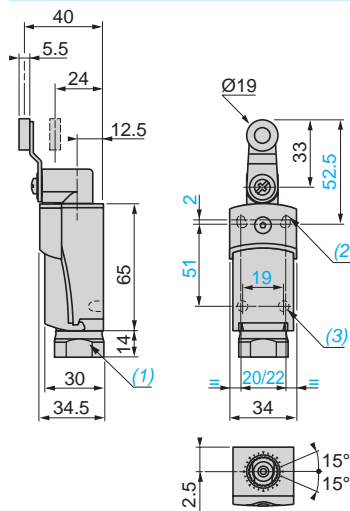

- (1) Tapped entry for ISO M20 x 1.5 or Pg 13.5 cable gland or tapped 1/2" NPT.
- (2) 2 elongated holes Ø 4.3 x 6.3 mm on 22 mm centers, 2 holes Ø 4.3 on 20 mm centers.
- (3) 2 x Ø 3 holes for support studs, depth 4 mm.

Safety detection solutions

Safety limit switches

XCSP compact design, plastic

Complete switches, 1 cable entry

Type of head	Plunger		Rotary	
				

Type of operator	Metal end plunger	Steel roller plunger	Thermoplastic roller lever	Steel roller lever
------------------	-------------------	----------------------	----------------------------	--------------------

References of complete switches with 3-pole 2 NC + 1 NO snap action contact

(⊖ NC contact with positive opening operation)

With ISO M20 x 1.5 cable entry

	XCSP3910P20 ⊖	XCSP3902P20 ⊖	XCSP3918P20 ⊖	XCSP3919P20 ⊖
--	------------------	------------------	------------------	------------------

With Pg 13.5 cable entry

	XCSP3910G13 ⊖	XCSP3902G13 ⊖	XCSP3918G13 ⊖	XCSP3919G13 ⊖
--	------------------	------------------	------------------	------------------

With 1/2" NPT cable entry

	XCSP3910N12 ⊖	XCSP3902N12 ⊖	XCSP3918N12 ⊖	XCSP3919N12 ⊖
--	------------------	------------------	------------------	------------------

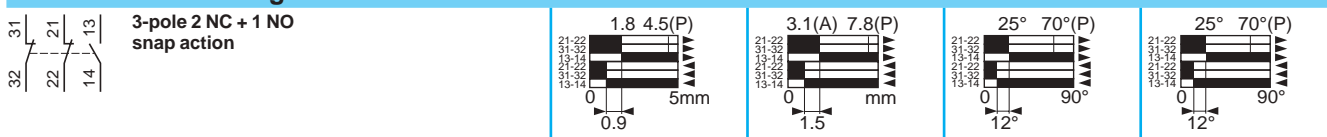

Weight (kg)	0.215	0.220	0.255	0.255
-------------	-------	-------	-------	-------

Contact function diagrams



Contact operation	<p>■ closed (A) = cam displacement</p> <p>□ open (P) = positive opening point</p> <p>⊖ NC contact with positive opening operation</p>
-------------------	---

Characteristics

Switch actuation	On end	By 30° cam	
Type of actuation			
Maximum actuation speed	0.5 m/s		1.5 m/s
Mechanical durability (in millions of operating cycles)	15	10	
Minimum force or torque	For tripping	15 N	0.1 N.m/0.88 lb-in
	For positive opening	45 N	0.25 N.m/2.21 lb-in
Cable entry	1 entry tapped M20 x 1.5 mm for ISO cable gland, clamping capacity 7 to 13 mm 1 entry tapped for Pg 13.5 cable gland, clamping capacity 9 to 12 mm 1 entry tapped for 1/2" NPT conduit		

Dimensions

XCSP3910●●●

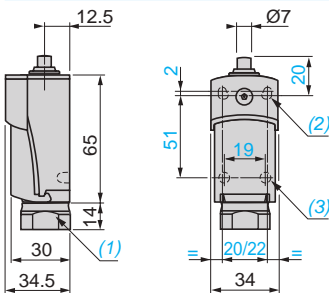

XCSP3902●●●

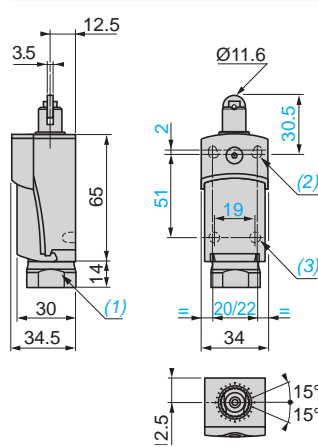

XCSP3918●●●, XCSP3919●●●

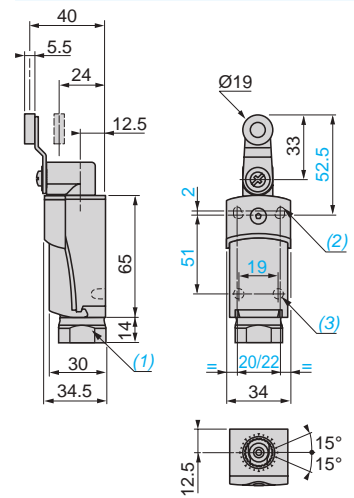

- (1) Tapped entry for ISO M20 x 1.5 or Pg 13.5 cable gland or tapped 1/2" NPT.
 (2) 2 elongated holes $\varnothing 4.3 \times 6.3$ mm on 22 mm centers, 2 holes $\varnothing 4.3$ on 20 mm centers.
 (3) 2 x $\varnothing 3$ holes for support studs, depth 4 mm.

Safety detection solutions

Lever or spindle-operated safety switches
XCSP, XCSR and XCSTR
plastic, double insulated, turret head

XCSP with 1 cable entry

With rotary operating head, with elbowed lever (flush with rear of switch) or straight lever, for hinged covers and guards



Page 38

XCSR with 1 cable entry

With rotary operating head, with spindle operator, for hinged covers and guards



Page 38

XCSTR with 2 cable entries

With rotary operating head, with spindle operator, for hinged covers and guards



Page 38

Environmental characteristics

Conformity to standards	Products	EN/IEC 60947-5-1, EN/IEC 60947-5-4, UL 508, CSA C22-2 no. 14
	Machine assemblies	EN/IEC 60204-1, EN/ISO 14119
Product certifications		UL, CSA, CCC, EAC
Maximum safety level (1)		PL=e, category 4 conforming to EN/ISO 13849-1 and SIL CL3 conforming to EN/IEC 62061
Reliability data B_{10D}		5,000,000 (value given for a service life of 20 years, limited by mechanical or contact wear)
Ambient air temperature	For operation	-25...+70 °C
	For storage	-40...+70 °C
Vibration resistance		50 gn (10...500 Hz) conforming to EN/IEC 60068-2-6
Shock resistance		50 gn (duration 11 ms) conforming to EN/IEC 60068-2-27
Electric shock protection		Class II conforming to EN/IEC 61140
Degree of protection		IP 67 conforming to EN/IEC 60529
Cable entry		<p>XCSP and XCSR: 1 entry tapped M16 x 1.5 for:</p> <ul style="list-style-type: none"> ■ ISO cable gland (clamping capacity 4.5 to 10 mm) or ■ Pg 11 cable gland (clamping capacity 7 to 10 mm) or ■ 1/2" NPT conduit. <p>XSTR: 2 entries tapped M16 x 1.5 for:</p> <ul style="list-style-type: none"> ■ ISO cable gland (clamping capacity 4.5 to 10 mm) or ■ Pg 11 cable gland (clamping capacity 7 to 10 mm) or ■ 1/2" NPT conduit using the DE9 RA1012 adapter in one of the Pg 11 tapped entries and a blanking plug in the other.
Materials		Polyamide PA66 fibreglass impregnated case. Stainless steel lever and fixings

(1) Using an appropriate and correctly connected safety control unit.

Safety detection solutions

Lever or spindle-operated safety switches
XCSP, XCSPR and XCSTR
plastic, double insulated, turret head

Contact block characteristics		
Rated operational characteristics	2 and 3-contact versions	XCSP (2-contact version), XCST (3 contacts): ~ AC-15, A300: $U_e = 240\text{ V}$, $I_e = 3\text{ A}$ or $U_e = 120\text{ V}$, $I_e = 6\text{ A}$ --- DC-13, Q300: $U_e = 250\text{ V}$, $I_e = 0.27\text{ A}$ or $U_e = 125\text{ V}$, $I_e = 0.55\text{ A}$ conforming to EN/IEC 60947-5-1
	3-contact version	XCSP (3-contact version): ~ AC-15, B300: $U_e = 240\text{ V}$, $I_e = 1.5\text{ A}$ or $U_e = 120\text{ V}$, $I_e = 3\text{ A}$ --- DC-13, R300: $U_e = 250\text{ V}$, $I_e = 0.1\text{ A}$ or $U_e = 125\text{ V}$, $I_e = 0.2\text{ A}$ conforming to EN/IEC 60947-5-1
Conventional thermal current in enclosure	2 and 3-contact versions	XCSP (2-contact version), XCST (3 contacts): $I_{the} = 10\text{ A}$
	3-contact version	XCSP (3-contact version): $I_{the} = 6\text{ A}$
Rated insulation voltage	2 and 3-contact versions	XCSP (2-contact version), XCST (3 contacts): $U_i = 500\text{ V}$ degree of pollution 3 conforming to EN/IEC 60947-1 $U_i = 300\text{ V}$ conforming to UL 508, CSA C22-2 no. 14
	3-contact version	XCSP (3-contact version): $U_i = 400\text{ V}$ degree of pollution 3 conforming to EN/IEC 60947-1 $U_i = 300\text{ V}$ conforming to UL 508, CSA C22-2 no. 14
Rated impulse withstand voltage	2 and 3-contact versions	XCSP (2-contact version), XCST (3 contacts): $U_{imp} = 6\text{ kV}$ conforming to EN/IEC 60947-5-1
	3-contact version	XCSP (3-contact version): $U_{imp} = 4\text{ kV}$ conforming to EN/IEC 60947-5-4
Positive operation	NC contacts with positive opening operation conforming to EN/IEC 60947-5-1 Appendix K	
Resistance across terminals	$\leq 30\text{ m}\Omega$ conforming to EN/IEC 60947-5-4	
Short-circuit protection	2 and 3-contact versions	XCSP (2-contact version), XCST (3 contacts): 10 A cartridge fuse type gG (gl)
	3-contact version	XCSP (3-contact version): 6 A cartridge fuse type gG (gl)
Connection	2 and 3-contact versions	XCSP (2-contact version), XCST (3 contacts): Clamping capacity, min: $1 \times 0.5\text{ mm}^2$, max: $2 \times 1.5\text{ mm}^2$ with or without cable end
	3-contact version	XCSP (3-contact version): Clamping capacity, min: $1 \times 0.34\text{ mm}^2$, max: $1 \times 1\text{ mm}^2$ or $2 \times 0.75\text{ mm}^2$
Minimum actuation speed	2 and 3-contact versions	0.1 m/second

Complementary characteristics		
Tripping angle	5°	
Mechanical durability	1 million operating cycles	
Minimum torque	For tripping	0.1 N.m/0.88 lb-in
	For positive opening	0.25 N.m/2.21 lb-in (XCSP and XCSPR) 0.45 N.m/3.98 lb-in (XCSTR)

Electrical durability

- Conforming to EN/IEC 60947-5-1 Appendix C
- Utilization categories AC-15 and DC-13
- Load factor: 0.5
- Maximum operating rate: 3600 operating cycles/hour

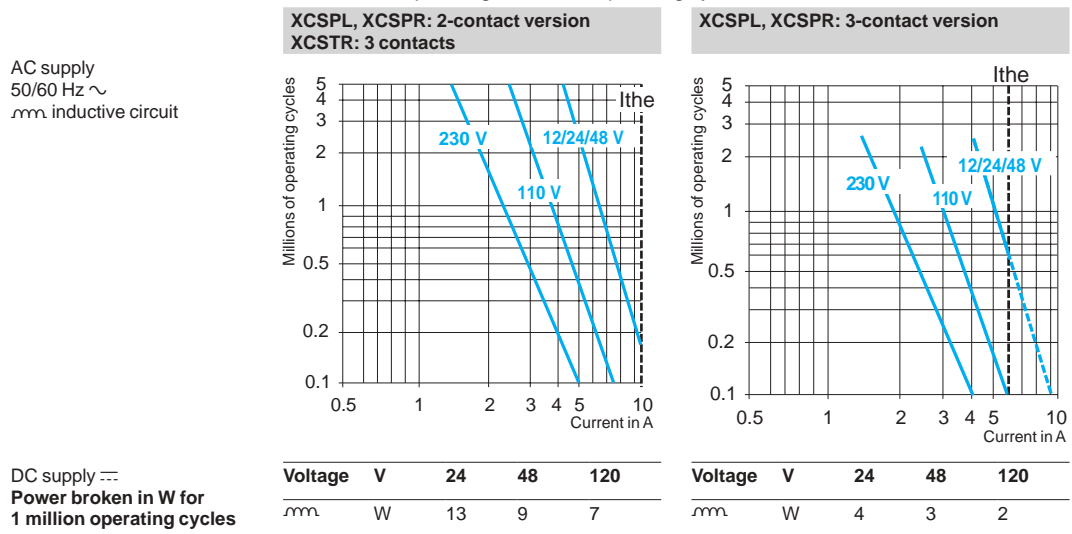

Safety detection solutions

Lever or spindle-operated safety switches

XCSP, XCSPL and XCSTR

plastic, double insulated, turret head (1)
1 or 2 cable entries

Type of switch	Elbowed lever (flush with rear of switch)			Straight lever		Spindle	
Operator	To left	Centered	To right	To right OR to left	Centered	Length 30 mm (2)	
References of complete switches (⊖ NC contact with positive opening operation) with 1 cable entry tapped ISO M16 x 1.5							
2-pole 1 NC + 1 NO break before make, slow break		XCSP592	XCSP582	XCSP572	XCSP562	XCSP552	–
2-pole 2 NC slow break		XCSP792	XCSP782	XCSP772	XCSP762	XCSP752	XCSPR752
3-pole 1 NC + 2 NO break before make, slow break		–	–	–	XCSP862	–	XCSTR552
3-pole 2 NC + 1 NO break before make, slow break		–	–	–	XCSP962	–	XCSPR952
3-pole 3 NC slow break		–	–	–	–	–	XCSTR852
Weight (kg)		0.095	0.095	0.095	0.095	0.105	0.155

References of complete switches with 1 or 2 cable entries tapped no. 11 (Pg 11)

To order a complete switch with 1 or 2 Pg 11 cable entries, replace the last number in the reference (2) with 1.
Example: XCSP752 becomes **XCSP751** (some Pg 11 references may not be available).

References of complete switches with 1 or 2 cable entries for 1/2" NPT conduit

To order a complete **XCSP●●●** or **XCSPR●●●** switch with 1 cable entry for 1/2" NPT conduit, replace the last number in the reference (2) with 3.
Example: XCSP592 becomes **XCSP593** (some 1/2" NPT references may not be available).
For a complete **XCSTR** switch with 2 entries for 1/2" NPT conduit, use DE9RA1012 adapter.



DE9RA1012

Description	Sold in lots of 10	Unit reference	Weight kg
1/2" NPT conduit adapter	10	DE9RA1012	0.050

(1) Head adjustable in 90° steps through 360°. Switches supplied with 2 additional self-locking screws for positive fixing of the head.

(2) For switches with 80 mm spindle: replace the second number in the reference (5) with 6. Example: XCSPR552 becomes **XCSPR562**. The weight increases by 0.032 kg (some 80 mm spindle references may not be available).

Other versions: please consult our Customer Care Center.

Setting-up

Operator displacement

XCSPLe9e, PLe7e, PLe6e

XCSPLe8e, PLe5e

XCSPR5e

XCSTR5e



Functional diagrams

XCSPLe59e, PL57e, PL56e

XCSPLe58e, PL55e

XCSPR55e

XCSPR95e

XCSTR55e

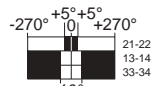
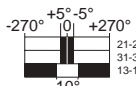
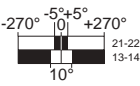
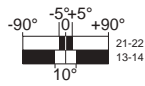
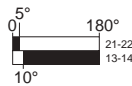

XCSPLe79e, PL77e, PL76e

XCSPLe78e, PL75e

XCSPR75e

XCSTR75e

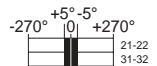
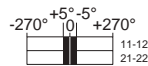
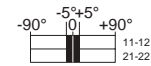
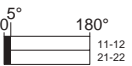

Contact operation

■ closed
□ open

XCSPLe98e

XCSPR85e

XCSTR85e

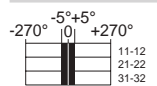
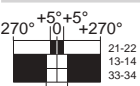
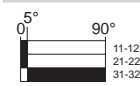

Dimensions

XCSPLe...

XCSPR...

XCSTR...

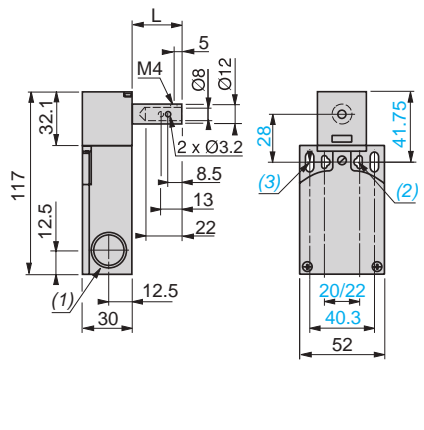
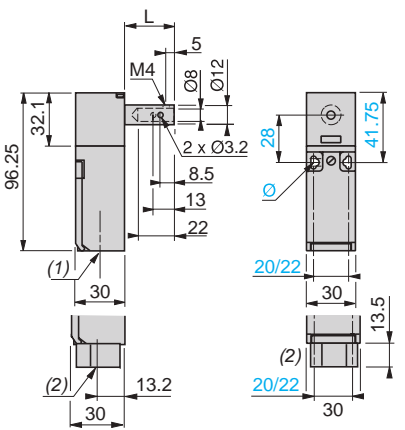
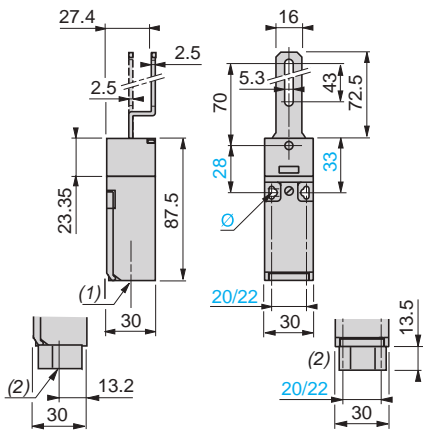

- (1) 1 entry tapped ISO M16 x 1.5 or tapped for Pg 11 cable gland
- (2) 1 entry tapped for 1/2" NPT conduit
- Ø: 2 elongated holes Ø 4.3 x 8.3 on 22 centers, 2 holes Ø 4.3 on 20 centers

- (1) 1 entry tapped for Pg 11 cable gland
- (2) 1 entry tapped for 1/2" NPT conduit
- Ø: 2 elongated holes Ø 4.3 x 8.3 on 22 centers, 2 holes Ø 4.3 on 20 centers
- L = 30 (XCSPR5e) or 80 (XCSPR6e)

- (1) 2 entries tapped ISO M16 x 1.5 or tapped for Pg 11 cable gland
- (2) 2 elongated holes Ø 4.3 x 8.3 on 22 centers, 2 holes Ø 4.3 on 20 centers
- (3) 2 elongated holes Ø 5.3 x 13.3
- L = 30 (XCSTR5e) or 80 (XCSTR6e)

Schemes

Wiring up to PL=b, category 1 conforming to EN/ISO 13849-1

Example with cable short-circuit protection fuse

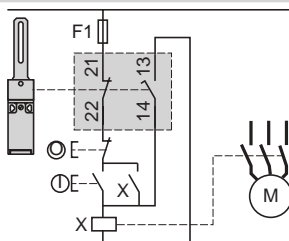

Wiring up to PL=d, category 3 conforming to EN/ISO 13849-1

Example with 3-pole 1 NC + 2 NO contact with mixed redundancy of the contacts and the associated control relays

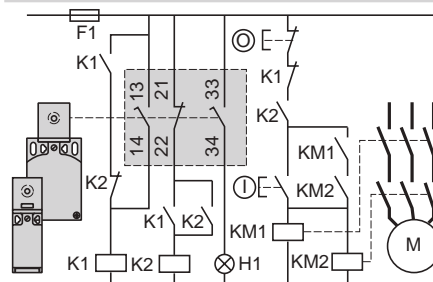

To activate K1, the lever or spindle needs to be rotated when the supply is switched on.

H1: "lever or spindle displaced from initial position" indicator. When used in conjunction with an appropriate safety control unit and another safety switch, the rotary lever or spindle-operated switch can provide locking protection to PL=d, category 3 or PL=e, category 4 conforming to EN/ISO 13849-1.

Safety detection solutions

Key-operated safety switches

XCSA, XCSB and XCSC metal, turret head

XCSMP, XCSPA and XCSTA

plastic, double insulated, turret head

XCSA, XCSB, XCSC metal

Key-operated switches with or without locking of the actuating key



XCSA



XCSB



XCSC

Page 50

XCSMP, XCSPA, XCSTA plastic

Key-operated switches without locking of the actuating key



XCSMP



XCSPA



XCSTA

Page 42

Environmental characteristics

Key-operated switch type		XCSA, XCSB, XCSC (metal)	XCSMP, XCSPA, XCSTA (plastic)
Conformity to standards	Products	EN/IEC 60947-5-1, UL 508, CSA C22-2 no. 14	
	Machine assemblies	EN/IEC 60204-1, EN/ISO 14119	
Product certifications		UL, CSA, CCC, EAC	UL, CSA, CCC, EAC (cULus, EAC for XCSMP)
Maximum safety level (1)		PL=e, category 4 conforming to EN/ISO 13849-1 and SIL CL3 conforming to EN/IEC 62061	
Reliability data B _{10D}		XCSA/PA/TA/MP: 5,000,000 XCSB/C: 3,000,000 (value given for a service life of 20 years, limited by mechanical or contact wear)	
Ambient air temperature	For operation	-25...+70 °C	
	For storage	-40...+70 °C (-25...+80 °C for XCSMP)	
Vibration resistance		5 gn (10...500 Hz) conforming to EN/IEC 60068-2-6 (6 gn (10...55 Hz) for XCSMP)	
Shock resistance		10 gn (duration 11 ms) conforming to EN/IEC 60068-2-27 (50 gn (duration 11 ms) for XCSMP)	
Electric shock protection		Class I conforming to EN/IEC 61140	Class II conforming to EN/IEC 61140
Degree of protection		IP 67 conforming to EN/IEC 60529 and EN/IEC 60947-5-1 (2)	
Cable entry		1 entry tapped ISO M20 x 1.5 (clamping capacity 7 to 13 mm) or tapped for Pg 13.5 cable gland (clamping capacity 9 to 12 mm) or for 1/2" NPT conduit	1 entry (XCSPA) or 2 entries (XCSTA) tapped for ISO M16 x 1.5 cable gland (clamping capacity 4.5 to 10 mm) or for Pg 11 cable gland, or tapped 1/2" NPT, or for 1/2" NPT conduit using metal adapter DE9RA1012) for XCSTA (other entry fitted with blanking plug).
Connecting cable		–	Pre-cabled, either 4 x 0.5 mm ² or 6 x 0.5 mm ² (XCSMP)
Materials		Zamak case	Polyamide PA66 fibreglass impregnated case
		Actuating keys (all types): steel XC60, surface treated	

(1) Using an appropriate and correctly connected safety control unit

(2) Live parts of these switches are protected to some extent against the penetration of dust and water. However, when installing take all necessary precautions to help prevent the penetration of solid bodies, or liquids with a high dust content, into the actuating key aperture. Use of blanking plugs in unused key slots can reduce the penetration of unwanted elements (XCSZ28 for XCSMP and XCSZ27 for XCSA, XCSB, XCSC). One blanking plug is delivered with the product. Not recommended for use in saline atmospheres.

Safety detection solutions

Key-operated safety switches

XCSPA, XCSB and XCSC metal, turret head

XCSPMP, XCSPA and XCSTA

plastic, double insulated, turret head

Contact block characteristics		
Rated operational characteristics	2 and 3 contacts, slow break	XCSPA, XCSB, XCSC, XCSTA, XCSPA: ~ AC-15, A300: $U_e = 240\text{ V}$, $I_e = 3\text{ A}$ or $U_e = 120\text{ V}$, $I_e = 6\text{ A}$ XCSPMP: ~ AC-15, C300: $U_e = 240\text{ V}$, $I_e = 0.75\text{ A}$ or $U_e = 120\text{ V}$, $I_e = 1.5\text{ A}$ All models: --- DC-13, Q300: $U_e = 250\text{ V}$, $I_e = 0.27\text{ A}$ or $U_e = 125\text{ V}$, $I_e = 0.55\text{ A}$ conforming to EN/IEC 60947-5-1
	2 contacts, snap action	XCSPA: ~ AC-15, A300: $U_e = 240\text{ V}$, $I_e = 3\text{ A}$ --- DC-13, Q300: $U_e = 250\text{ V}$, $I_e = 0.27\text{ A}$ or $U_e = 125\text{ V}$, $I_e = 0.55\text{ A}$ conforming to EN/IEC 60947-5-1
	3 contacts, snap action	XCSPA: ~ AC-15, B300: $U_e = 240\text{ V}$, $I_e = 1.5\text{ A}$ --- DC-13, R300: $U_e = 250\text{ V}$, $I_e = 0.1\text{ A}$ or $U_e = 125\text{ V}$, $I_e = 0.55\text{ A}$ conforming to EN/IEC 60947-5-1
Conventional thermal current in enclosure		
XCSPA, XCSB, XCSC, XCSTA (3 slow break contacts): $I_{the} = 10\text{ A}$ XCSPA (2 slow break and snap action contacts): $I_{the} = 10\text{ A}$ XCSPA (3 slow break and snap action contacts): $I_{the} = 6\text{ A}$ XCSPMP (2 and 3 slow break contacts): $I_{the} = 2.5\text{ A}$		
Rated insulation voltage	2 and 3 contacts	3 contacts (XCSPA, XCSB, XCSC, XCSTA), 2 contacts (XCSPA), 2 and 3 contacts (XCSPMP): $U_i = 500\text{ V}$ conforming to EN/IEC 60947-1; $U_i = 300\text{ V}$ conforming to UL 508, CSA C22-2 no. 14
	3 contacts	XCSPA: $U_i = 400\text{ V}$ degree of pollution 3 conforming to EN/IEC 60947-1 $U_i = 300\text{ V}$ conforming to UL 508, CSA C22-2 no. 14
Rated impulse withstand voltage	2 and 3 contacts	3 contacts (XCSPA, XCSB, XCSC, XCSTA), 2 contacts (XCSPA), 2 and 3 contacts (XCSPMP): $U_{imp} = 6\text{ kV}$ conforming to EN/IEC 60947-5-1
	3 contacts	XCSPA: $U_{imp} = 4\text{ kV}$ conforming to EN/IEC 60947-5-4
Positive operation		
NC contacts with positive opening operation conforming to EN/IEC 60947-5-1, Section 3		
Resistance across terminals		
$\leq 30\text{ m}\Omega$ conforming to EN/IEC 60947-5-4		
Short-circuit protection	2 and 3 contacts	3 contacts (XCSPA, XCSB, XCSC, XCSTA), 2 contacts (XCSPA), 2 and 3 contacts (XCSPMP): 10 A cartridge fuse type gG (gl)
	3 contacts	XCSPA: 6 A cartridge fuse type gG (gl)
Connection	Pre-cabled	4 x 0.5 mm ² or 6 x 0.5 mm ² (XCSPMP). PVC
	Screw clamp terminals	XCSPA, XCSTA: Clamping capacity, min: 1 x 0.34 mm ² , max: 2 x 1.5 mm ²
	2 and 3 contacts	3 contacts (XCSPA, XCSB, XCSC, XCSTA), 2 contacts (XCSPA): Clamping capacity, min: 1 x 0.5 mm ² , max: 2 x 1.5 mm ² with or without cable end
3 contacts	XCSPA: clamping capacity, min: 1 x 0.34 mm ² , max: 1 x 1 mm ² or 2 x 0.75 mm ²	

Electrical durability

- Conforming to EN/IEC 60947-5-1 Appendix C
- Utilization categories AC-15 and DC-13
- Maximum operating rate: 3600 operating cycles/hour
- Load factor: 0.5

Only applicable to **XCSPMP**:

- Conforming to EN/IEC 60947-5-1 Appendix C
- Utilization categories AC-15 and DC-13
- Maximum operating rate: 900 operating cycles/hour

XCSPA 2 snap action contact version

AC supply
50/60 Hz ~
~m. inductive circuit

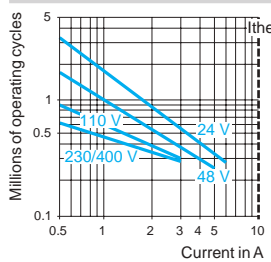

Voltage	V	24	48	120
~m.	W	10	7	4

DC supply ---
Power broken in W for
1 million operating cycles

XCSPA, XCSB, XCSC, XCSTA 3 slow break contact version and XCSPA 2 slow break contact version

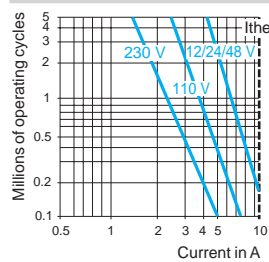

Voltage	V	24	48	120
~m.	W	13	9	7

For **XE2SP•151** on ~ or ---, NC and NO contacts simultaneously loaded to the values shown with reverse polarity.

XCSPA 3 snap action contact version

AC supply
50/60 Hz ~
~m. inductive circuit

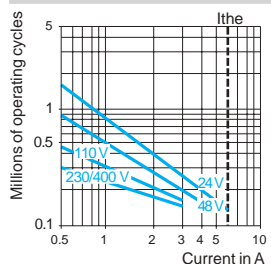

Voltage	V	24	48	120
~m.	W	3	2	1

DC supply ---
Power broken in W for
5 million operating cycles.

XCSPA 3 slow break contact version

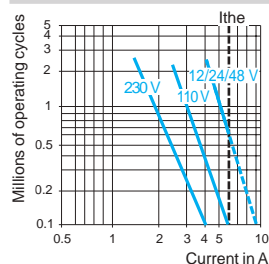

Voltage	V	24	48	120
~m.	W	4	3	2

Safety detection solutions

Key-operated safety switches

XCSMP plastic, fixed head

Pre-cabled, length 2 m, 5 m or 10 m

Type of switch Without locking of actuating key



XCSMP switch

References of switches without actuating key (4) (⊖ NC contact with positive opening operation) (1) (3)

2-pole 1 NC + 1 NO break before make, slow break (2)		XCSMP59L● ⊖
2-pole 2 NC slow break (2)		XCSMP79L● ⊖
3-pole 2 NC + 1 NO break before make, slow break (2)		XCSMP70L● ⊖
3-pole 3 NC slow break (2)		XCSMP80L● ⊖
Weight (kg)		0.110

Complementary characteristics not shown under general characteristics (page 40)

Actuation speed	Maximum: 1.5 m/s, minimum: 0.05 m/s
Mechanical durability	> 1 million operating cycles
Pre-cabled connection	4 x 0.5 mm ² or 6 x 0.5 mm ²
Maximum operating rate	For maximum durability: 1 200 operating cycles per hour
Minimum force for extraction of actuating key	≥ 8 N

References of actuating keys

Description	Straight actuating key	Right-angled actuating key	Pivoting actuating key	
			For right-hand door	For left-hand door



For XCSMP safety switches	XCSZ81	XCSZ84	XCSZ83	XCSZ85
Weight (kg)	0.015	0.025	0.085	0.085

Separate components

Description	Unit reference	Weight kg
Blanking plugs for operating head slot (Sold in lots of 10)	XCSZ29	0.005

(1) Blanking plug for operating head slot included with switch.
 (2) Schematic diagrams shown represent the contact states while the actuating key is inserted in the head of the switch.
 (3) Basic reference, to be completed: replace the dot with 2 for a 2 m long cable, with 5 for a 5 m long cable or with 10 for a 10 m long cable. Some lengths may not be available. Example: XCSMP70L● becomes XCSMP70L10 for a switch with a 10 m long cable.
 (4) Actuating keys to be ordered separately (see above).

Safety detection solutions

Key-operated safety switches

XCSMP plastic, fixed head

Pre-cabled, length 2 m, 5 m or 10 m

Dimensions

XCSMP

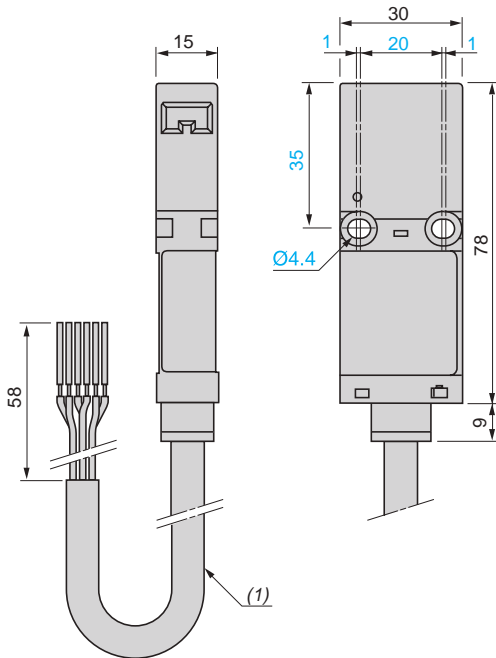

(1) Ø 7.6, length 2, 5 or 10 m.

XCSZ81

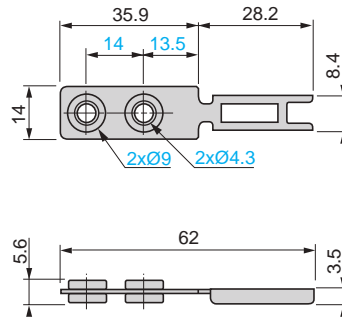

XCSZ84

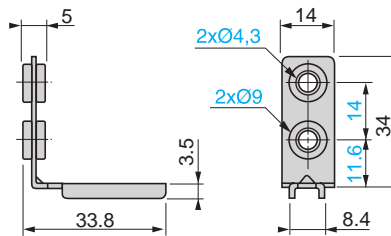

XCSZ83

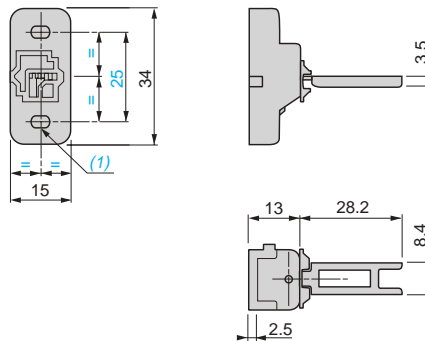

(1) 2 elongated holes Ø 4.2 x 6.

XCSZ85

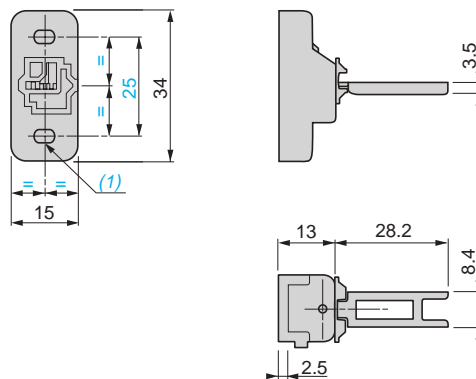

(1) 2 elongated holes Ø 4.2 x 6.

Safety detection solutions

Key-operated safety switches

XCSMP plastic, fixed head

Pre-cabled, length 2 m, 5 m or 10 m

Operating radius required for actuating key

XCSZ81

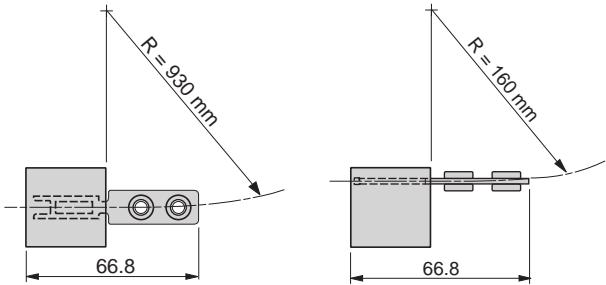

XCSZ84

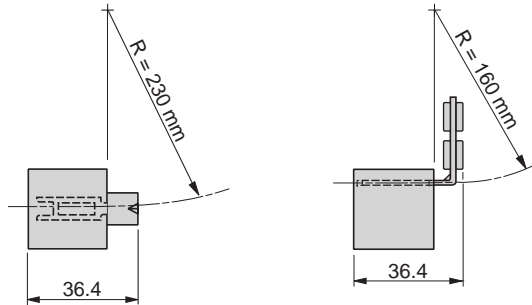

XCSZ83

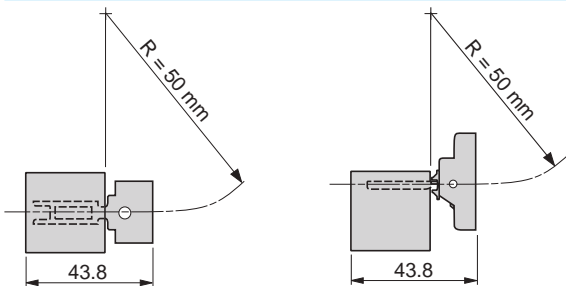

XCSZ85

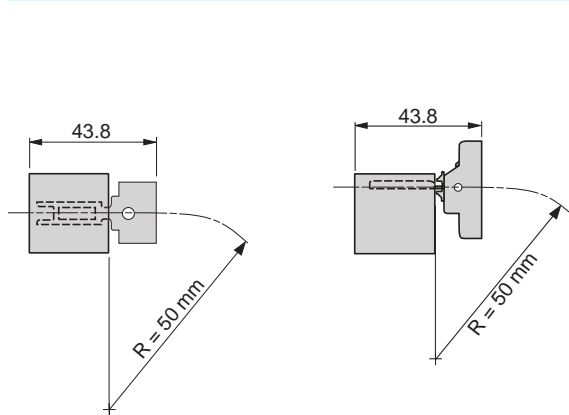

Functional diagrams

XCSMP59●

XCSMP79●

XCSMP70●

XCSMP80●

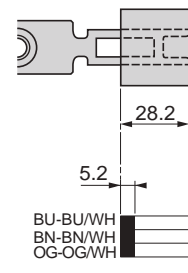
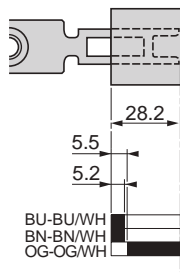
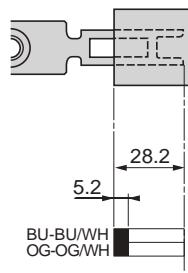
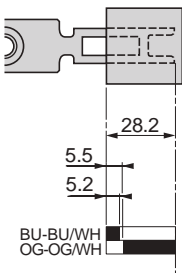

Contact operation

■ closed
□ open

Schemes Note: These schemes are given as examples only, the designer should refer to the relevant safety standards for guidance.

Wiring up to PL=b, category 1 conforming to EN/ISO 13849-1

Example with 3-pole 2 NC + 1 NO contact and protection fuse to help prevent shunting of the NC contact, due to either cable damage or tampering.

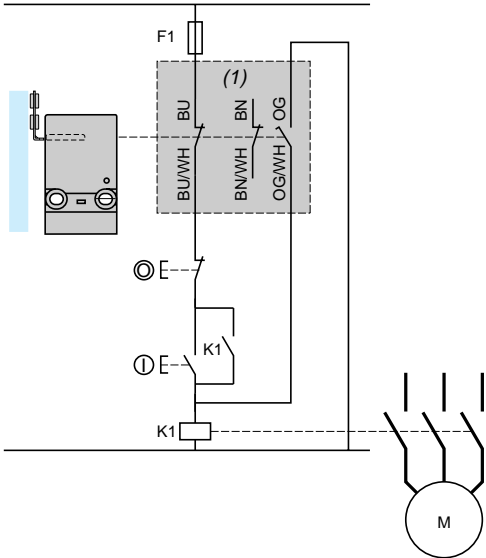

(1) Signaling contact

Wiring up to PL=d, category 3 conforming to EN/ISO 13849-1

Example with 2-pole 1 NC + 1 NO contact with mixed redundancy of the contacts and the associated control relays.

To activate K1, it is necessary to remove and re-insert the actuating key when the supply is switched on.

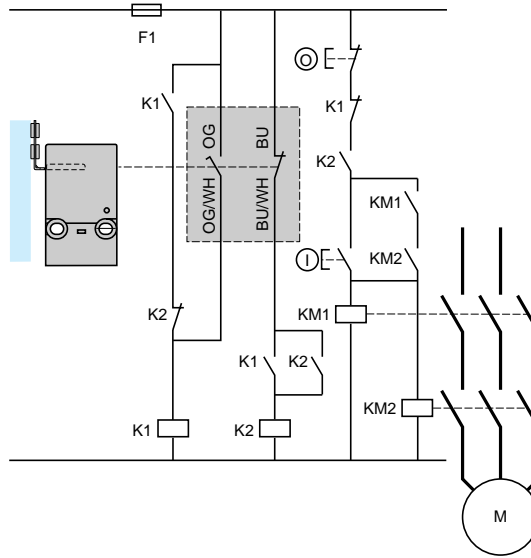

Wiring to PL=e, category 4 conforming to EN/ISO 13849-1 and SIL CL3 conforming to EN/IEC 62061. Wiring method used in conjunction with a safety control unit.

(The guard switch should be used in conjunction with a safety limit switch to give electrical/mechanical redundancy).

Method for machines with quick rundown time (low inertia)

Locking or interlocking device based on the principle of redundancy and self-monitoring. The safety control units provide these functions.

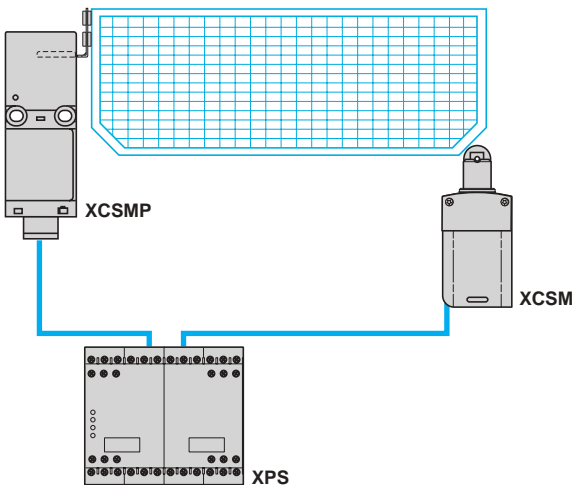

Locking of actuating key and operation in positive mode associated with a safety control unit.

Safety detection solutions

Key-operated safety switches
XCSPA and XCSTA plastic, turret head
1 or 2 cable entries

Type of switch Without locking of actuating key



XCSPA



XCSTA

References of switches without actuating key (4) (⊖ NC contact with positive opening operation) with 1 or 2 cable entries tapped ISO M16 x 1.5

2-pole 1 NC + 1 NO (2) break before make, slow break		XCSPA592	⊖	-
2-pole 1 NC + 1 NO (2) snap action		XCSPA192	⊖	-
2-pole 1 NO + 1 NC (2) make before break, slow break		XCSPA692	⊖	-
2-pole 2 NC (2) slow break		XCSPA792	⊖	-
2-pole 2 NC (2) snap action		XCSPA292	⊖	-
3-pole 1 NC + 2 NO (2) break before make, slow break		XCSPA892	⊖	XCSTA592 ⊖
3-pole 2 NC + 1 NO (2) break before make, slow break		XCSPA992	⊖	XCSTA792 ⊖
3-pole 2 NC + 1 NO (2) snap action		XCSPA492	⊖	-
3-pole 3 NC (2) slow break		-	-	XCSTA892 ⊖
Weight (kg)		0.110		0.160

References of switches without actuating key (4) (⊖ NC contact with positive opening operation) with 1 or 2 cable entries tapped Pg 11 or 1/2" NPT

To order a switch with 1 or 2 cable entries for Pg 11 cable gland (clamping capacity 7 to 10 mm), replace the last number (2) with 1 in the selected reference. Example: XCSPA592 becomes **XCSPA591** (some Pg 11 references may not be available).
To order a switch with 1 or 2 cable entries for 1/2" NPT conduit (one Pg 11 tapped entry fitted with DE9RA1012 metal adapter), replace the last number (2) with 3 in the selected reference. Example: XCSTA592 becomes **XCSTA593** (some 1/2" NPT references may not be available).

Complementary characteristics not shown under general characteristics (page 40)

Actuation speed	Maximum: 0.5 m/s, minimum: 0.01 m/s
Resistance to forcible withdrawal of actuating key	XCSPA, XCSTA: 10 N (50 N using actuating keys XCSZ12 or XCSZ13 together with guard retaining device XCSZ21)
Mechanical durability	XCSPA, XCSTA: > 1 million operating cycles
Maximum operating rate	For maximum durability: 600 operating cycles per hour
Minimum force for positive opening	≥ 15 N
Cable entry	XCSPA: 1 entry tapped M16 x 1.5 for ISO cable gland. XCSTA: 2 entries tapped M16 x 1.5 for ISO cable gland.
Materials	Body and head: polyamide PA66, fibreglass impregnated

References of accessories

	Description	For use with	Unit reference	Weight kg
 XCSTA91	Blanking plugs for operating head slot (Sold in lots of 10)	XCSPA, XCSTA	XCSZ28	0.050
 XCSTA91	Padlocking device to help prevent insertion of actuating key, for up to 3 padlocks (padlocks not included)	XCSPA, XCSTA	XCSZ91	0.053
 XCSTA200	Actuating key centering device (3) (Fixing screws included)	XCSPA, XCSTA	XCSZ200	0.022

(1) Head adjustable in 90° steps through 360°. Blanking plug for operating head slot included with switch.
(2) Schematic diagrams shown represent the contact states while the actuating key is inserted in the head of the switch.
(3) Not for use with XCSZ91.
(4) Actuating keys to be ordered separately (see page 47).

Other versions: please consult our Customer Care Center.

References of actuating keys and guard retaining device



Description	Straight actuating key	Actuating key with wide fixing (1)		Pivoting actuating key	Right-angled actuating key	Guard retaining device (2)
For XCSPA and XCSTA key-operated safety switches	XCSZ11	XCSZ12	XCSZ15	XCSZ13	XCSZ14	XCSZ21
Weight (kg)	0.015	0.015	0.012	0.085	0.025	0.080

(1) 2 actuating key lengths, XCSZ12: L = 40 mm, XCSZ15: L = 29 mm.

(2) Only for use with XCSPA and XCSTA key-operated switches (without XCSZ200 actuating key centering device) used in conjunction with XCSZ12, XCSZ13 or XCSZ15 actuating keys.

Dimensions

XCSPA●91, XCSPA●92

XCSPA●93

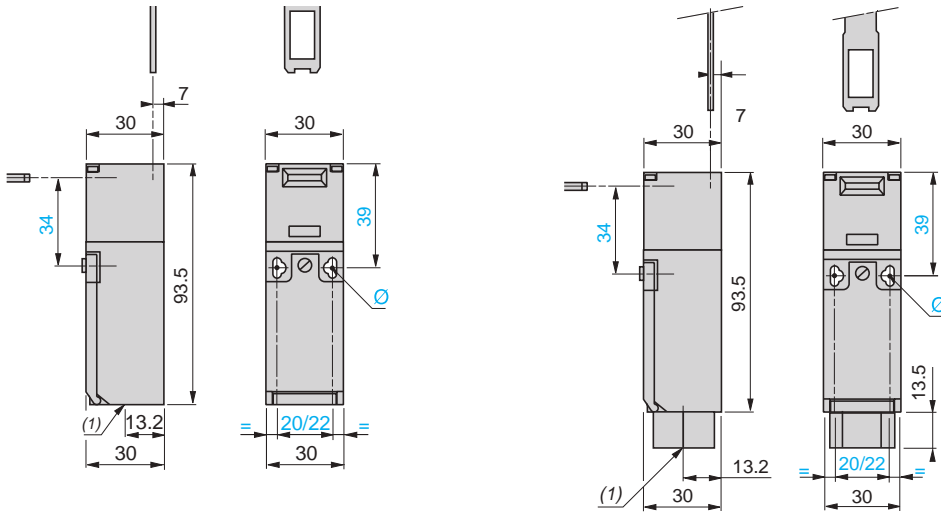

(1) 1 tapped entry for cable gland

Ø: 2 elongated holes Ø 4.3 x 8.3 on 22 centers, 2 holes Ø 4.3 on 20 centers

(1) 1 tapped entry for 1/2" NPT conduit

Ø: 2 elongated holes Ø 4.3 x 8.3 on 22 centers, 2 holes Ø 4.3 on 20 centers

XCSTA●9●

XCSZ200 actuating key centering device

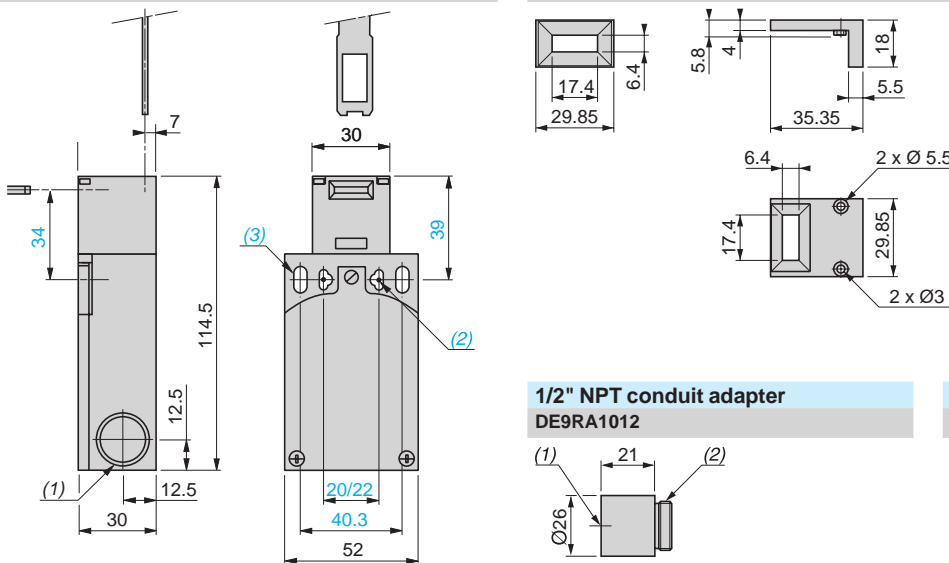

1/2" NPT conduit adapter
DE9RA1012

M16 x 1.5 adapter
DE9RA1016

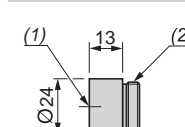
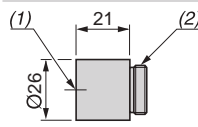

(1) 2 tapped entries for cable gland or 1/2" NPT conduit adapter

(2) 2 elongated holes Ø 4.3 x 8.3 on 22 centers,
2 holes Ø 4.3 on 20 centers

(3) 2 elongated holes Ø 5.3 x 13.3

(1) Tapped entry for 1/2" NPT conduit

(2) Pg 11 threaded shank

(1) M16 x 1.5 tapped entry

(2) Pg 11 threaded shank

Dimensions (continued)

XCSZ11

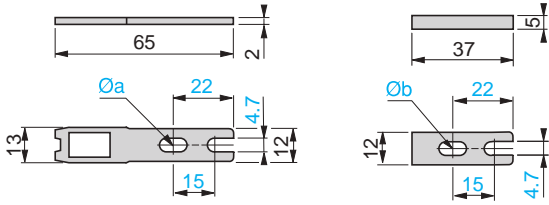

(1) Adapter (included with XCSZ11 actuating key) for replacing, without drilling an additional fixing hole, a legacy XCKP/T key-operated switch with XCKY01 actuating key by an XCSTA key-operated switch with XCSZ11 actuating key.

Ø a: 2 elongated holes Ø 4.7 x 10

Ø b: 1 elongated hole for M4 or M4.5 screw

XCSZ12, XCSZ15

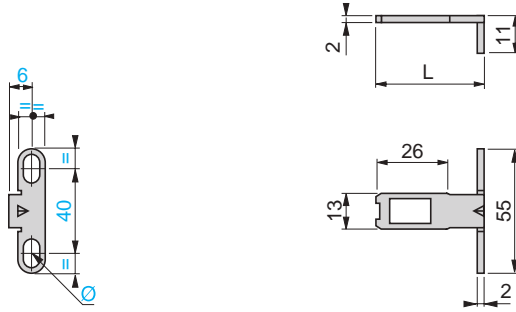

Ø: 2 elongated holes Ø 4.7 x 10

L = 40 mm (XCSZ12) or 29 mm (XCSZ15)

XCSZ13

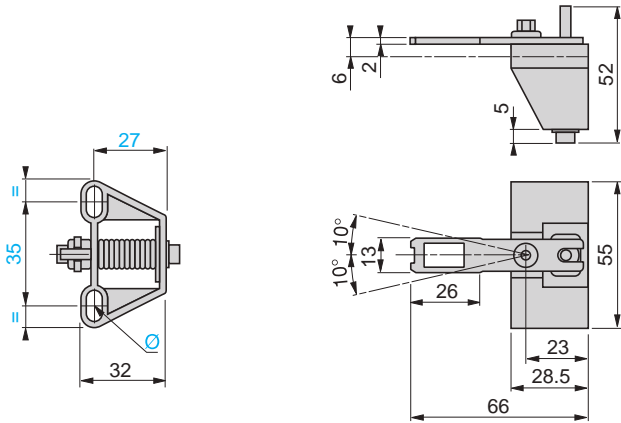

Ø: 2 elongated holes Ø 4.7 x 10

XCSZ14

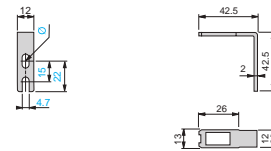

Ø: 1 elongated hole Ø 4.7 x 10

Operating radius required for actuating key

XCSZ11

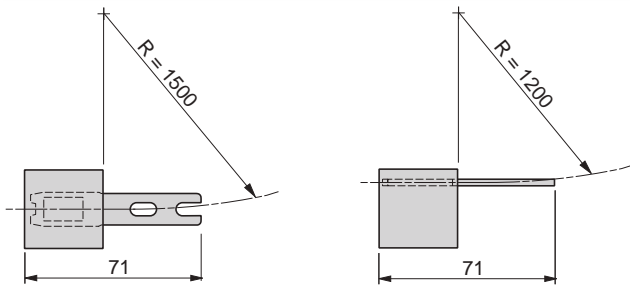

XCSZ12, XCSZ15

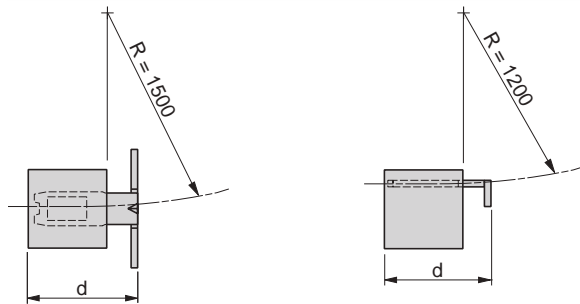

d = 46 mm (XCSZ12) or 35 mm (XCSZ15)

XCSZ13

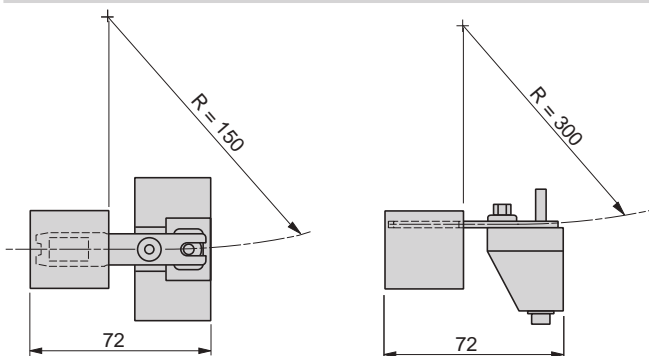

XCSZ14

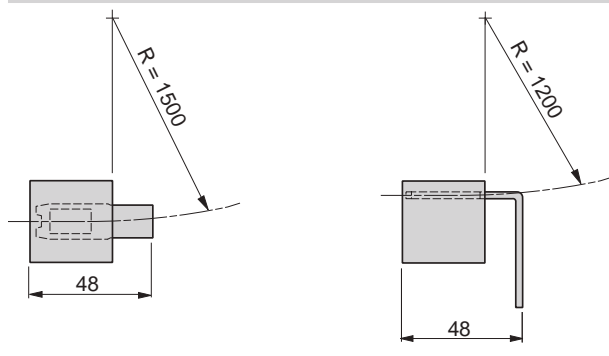

R = minimum radius

Setting-up

Functional diagrams

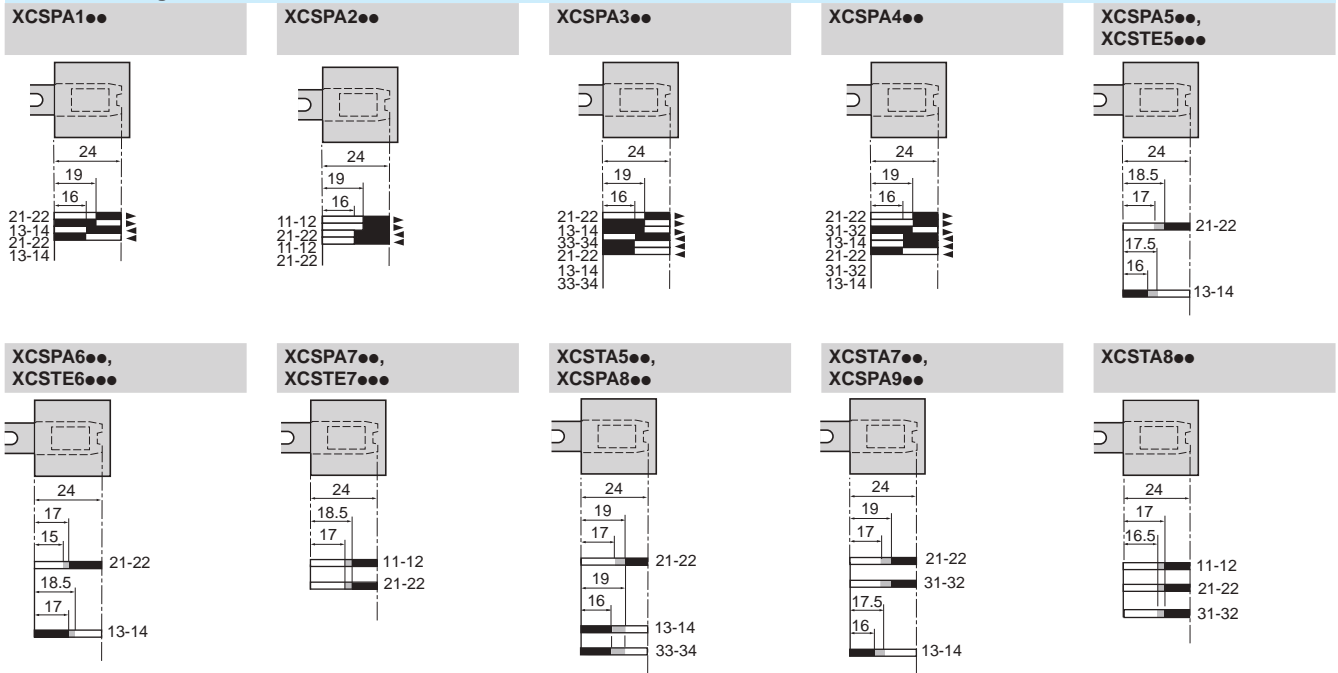

Contact operation

Closed
 Open
 Transient state

Schemes Note: These schemes are given as examples only, the designer should refer to the relevant safety standards for guidance.

Wiring to PL=e, category 4 conforming to EN/ISO 13849-1 and SIL CL3 conforming to EN/IEC 62061
Wiring method used in conjunction with a safety control unit

(The key-operated switch should be used in conjunction with a safety limit switch to give electrical/mechanical redundancy)

Method for machines with quick rundown time (low inertia)

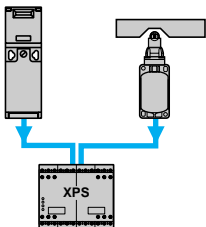

Locking of actuating key and operation in positive mode associated with a safety control unit.

Wiring to PL=b, category 1 conforming to EN/ISO 13849-1

Example with 3-pole 1 NC + 2 NO contact and protection fuse to help prevent shunting of the NC contact, due to either cable damage or tampering.

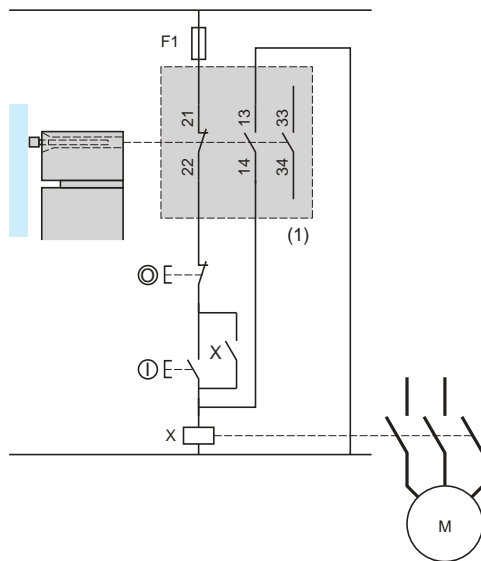

(1) Signaling contact.

Wiring to PL=d, category 3 conforming to EN/ISO 13849-1

Example with 2-pole 1 NC + 1 NO contact with mixed redundancy of the contacts and the associated control relays. To activate K1, it is necessary to remove and re-insert the actuating key when the supply is switched on.

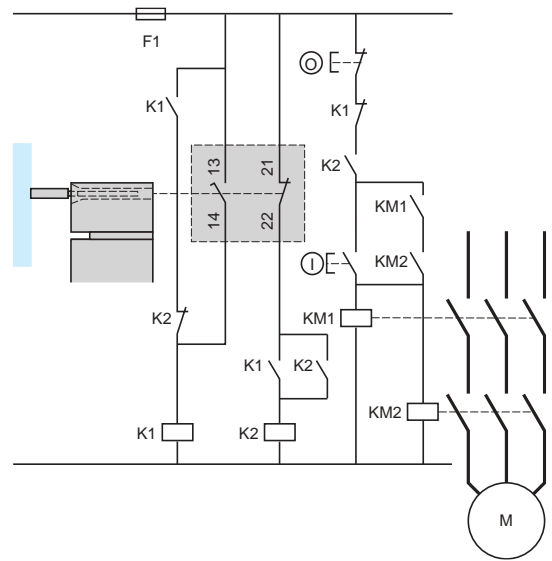



Safety detection solutions

Key-operated switches

XCSA, XCSB and XCSC metal, turret head (1)

1 cable entry

Type of switch	Without locking of actuating key		With locking of actuating key, manual unlocking (2)	
				
	XCSA		XCSB	XCSC

LED indication on opening of NC contacts	No	1 orange LED 24/48 V ~	1 orange LED 110/240 V ~	No (4)	No (4)
--	----	------------------------	--------------------------	--------	--------

References of switches without actuating key (5) (⊖ NC contact with positive opening operation) with 1 cable entry tapped ISO M20 x 1.5

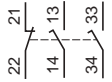
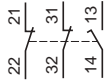
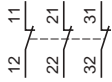
3-pole 1 NC + 2 NO break before make, slow break (3)		XCSA502 ⊖	XCSA512 ⊖	XCSA522 ⊖	XCSB502 ⊖	XCSC502 ⊖
3-pole 2 NC + 1 NO break before make, slow break (3)		XCSA702 ⊖	XCSA712 ⊖	XCSA722 ⊖	XCSB702 ⊖	XCSC702 ⊖
3-pole 3 NC slow break (3)		XCSA802 ⊖	-	-	XCSB802 ⊖	XCSC802 ⊖
Weight (kg)	0.440	0.440	0.440	0.475	0.480	

References of switches without actuating key (5) with 1 cable entry tapped Pg 13.5

To order a switch with a Pg 13.5 cable entry, replace the last number (2) with 1 in the selected reference.
Example: XCSA502 becomes XCSA501 (some Pg 13.5 references may not be available).





References of switches without actuating key (5) with 1 cable entry tapped 1/2" NPT

To order a switch with a 1/2" NPT cable entry, replace the last number (2) with 3 in the selected reference.
Example: XCSA502 becomes XCSA503 (some 1/2" NPT references may not be available).

Complementary characteristics not shown under general characteristics (page 40)

Actuation speed	Maximum: 0.5 m/s, minimum: 0.01 m/s
Resistance to forcible withdrawal of actuating key (locked)	XCSB and XCSC: $F_{1max} = 1500\text{ N}$; $F_{2h} = 1150\text{ N}$
Mechanical durability	XCSA: > 1 million operating cycles XCSB and XCSC: 0.6 million operating cycles
Maximum operating rate	For maximum durability: 600 operating cycles per hour
Minimum force for extraction of actuating key (not locked)	≥ 20 N
Cable entry	XCSA, XCSB, XCSC: 1 cable entry Entry tapped ISO M20 x 1.5, clamping capacity 7 to 13 mm
Materials	Body: Zamak. Head: Zamak. Safety screws: 5-lobe torque. Protective plate: steel.

References of actuating keys

				
Description	Straight actuating key	Actuating key with wide fixing	Pivoting actuating key	Latch for sliding doors
For XCSA, XCSB or XCSC key-operated switches	XCSZ01	XCSZ02	XCSZ03	XCSZ05
Weight (kg)	0.020	0.020	0.095	0.600

(1) Head adjustable in 90° steps through 360°. Blanking plug for operating head slot included with switch.

(2) Unlocking by pushbutton for XCSB●●● and by key-operated lock for XCSC●●● (2 keys included with switch).

(3) Schematic diagrams shown represent the contact states while the actuating key is inserted in the head of the switch.

(4) 1 orange LED 24/48V ~ indicator available with the XCSZ31 accessory

1 orange LED 110/240V ~ indicator available with the XCSZ32 accessory

(5) Actuating keys to be ordered separately (see above).

Other versions: please consult our Customer Care Center.

Safety detection solutions

Key-operated switches

XCSA, XCSB and XCSC metal, turret head

1 cable entry

Separate components



XCSZ31

Description	For use with	Supply voltage	Reference	Weight kg
1 kit including: - 1 orange LED indicator module - 1 cover - Seal - 2 fixing screws	XCSA	~ or 24/48 V $\overline{\text{---}}$	XCSZ31	0.040
		110/240 V ~	XCSZ32	0.040

Description	For use with	Unit reference	Weight kg
Blanking plugs for operating head slot (Sold in lots of 10)	XCSA, XCSB, XCSC	XCSZ27	0.050

Description	For use with	Unit reference	Weight kg
Keys for forced opening of interlocking device (Sold in lots of 10)	XCSB, XCSC	XCSZ25	0.100



XCSZ90

Description	For use with	Unit reference	Weight kg
Padlocking device helps to prevent insertion of actuating key, for up to 3 padlocks (padlocks not included)	XCSA, XCSB, XCSC	XCSZ90	0.055

Dimensions

Key-operated switches

XCSA●●●

XCSB●●●, XCSC●●●

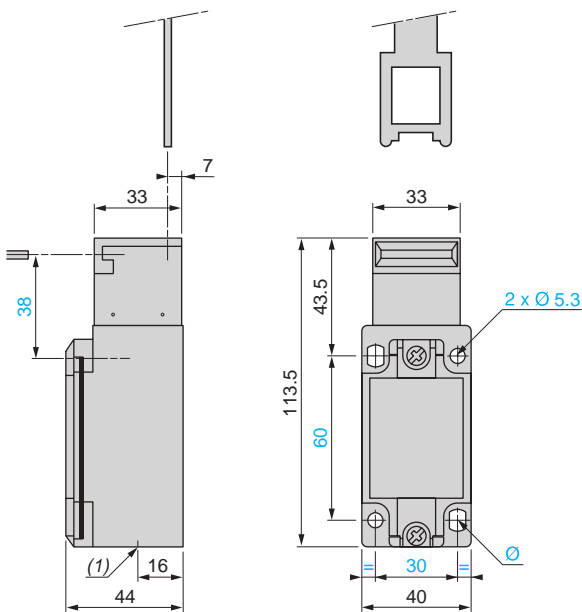

(1) 1 tapped entry for cable gland
Ø: 2 elongated holes Ø 5.3 x 7.3

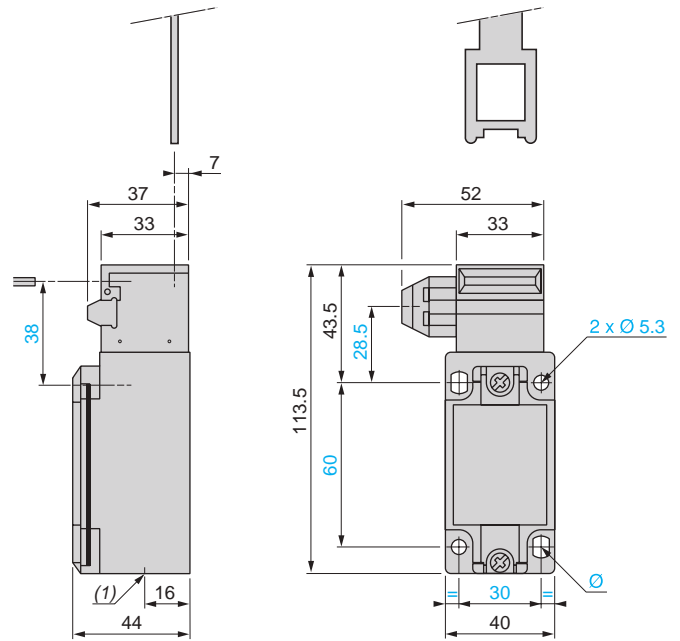

(1) 1 tapped entry for cable gland
Ø: 2 elongated holes Ø 5.3 x 7.3

Safety detection solutions

Key-operated switches

XCSA, XCSB and XCSC metal, turret head

1 cable entry

Actuating keys

XCSZ01

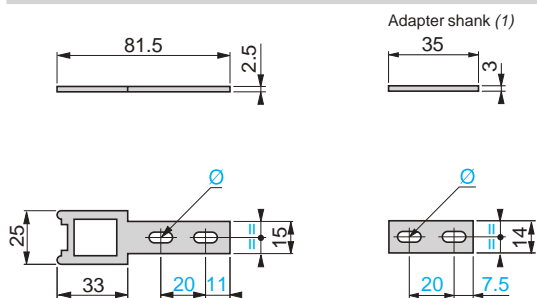

XCSZ02

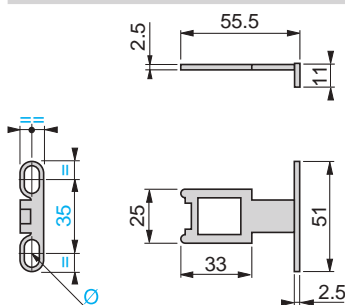

(1) Adapter (included with XCSZ01 actuating key) for replacing, without drilling an additional fixing hole, an XCKJ guard switch with ZCKY07 actuating key by an XCSA, XCSB or XCSC guard switch with XCSZ01 actuating key.

Ø: 2 elongated holes Ø 5.3 x 10

Ø: 2 elongated holes Ø 5.3 x 10

XCSZ03

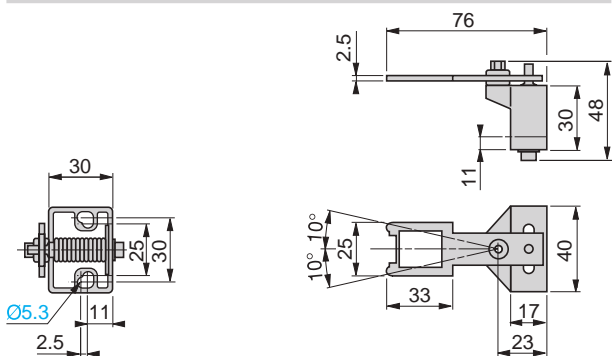

XCSZ05

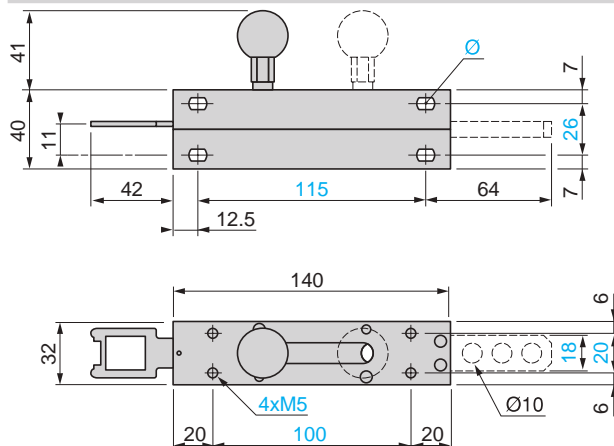

Fixing axis % related to actuating key.

Ø: 4 elongated holes Ø 5.3 x 7.3

Operating radius required for actuating key

XCSZ01

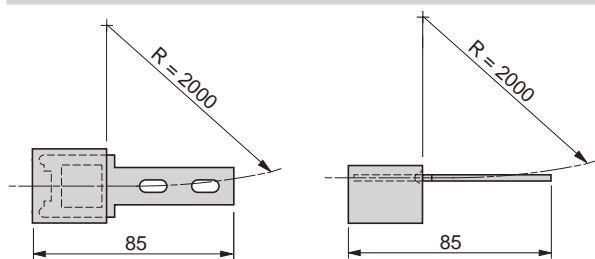

XCSZ02

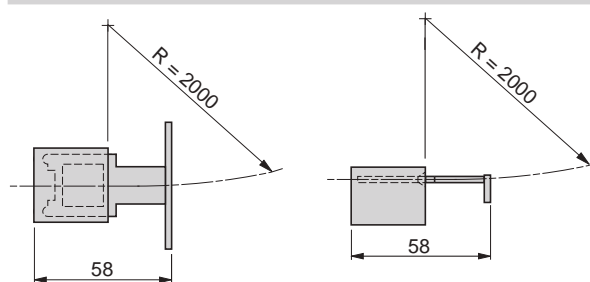

XCSZ03

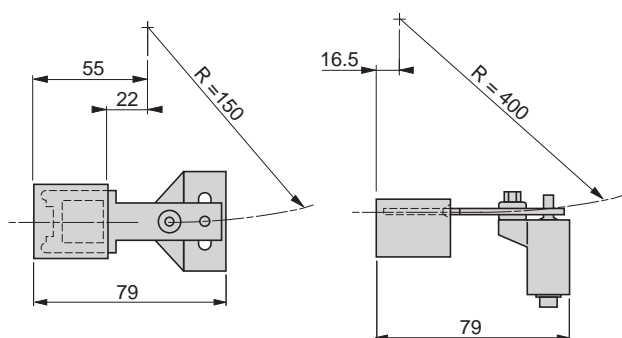

R = minimum radius

Setting-up

Functional diagrams

XCS•5•••

XCS•7•••

XCS•8•••

Contact operation

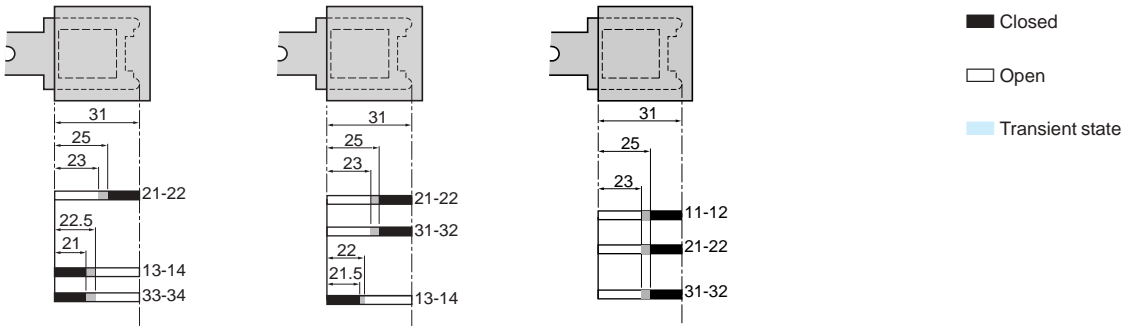

Schemes Note: These schemes are given as examples only, the designer should refer to the relevant safety standards for guidance.

Wiring up to PL=b, category 1 conforming to EN/SO 13849-1

Example with 3-pole 1 NC + 2 NO contact and protection fuse to help prevent shunting of the NC contact, due to either cable damage or tampering.

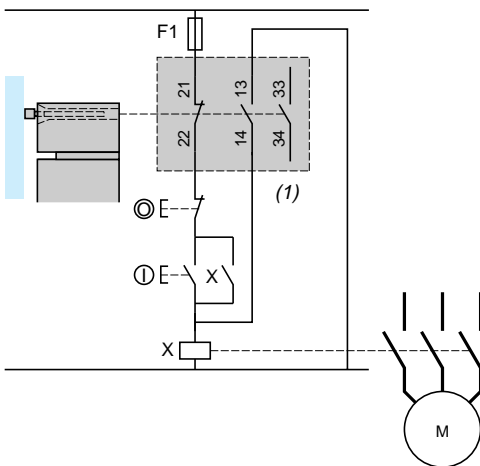

(1) Signaling contact

Wiring up to PL=d, category 3 conforming to EN/ISO 13849-1

Example with 3-pole 1 NC + 2 NO contact with mixed redundancy of the contacts and the associated control relays. To activate K1, it is necessary to remove and re-insert the actuating key when the supply is switched on.

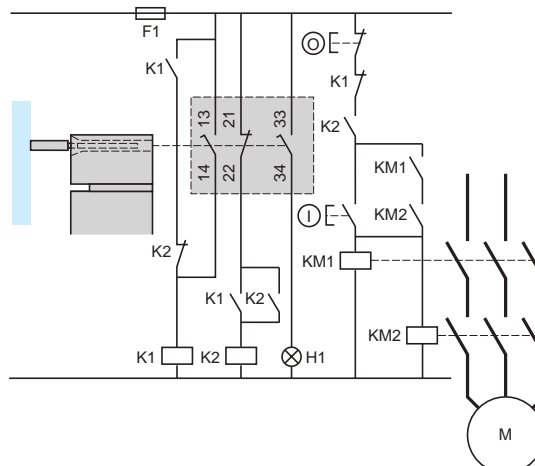

H1: "Actuating key not inserted" indicator

Wiring to PL=e, category 4 conforming to EN/ISO 13849-1 and SIL CL3 conforming to EN/IEC 62061. Wiring method used in conjunction with a safety control unit.

(The key-operated switch should be used in conjunction with a safety limit switch to give electrical/mechanical redundancy).

Method for machines with quick rundown time (low inertia)

Locking device based on the principle of redundancy and self-monitoring. The safety control units provide these functions.

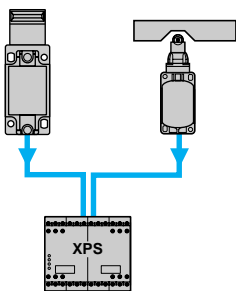

Locking of actuating key and operation in positive mode associated with a safety control unit.

Safety detection solutions

Safety interlock switches
Key-operated with solenoid, turret head
XCSLF and XCSLE slim design

XCSLF metal

Safety interlock switches operated by actuating key

With emergency release mushroom head pushbutton



Pages 56 and 57

Pages 58 and 59

XCSLE plastic

Safety interlock switches operated by actuating key



Pages 60 and 61

Environmental characteristics			
Safety interlock switch type		XCSLF (metal)	XCSLE (plastic)
Conformity to standards	Products	EN/IEC 60947-5-1, EN/ISO 13849-1, EN/IEC 62061, UL 508, CSA C22-2 no. 14	
	Machine assemblies	EN/IEC 60204-1, EN/ISO 14119, EN/ISO 12100	
Product certifications		UL, CSA, CCC, EAC	
Maximum safety level (1)		PL=e, category 4 conforming to EN/ISO 13849-1 and SIL CL3 conforming to EN/IEC 62061	
Reliability data B _{10D}		5,500,000 (value given for a service life of 20 years, limited by mechanical or contact wear)	
Ambient air temperature	For operation	-25 ...+60 °C	
	For storage	-40...+70 °C	
Vibration resistance		5 gn (10...500 Hz) conforming to EN/IEC 60068-2-6	
Shock resistance		10 gn (duration 11 ms) conforming to EN/IEC 60068-2-27	
Electric shock protection	Conforming to EN/IEC 61140	Class I (cable entries)	Class II (cable entries)
		Class I (M23 connector, 19 pins)	
Degree of protection		IP 65 (XCSL●●●●●M3, versions with M23 connector) IP 66 and IP 67 (IP 66 for XCSLF●●●●4●● and for XCSLF●●●●6●●) conforming to EN/IEC 60529 and EN/IEC 60947-5-1 (2)	
Connection		3 cable entries tapped M20 x 1.5 for ISO cable gland. Clamping capacity 7 to 13 mm or entries tapped for 1/2" NPT conduit or M23 19-pin connector output (18+1PE) 24 V --- versions.	
Material		Zamak case	Polyamide case
		Actuating keys (all types): steel XC60, surface treated	

(1) Using an appropriate and correctly connected safety control unit.

(2) Live parts of these switches are protected to some extent against the penetration of dust and water. However, when installing take all necessary precautions to help prevent the penetration of solid bodies, or liquids with a high dust content, into the actuating key aperture. Use of XCSZ30 blanking plugs for unused key slots can reduce the penetration of unwanted elements (one blanking plug is delivered with the product). Not recommended for use in saline atmospheres.

Safety detection solutions

Safety interlock switches
Key-operated with solenoid, turret head
XCSLF and XCSLE slim design

Contact block characteristics		
Safety interlock switch type	XCSLF●●●●●12 and XCSLE●●●●●12 (versions with 3 cable entries)	XCSLF●●●●●M3 and XCSLE●●●●●M3 (versions with M23 connector)
Rated operational characteristics	AC-15 ~, C300: $U_e = 240\text{ V}$, $I_e = 0.75\text{ A}$ DC-13 ---, R300: $U_e = 250\text{ V}$, $I_e = 0.1\text{ A}$ conforming to EN/IEC 60947-5-1	~ AC-15, C300: $U_e = 24\text{ V}$, $I_e = 1.5\text{ A}$ --- DC-13, R300: $U_e = 24\text{ V}$, $I_e = 0.22\text{ A}$ conforming to EN/IEC 60947-5-1
Conventional thermal current in enclosure	$I_{the} = 4\text{ A}$ (sum of the thermal currents $\leq 15\text{ A}$)	
Rated insulation voltage	$U_i = 250\text{ V}$ degree of pollution 3 conforming to EN/IEC 60947-1 $U_i = 300\text{ V}$ conforming to UL 508, CSA C22-2 no. 14	$U_i = 60\text{ V}$ degree of pollution 3 conforming to EN/IEC 60947-1 $U_i = 50\text{ V}$ conforming to UL 508, CSA C22-2 no. 14
Rated impulse withstand voltage	$U_{imp} = 4\text{ kV}$ conforming to EN/IEC 60947-1	$U_{imp} = 0.8\text{ kV}$ conforming to EN/IEC 60947-1
Positive operation	Contacts with positive opening operation conforming to EN/IEC 60947-5-1	
Minimum switching current	10 mA at 20 V	
Minimum switching voltage	17 V	
Short-circuit protection	4 A cartridge fuse gG (gl) or 6 A fast-blow fuse	
Connection	Clamping capacity on spring terminals: 2 x 0.5 mm ² stripped flexible cables, 13 mm long 1 x 1.5 mm ² flexible or rigid cable	
Additional characteristics		
Actuation speed	Maximum: 0.5 m/s, minimum: 0.01 m/s	
Resistance to forcible withdrawal of actuating key (locked)	XCSLF: $F_{1max} = 3000\text{ N}$, $F_{Zh} = 2300\text{ N}$ XCSLE: $F_{1max} = 1400\text{ N}$, $F_{Zh} = 1100\text{ N}$	
Shock resistance	XCSLE: 1.2 J max. or 4.9 J depending on installation (see page 22) XCSLF: 6.4 J max. or 9.6 J (see page 22)	
Mechanical durability	XCSLF and XCSLE: > 1 million operating cycles Emergency release mushroom head pushbutton on XCSLF: 30,000 operating cycles	
Maximum operating rate	For maximum durability: 600 operating cycles per hour	
Minimum force for extraction of actuating key (not locked)	$\geq 20\text{ N}$	

Additional characteristics (continued)

Electrical durability

AC supply
50/60 Hz ~
~m inductive circuit

- Conforming to EN/IEC 60947-5-1 Appendix C
- Utilization categories AC-15 and DC-13
- Maximum operating rate: 3,600 operating cycles/hour
- Load factor: 0.5

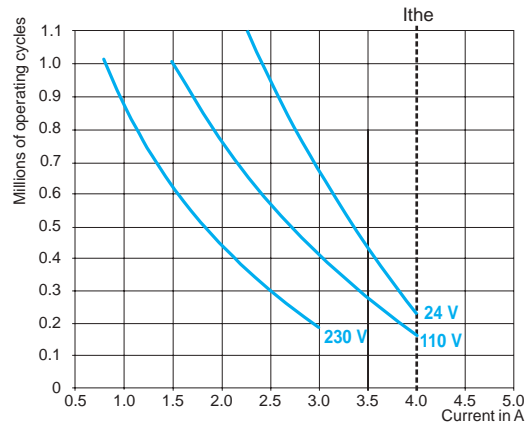

DC supply ---
Power broken for 1 million
operating cycles

Voltage	V	24	48	120
~m	W	16	28	38

Switching capacity

- Conforming to EN/IEC 60947-5-1 Appendix C
- Utilization categories AC-15 and DC-13

Switching capacity 1:
C300 240 V 0.75 A
R300 250 V 0.1 A

Switching capacity 2:
C300 120 V 1.5 A
R300 125 V 0.22 A

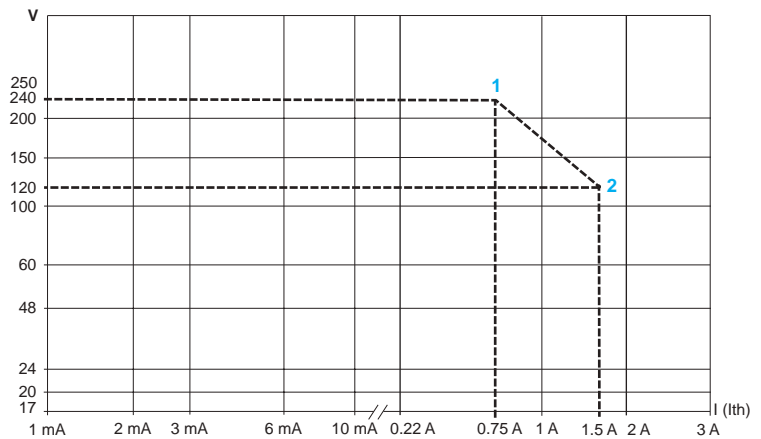

Safety detection solutions

Safety interlock switches

Key-operated with solenoid, turret head (1)

XCSLF metal, 3 cable entries

Type of switch

Locking on de-energization and unlocking on energization of solenoid (2)



LED indication

Orange LED: "guard open" indication
Green LED: "guard closed and locked" indication

Power supply for the solenoid and the LEDs

24 V $\overline{\text{---}}$ or \sim (50/60 Hz on \sim)

Type of auxiliary contact actuated by the solenoid (locking contacts).

Contact states represented with actuating key inserted and solenoid not energized.

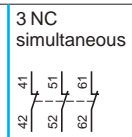
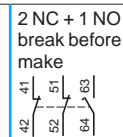
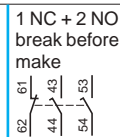
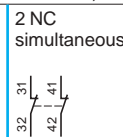
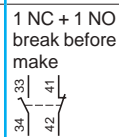

References of switches without actuating key (3) (⊖ NC contact with positive opening operation)

Types of main contact actuated by the key

Contact states represented with actuating key inserted

With 3 cable entries tapped ISO M20 x 1.5

2-pole contact 1 NC + 1 NO break before make, slow break		XCSLF2525312 ⊖	—	—	—	—
2-pole contact 2 NC simultaneous, slow break		XCSLF2725312 ⊖	XCSLF2727312 ⊖	—	—	—
3-pole contact 1 NC + 2 NO break before make, slow break		—	—	XCSLF3535312 ⊖	—	—
3-pole contact 2 NC + 1 NO break before make, slow break		—	—	—	XCSLF3737312 ⊖	—
3-pole contact 3 NC simultaneous, slow break		—	—	—	—	XCSLF3838312 ⊖
Weight (kg)		1.100	1.100	1.100	1.100	1.100

Solenoid and LED characteristics

Load factor	100%
Rated operational voltage (4)	24 V $\overline{\text{---}}$ or \sim or 120 V \sim or 230 V \sim
Voltage limits	Conforming to EN/IEC 60947-1 - 15%, + 10% of the rated operational voltage (including ripple on $\overline{\text{---}}$)
Consumption	< 5.4 W at 20 °C and max. voltage

References of complete switches with solenoid supply voltage of 120 V or 230 V

To order a switch with a solenoid voltage of 110/120 V \sim , replace the sixth number in the selected reference with 3.

Example: XCSLF3535312 becomes **XCSLF3535332**. Some 110/120V \sim references may not be available.

To order a switch with a solenoid voltage of 220/240 V \sim , replace the sixth number in the selected reference with 4.

Example: XCSLF3535312 becomes **XCSLF3535342**. Some 220/240V \sim references may not be available.

References of switches with locking on energization and unlocking on de-energization

To order a safety interlock switch with locking on energization and unlocking on de-energization of the solenoid, replace the fifth number in the selected reference with 5. For these models, the auxiliary contact states are represented with key inserted and solenoid energized.

Example: XCSLF3535312 becomes **XCSLF3535512**. Some references with locking on energization may not be available.

References of complete switches with 3 cable entries tapped for 1/2" NPT conduit

To order a switch with three 1/2" NPT cable entries, replace the last number in the reference with 3.

Example: XCSLF3535312 becomes **XCSLF3535313**. Some 1/2" NPT references may not be available.

References of actuating keys and separate parts

See page 64.

(1) Head adjustable in 90° steps through 360°. Blanking plug for operating head slot included with switch.

(2) A key-operated lock (2 keys included with switch) enables forced opening of the interlocking mechanism by authorized personnel, allowing withdrawal of the actuating key and subsequent opening of the NC safety contacts (auxiliary release).

(3) Actuating keys to be ordered separately (see page 64).

(4) Common power supply for the solenoid and the LEDs.

Other versions: consult your Customer Care Center.

Safety detection solutions

Safety interlock switches

Key-operated with solenoid, turret head (1)

XCSLF metal, connector output

Type of switch Locking on de-energization and unlocking on energization of solenoid (2)



LED indication Orange LED: "guard open" indication
Green LED: "guard closed and locked" signaling

Power supply for the solenoid and the LEDs 24 V $\overline{\text{---}}$ or \sim (50/60 Hz on \sim)

Type of auxiliary contact actuated by the solenoid (locking contacts). Contact states represented with actuating key inserted and solenoid not energized.	1 NC + 2 NO break before make	2 NC + 1 NO break before make	3 NC simultaneous

References of switches without actuating key (3) (⊖ NC contact with positive opening operation)

Types of main contact actuated by the key

Contact states represented with actuating key inserted

With 19-pin (6 contacts) M23 connector output

3-pole contact 1 NC + 2 NO break before make, slow break		XCSLF353531M3 ⊖	-	-
3-pole contact 2 NC + 1 NO break before make, slow break		-	XCSLF373731M3 ⊖	-
3-pole contact 3 NC simultaneous, slow break		-	-	XCSLF383831M3 ⊖
Weight (kg)		1.100	1.100	1.100

Solenoid and LED characteristics

Load factor	100%
Rated operational voltage (4)	24 V $\overline{\text{---}}$ or \sim
Voltage limits	Conforming to EN/IEC 60947-1 - 15%, + 10% of the rated operational voltage (including ripple on $\overline{\text{---}}$)
Consumption	< 5.4 W at 20 °C and max. voltage

References of switches with locking on energization and unlocking on de-energization

To order a safety interlock switch with locking on energization and unlocking on de-energization of the solenoid, replace the fifth number in the selected reference with 5.

For these models, the auxiliary contact states are represented with key inserted and solenoid energized.

Example: XCSLF373731M3 becomes **XCSLF373751M3**. Some references with locking on energization may not be available.

References of actuating keys and separate parts

See page 64.

(1) Head adjustable in 90° steps through 360°. Blanking plug for operating head slot included with switch.

(2) A key-operated lock (two keys included with switch) enables forced opening of the interlocking mechanism by authorized personnel, allowing withdrawal of the actuating key and subsequent opening of the NC safety contacts (auxiliary release).

(3) Actuating keys to be ordered separately (see page 64).

(4) Common power supply for the solenoid and the LEDs.

Note : Due to existing cable connections and to increase your personal safety, safety screws have been used on the front of the product to help prevent unauthorized access.

Other versions: consult your Customer Care Center.

Safety detection solutions

Safety interlock switches

Key-operated with solenoid, turret head (1)

XCSLF metal, emergency release pushbutton,



3 cable entries

Type of switch	Locking on de-energization and unlocking on energization of solenoid (2) with emergency release by mushroom head pushbutton (3)
----------------	---





LED indication	Orange LED: "guard open" indication Green LED: "guard closed and locked" indication
----------------	--

Power supply for the solenoid and the LEDs	24 V $\overline{\text{---}}$ or \sim (50/60 Hz on \sim)
--	--

Type of auxiliary contact actuated by the solenoid (locking contacts). Contact states represented with actuating key inserted and solenoid not energized.	1 NC + 2 NO break before make 	2 NC + 1 NO break before make 
--	--	--

References of switches without actuating key (4) (⊖ NC contact with positive opening operation)
Types of main contact actuated by the key
Contact states represented with actuating key inserted with trigger action mushroom head pushbutton, diameter 40 mm, "turn to release" reset
With 3 entries tapped ISO M20 x 1.5

3-pole contact 1 NC + 2 NO break before make, slow break 	XCSLF3535412 ⊖	-
3-pole contact 2 NC + 1 NO break before make, slow break 	-	XCSLF3737412 ⊖
Weight (kg)	1.220	1.220

Solenoid and LED characteristics

Load factor	100%
Rated operational voltage (5)	24 V $\overline{\text{---}}$ or \sim or 120 V \sim or 230 V \sim
Voltage limits	Conforming to EN/IEC 60947-1 - 15%, + 10% of the rated operational voltage (including ripple on $\overline{\text{---}}$)
Consumption	< 5.4 W at 20 °C and max. voltage

References of switches with trigger action mushroom head pushbutton, diameter 40 mm, key no. 455 reset

To order a switch with trigger action mushroom head pushbutton, key no. 455 release, diameter 40 mm at the rear of the product, replace the fifth number in the selected reference with 6.
 Example: XCSLF3535412 becomes **XCSLF3535612**. Some references with trigger action mushroom head pushbutton may not be available.

References of complete switches with solenoid supply voltage of 120 V or 230 V

To order a switch with a solenoid voltage of 110/120 V \sim , replace the sixth number in the selected reference with 3.
 To order a switch with a solenoid voltage of 220/240 V \sim , replace the sixth number in the selected reference with 4.
 Some 110/120V \sim and 220/240V \sim references may not be available.

References of complete switches with 3 cable entries tapped for 1/2" NPT conduit

To order a switch with 3 1/2" NPT cable entries, replace the last number in the reference with 3.
 Example: XCSLF3737412 becomes **XCSLF3737413**. Some 1/2" NPT references may not be available.

References of actuating keys and separate parts

- See page 64.
- (1) Head adjustable in 90° steps through 360°. Blanking plug for operating head slot included with switch.
 - (2) A key-operated lock (2 keys included with switch) enables forced opening of the interlocking mechanism by authorized personnel, allowing withdrawal of the actuating key and subsequent opening of the NC safety contacts (auxiliary release).
 - (3) Trigger action, diameter 40 mm, "turn to release" or "key no. 455" reset type.
 - (4) Actuating keys to be ordered separately (see page 64).
 - (5) Common power supply for the solenoid and the LEDs.

Other versions: consult your Customer Care Center.

Safety detection solutions

Safety interlock switches



Key-operated with solenoid, turret head (1)
XCSLF metal, emergency release pushbutton,
connector output

Type of switch	Locking on de-energization and unlocking on energization of solenoid (2) with emergency release by mushroom head pushbutton (3)
----------------	--



LED indication	Orange LED: "guard open" indication Green LED: "guard closed and locked" indication
----------------	--

Power supply for the solenoid and the LEDs	24 V $\overline{\text{---}}$ or \sim (50/60 Hz on \sim)
--	--



Type of auxiliary contact actuated by the solenoid (locking contacts). Contact states represented with actuating key inserted and solenoid not energized.	1 NC + 2 NO break before make 	2 NC + 1 NO break before make 
--	--	--

References of switches without actuating key (4) (⊖ NC contact with positive opening operation)

Types of main contact actuated by the key

Contact states represented with actuating key inserted with trigger action mushroom head pushbutton, diameter 40 mm, "turn to release" reset

With 19-pin (6 contacts) M23 connector output

3-pole contact 1 NC + 2 NO break before make, slow break 	XCSLF353541M3 ⊖	–
3-pole contact 2 NC + 1 NO break before make, slow break 	–	XCSLF373741M3 ⊖
Weight (kg)	1.220	1.220

Solenoid and LED characteristics

Load factor	100%
Rated operational voltage (5)	24 V $\overline{\text{---}}$ or \sim
Voltage limits	Conforming to EN/IEC 60947-1 - 15%, + 10% of the rated operational voltage (including ripple on $\overline{\text{---}}$)
Consumption	< 5.4 W at 20 °C and max. voltage

References of actuating keys and separate parts

See page 64.

(1) Head adjustable in 90° steps through 360°. Blanking plug for operating head slot included with switch.

(2) A key-operated lock (two keys included with switch) enables forced opening of the interlocking mechanism by authorized personnel, allowing withdrawal of the actuating key and subsequent opening of the NC safety contacts (auxiliary release).

(3) Trigger action, diameter 40 mm, "turn to release".

(4) Actuating keys to be ordered separately (see page 64).

(5) Common power supply for the solenoid and the LEDs.

Note : Due to existing cable connections and to increase your personal safety, safety screws have been used on the front of the product to help prevent unauthorized access.

Other versions: consult your Customer Care Center.

Safety detection solutions

Safety interlock switches

Key-operated with solenoid, turret head (1)

XCSLE plastic, double insulated, 3 cable entries

Type of switch Locking on de-energization and unlocking on energization of solenoid (2)



LED indication	Orange LED: "guard open" indication Green LED: "guard closed and locked" indication				
Power supply for the solenoid and the LEDs	24 V $\overline{\text{---}}$ or \sim (50/60 Hz on \sim)				
Type of auxiliary contact actuated by the solenoid (locking contacts). Contact states represented with actuating key inserted and solenoid not energized.	1 NO + 1 NC break before make 	2 NC simultaneous 	1 NC + 2 NO break before make 	2 NC + 1 NO break before make 	3 NC simultaneous

References of switches without actuating key (3) (⊖ NC contact with positive opening operation)
Types of main contact actuated by the key
Contact states represented with actuating key inserted
With 3 cable entries tapped ISO M20 x 1.5

2-pole contact 1 NC + 1 NO break before make, slow break 	XCSLE2525312 ⊖	-	-	-	-
2-pole contact 2 NC simultaneous, slow break 	-	XCSLE2727312 ⊖	-	-	-
3-pole contact 1 NC + 2 NO break before make, slow break 	-	-	XCSLE3535312 ⊖	-	-
3-pole contact 2 NC + 1 NO break before make, slow break 	-	-	-	XCSLE3737312 ⊖	-
3-pole contact 3 NC simultaneous, slow break 	-	-	-	-	XCSLE3838312 ⊖
Weight (kg)	0.530	0.530	0.530	0.530	0.530

Solenoid and LED characteristics	
Load factor	100%
Rated operational voltage (4)	24 V $\overline{\text{---}}$ or \sim or 120 V \sim or 230 V \sim
Voltage limits	Conforming to EN/IEC 60947-1 - 15%, + 10% of the rated operational voltage (including ripple on $\overline{\text{---}}$)
Consumption	< 5.4 W at 20 °C and max. voltage

References of complete switches with solenoid supply voltage of 120 V or 230 V

To order a switch with a solenoid voltage of 110/120 V \sim , replace the sixth number in the selected reference with 3.
 Example: XCSLE2525312 becomes XCSLE2525332. Some 110/120 V \sim references may not be available.
 To order a switch with a solenoid voltage of 220/240 V \sim , replace the sixth number in the selected reference with 4.
 Example: XCSLE2525312 becomes XCSLE2525342. Some 220/240 V \sim references may not be available.

References of switches with locking on energization and unlocking on de-energization

To order a safety interlock switch with locking on energization and unlocking on de-energization of the solenoid, replace the fifth number in the selected reference with 5.
 Example: XCSLE2525312 becomes XCSLE2525512. Some references with locking on energization may not be available.

References of complete switches with three cable entries tapped for 1/2" NPT conduit

To order a switch with 1/2" NPT cable entries, replace the last number in the reference with 3.
 Example: XCSLE2727312 becomes XCSLE2727313. Some 1/2" NPT references may not be available.

References of actuating keys and separate parts

See page 64.

- (1) Head adjustable in 90° steps through 360°. Blanking plug for operating head slot included with switch.
- (2) A special tool included with the safety interlock switch enables forced opening of the interlocking mechanism by authorized personnel, allowing withdrawal of the actuating key and subsequent opening of the NC safety contacts (auxiliary release).
- (3) Actuating keys to be ordered separately (see page 64).
- (4) Common power supply for the solenoid and the LEDs.

Other versions: consult your Customer Care Center.

Presentation: page 54	Characteristics: page 55	Dimensions: page 65	Schemes: page 68
--------------------------	-----------------------------	------------------------	---------------------

Safety detection solutions

Safety interlock switches

Key-operated with solenoid, turret head (1)

XCSLE plastic, double insulated, connector output

Type of switch Locking on de-energization and unlocking on energization of solenoid (2)



LED indication Orange LED: "guard open" indication
Green LED: "guard closed and locked" indication

Power supply for the solenoid and the LEDs 24 V $\overline{\text{---}}$ or \sim (50/60 Hz on \sim)

Type of auxiliary contact actuated by the solenoid (locking contacts). Contact states represented with actuating key inserted and solenoid not energized.	1 NC + 2 NO break before make	2 NC + 1 NO break before make

References of switches without actuating key (3) (⊖ NC contact with positive opening operation)

Types of main contact actuated by the key

Contact states represented with actuating key inserted

With 16-pin (4 contacts) or 19-pin (6 contacts) M23 connector output

3-pole contact 1 NC + 2 NO break before make, slow break		XCSLE353531M3 ⊖	-
3-pole contact 2 NC + 1 NO break before make, slow break		-	XCSLE373731M3 ⊖
Weight (kg)		0.530	0.530

Solenoid and LED characteristics

Load factor	100%
Rated operational voltage (4)	24 V $\overline{\text{---}}$ or \sim
Voltage limits	Conforming to EN/IEC 60947-1 - 15%, + 10% of the rated operational voltage (including ripple on $\overline{\text{---}}$)
Consumption	< 5.4 W at 20 °C and max. voltage

References of actuating keys and separate parts

See page 64.

(1) Head adjustable in 90° steps through 360°. Blanking plug for operating head slot included with switch.

(2) A special tool included with the safety interlock switch enables forced opening of the interlocking mechanism by authorized personnel, allowing withdrawal of the actuating key and subsequent opening of the NC safety contacts (auxiliary release).

(3) Actuating keys to be ordered separately (see page 64).

(4) Common power supply for the solenoid and the LEDs.

Note : Due to existing cable connections and to increase your personal safety, safety screws have been used on the front of the product to help prevent unauthorized access.

Other versions: consult your Customer Care Center.

Safety detection solutions





Safety interlock switches

Key-operated with solenoid, turret head

XCSLF metal and XCSLE plastic

Accessories

References of actuating keys

				
Description	Straight actuating key	Actuating key with wide fixing	Pivoting actuating key	Latch for sliding doors
For XCSLF and XCSLE key-operated switches	XCSZ01	XCSZ02	XCSZ03	XCSZ05
Weight (kg)	0.020	0.020	0.095	0.600

Separate parts

PF090313



XCSZ90

Description	Used for	Unit reference	Weight kg
Blanking plugs for operating head slot (Sold in lots of 10)	XCSLF, XCSLE	XCSZ30	0.050
Keys for forced opening of interlocking device (Sold in lots of 10)	XCSLF	XCSZ25	0.100
Padlocking device to help prevent insertion of actuating key, for up to 3 padlocks (padlocks not included)	XCSLF, XCSLE	XCSZ90	0.055
Tool for forced opening of interlocking device (Sold in lots of 10)	XCSLE	XCSZ100	0.050
Cover safety kit consisting of: ■ 4 x 5-lobe torque screws ■ 1 magnetic screwdriver bit	XCSLF	XCSZ210	0.020
	XCSLE	XCSZ211	0.020

Characteristics

M23 connectors

Type of connection	Screw thread (metal clamping ring)
Degree of protection	IP 65 (with clamping ring correctly tightened)
Ambient air temperature	-25...+110 °C
Connection	To solder terminals. Maximum conductor c.s.a.: 1 mm ² Cable gland: no. 13 metal (Pg 13.5) Clamping capacity: 9 to 12 mm
LED signaling	–
Nominal voltage	60 V ~, 75 V ☐
Nominal current	7.5 A
Insulation resistance	> 10 ¹² Ω
Contact resistance	≤ 5 mΩ

Safety detection solutions

Safety interlock switches
Key-operated with solenoid, turret head
XCSLF metal and XCSLE plastic
Cabling accessories

References

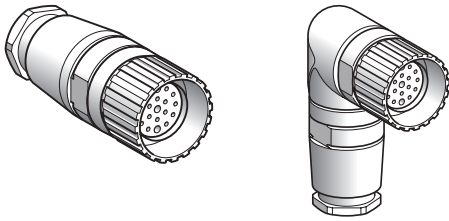

Type of connector	Number of contacts	Cable connection	Type	Reference	Weight kg
Female, M23	19	To solder terminals	Straight	XZCC23FDM190S	0.080
			Elbowed	XZCC23FCM190S	0.150

Dimensions

XZCC23FDM190S

XZCC23FCM190S

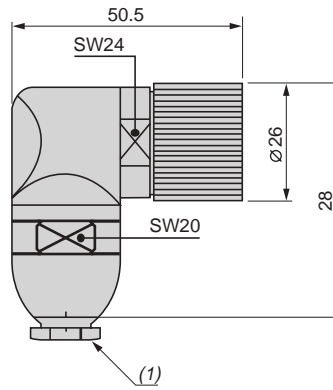
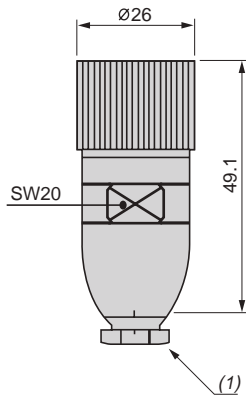

(1) No. 13 metal cable gland

Connections

XZCC23F•M190S

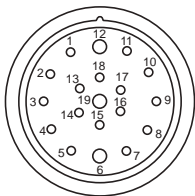

Safety detection solutions

Safety interlock switches

Key-operated with solenoid, turret head

XCSLF metal

XCSLE plastic

Dimensions

Metal safety interlock switches

XCSLF●●●●●●

XCSLF●●●●●●, with emergency release mushroom head pushbutton

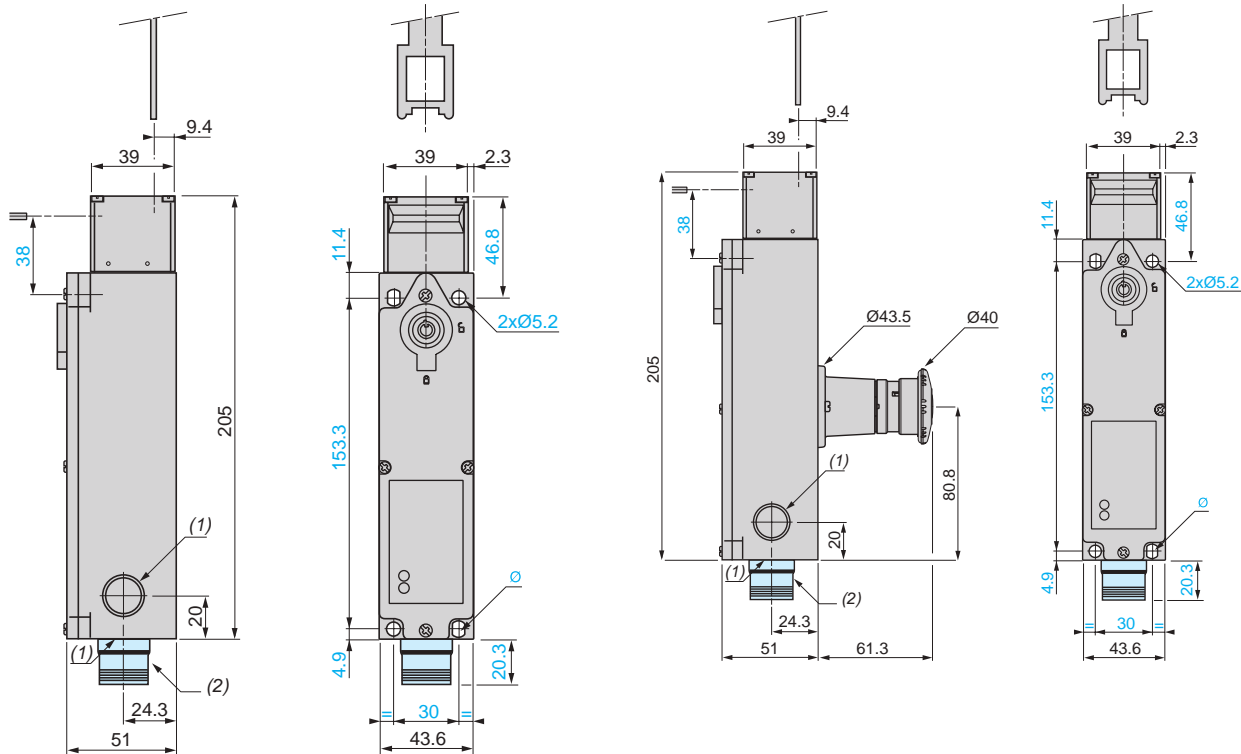

\varnothing : 2 elongated holes $\varnothing 7 \times 5.2$

\varnothing : 2 elongated holes $\varnothing 7 \times 5.2$

Plastic safety interlock switches

XCSLE●●●●●●

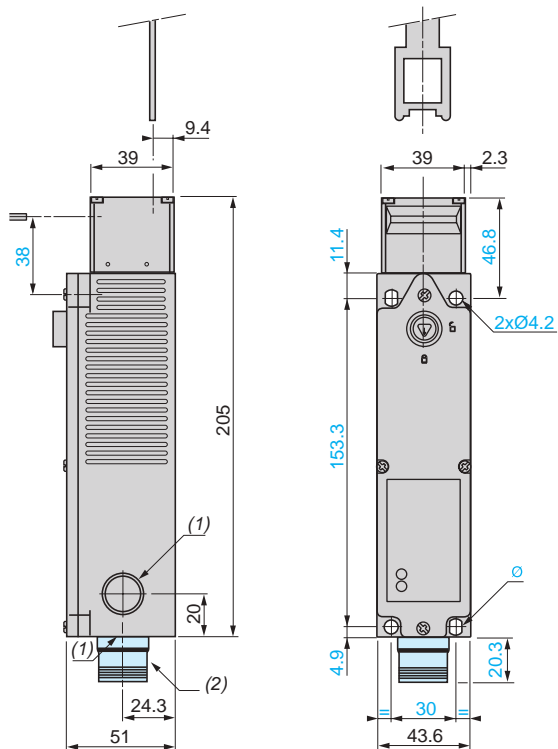

\varnothing : 2 elongated holes $\varnothing 6.2 \times 4.2$

(1) 3 tapped entries for cable gland.

(2) Version with M23 connector.

Dimensions (continued)

XCSZ01

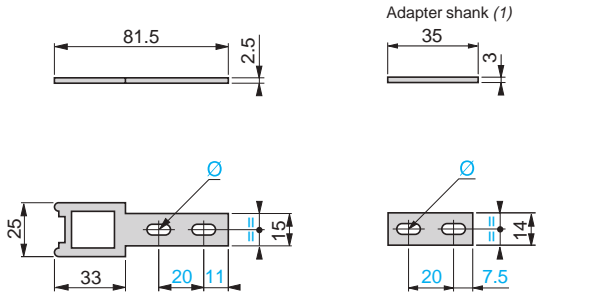

(1) Adapter (included with XCSZ01 actuating key) for replacing, without drilling an additional fixing hole, XCKJ or XCSL5/7 safety interlock switches with ZCKY07 actuating key by an XCSLF/LE safety interlock switch with XCSZ01 actuating key.

Ø: 2 elongated holes Ø 5.3 x 10

XCSZ02

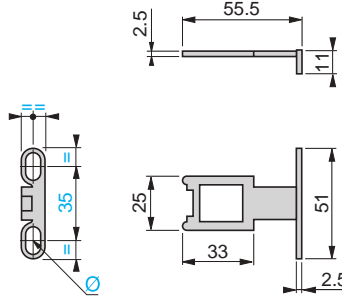

Ø: 2 elongated holes Ø 5.3 x 10

XCSZ03

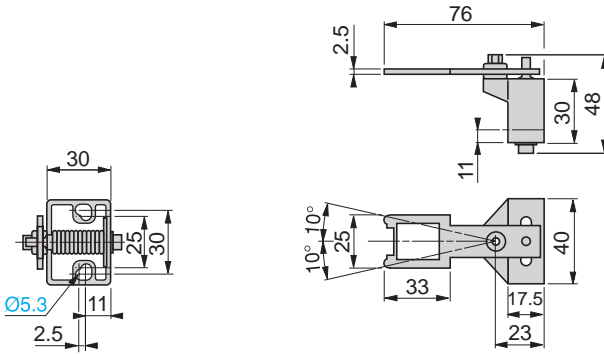

Fixing axis % related to actuating key.

XCSZ05

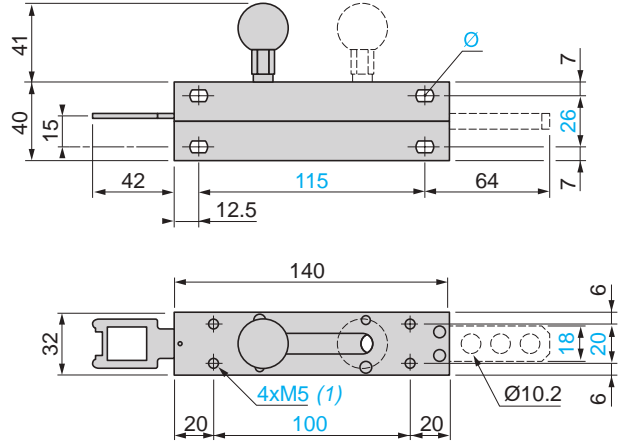

(1) Depth: 10
Ø: 4 elongated holes Ø 5.2 x 8

Actuation radius

XCSZ01

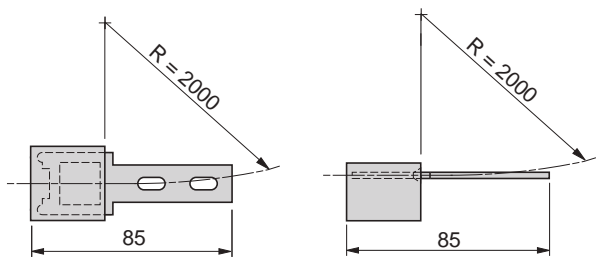

XCSZ02

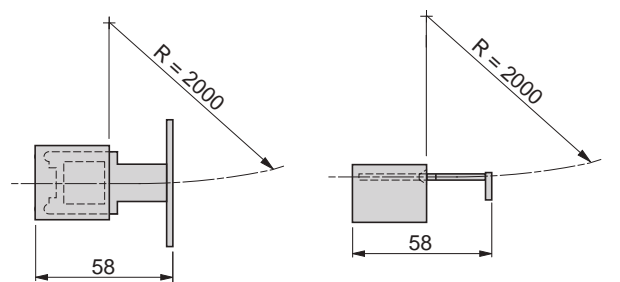

XCSZ03

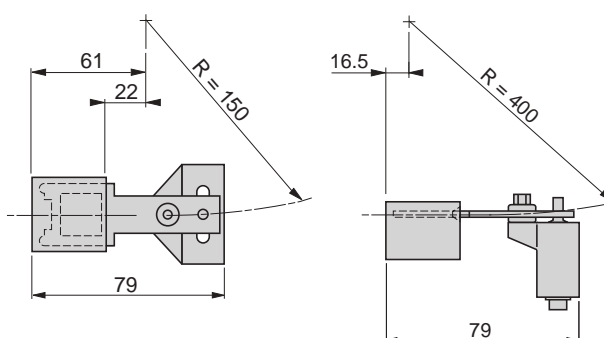

R = minimum radius

Safety detection solutions

Safety interlock switches

Key-operated with solenoid, turret head

XCSLF metal

XCSLE plastic

Operation

Functional diagrams

XCSLF25●●●
XCSLE25●●●

XCSLF27●●●
XCSLE27●●●

XCSLF35●●●
XCSLE35●●●

XCSLF37●●●
XCSLE37●●●

XCSLF38●●●
XCSLE38●●●

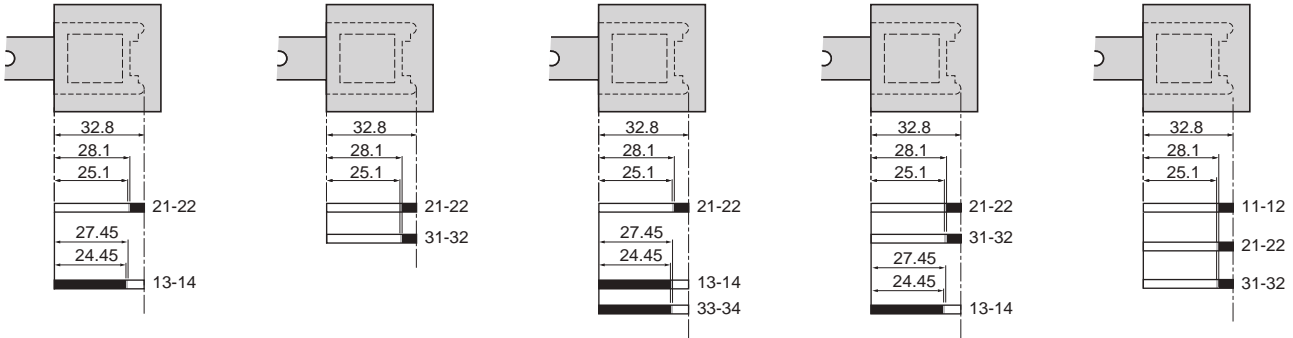

Contact operation

■ Closed □ Open ■ Transient state

Connection examples

The contact states are represented with the actuating key inserted and the solenoid not energized

Note: These schemes are given as examples only, the designer should refer to the relevant safety standards for guidance.

Wiring up to PL=b, category 1 conforming to EN/ISO 13849-1

Wiring example with protection fuse to help prevent shunting of the NC contact, due to either cable damage or tampering

1 NC + 1 NO locking on de-energization and 1 NC + 1 NO auxiliary contacts

XCSLF25253●● and XCSLE25253●●

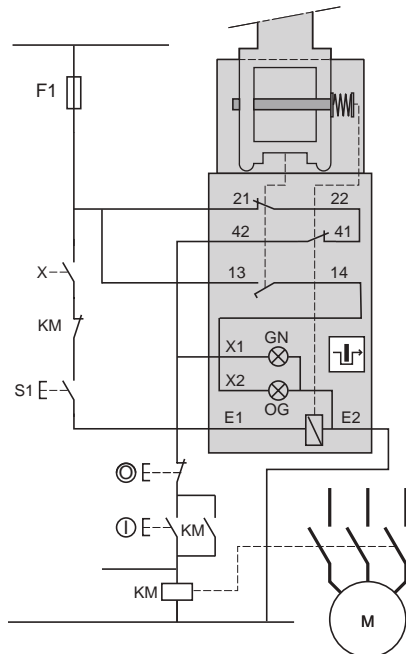

E1-E2: Solenoid supply
21-22: Safety contact, key position monitoring
13-14: Safety contact, key position signaling
41-42: Solenoid position monitoring contact
13-X2/E2: LED (orange): key withdrawn
41-X1/E2: LED (green): key inserted and locked
22-41 : Safety pre-wiring mandatory
S1: Manual release button
X: Unlocking signal

Wiring up to PL=d, category 3 conforming to EN/ISO 13849-1

Wiring example with redundancy for the safety interlock switch contacts, without monitoring or redundancy in the power circuit.

2 NC + 1 NO locking on de-energization and 2 NC + 1 NO auxiliary contacts

XCSLF37373●● and XCSLE37373●●

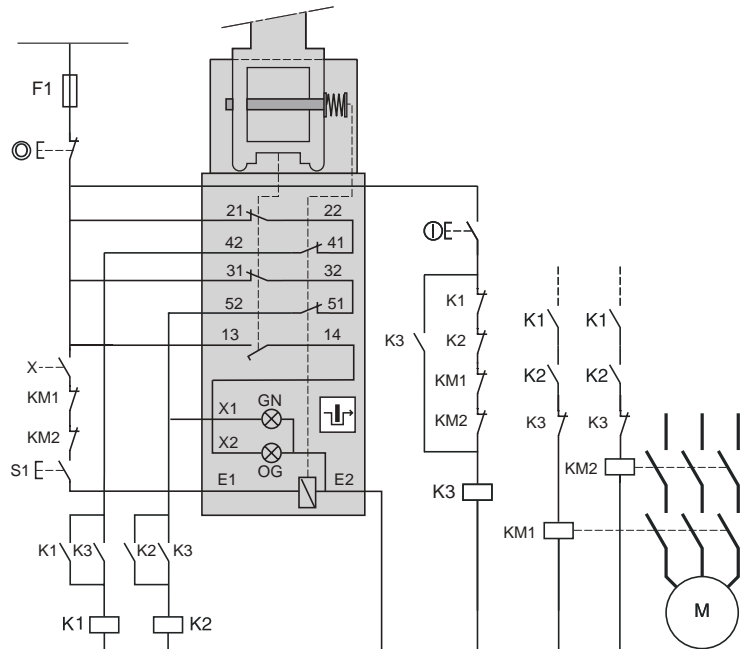

E1-E2: Solenoid supply
21-22 and 31-32: Redundant safety contacts, key position monitoring
41-42 and 51-52: Redundant contacts, solenoid position monitoring
13-14: Safety contact, key position signaling
13-X2/E2: LED (orange): key withdrawn
51-X1/E2: LED (green): key inserted and locked
22-41 and 32-51: Safety pre-wiring mandatory
S1: Manual release button
X: Zero speed or unlocking signal

Safety detection solutions

Safety interlock switches

Key-operated with solenoid, turret head

XCSLF metal

XCSLE plastic

Connection examples (continued)

The contact states are represented with the actuating key inserted and the solenoid not energized.

Wiring up to PL=e, category-4 conforming to EN/ISO 13849-1 and EN/IEC 62061 (assuming that failure of the single mechanical point can be excluded)

Wiring example with 2-LED module associated with an XPSUA● (1) safety control unit

Wiring to PL=e, category 4 conforming to EN/ISO 13849-1 and SIL CL3 conforming to EN/IEC 62061. Wiring method used in conjunction with an XPS safety control unit (the safety interlock switch should be used in conjunction with a safety limit switch to achieve electrical/mechanical redundancy).

Method for machines with long rundown time (high inertia)

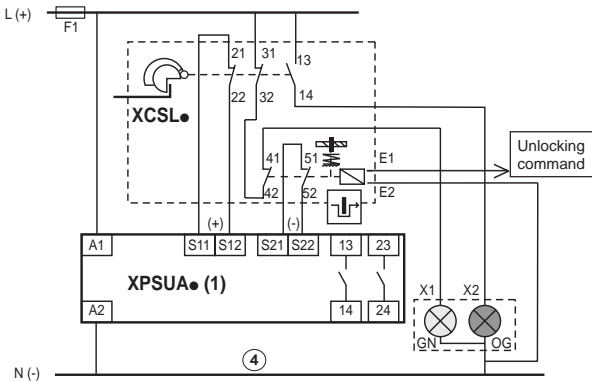

(1) XPSUAF● / XPSUAK● / XPSUAT●

- E1-E2: Solenoid supply
- 13-14: Safety contact, key position signaling
- 13-X2/E2: LED (orange): key not inserted
- 41-X1/E2: LED (green): key inserted and locked
- 21-22 and 31-32: Redundant safety contacts, key position monitoring
- 41-42 and 51-52: Redundant contacts, solenoid position monitoring

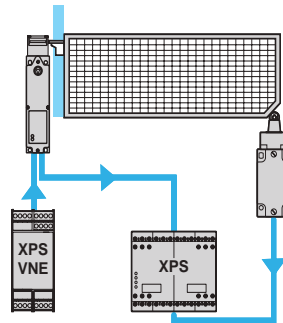

Interlocking device for actuating key fitted on guard and zero speed detection.

19-pin M23 connectors

XCSLF3535●● and XCSLE3535●●

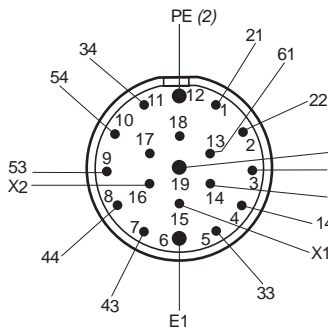

XCSLF3737●● and XCSLE3737●●

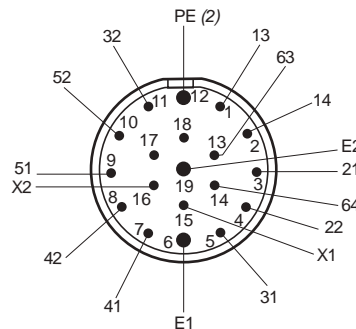

XCSLF3837●● and XCSLE3837●●

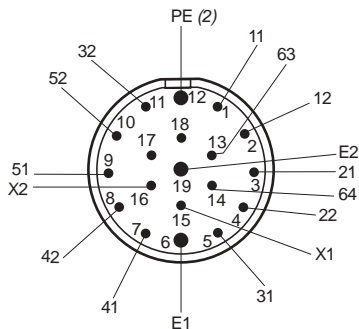

XCSLF3838●● and XCSLE3838●●

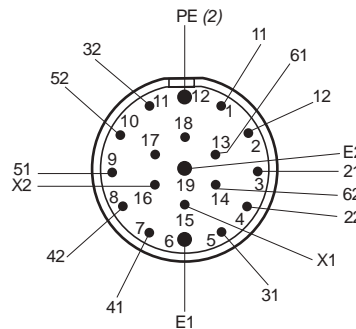

(2) PE (Protective Earth) connection

Safety detection solutions

Safety interlock switches

Key-operated with solenoid, turret head

XCSE and XCSTE rectangular design

XCSE metal

Safety interlock switches operated by actuating key



Page 72

XCSTE plastic

Safety interlock switches operated by actuating key



Page 78

Environmental characteristics

Safety interlock switch type		XCSE (metal)	XCSTE (plastic)
Conformity to standards	Products	EN/IEC 60947-5-1, UL 508, CSA C22-2 no. 14	EN/IEC 62061, EN/IEC 60947-1
	Machine assemblies	EN/IEC 60204-1, EN/ISO 14119	
Product certifications		UL, CSA, CCC, EAC	UL, CSA, CCC, EAC
Maximum safety level (1)		PL=e, category 4 conforming to EN/ISO 13849-1 and SIL 3 conforming to EN/IEC 61508	
Reliability data B _{10D}		5,000,000 (data value for a service life of 20 years can be limited by contact and mechanical wear)	
Ambient air temperature	For operation	-25...+40 °C	-25...+60 °C
	For storage	-40...+70 °C	
Vibration resistance		5 gn (10...500 Hz) conforming to EN/IEC 60068-2-6	
Shock resistance		10 gn (duration 11 ms) conforming to EN/IEC 60068-2-27	
Electric shock protection		Class I conforming to EN/IEC 61140	Class II conforming to EN/IEC 61140
Degree of protection		IP 67 conforming to EN/IEC 60529 and EN/IEC 60947-5-1 (2)	
Cable entry		2 entries tapped ISO M20 x 1.5 (clamping capacity 7 to 13 mm) or tapped for Pg 13.5 cable gland (clamping capacity 8 to 12 mm) or for 1/2" NPT conduit	1 entry tapped M16 x 1.5 (clamping capacity 4.5 to 10 mm) or tapped for Pg 11 cable gland (clamping capacity 7 to 10 mm) or for 1/2" NPT conduit using metal adapter DE9RA1012 with Pg 11 tapped entry
Connecting cable		–	4 x 0.5 mm ²
Materials		Zamak case	Polyamide PA66 fibreglass impregnated case
		Actuating keys (all types): steel XC60, surface treated	

(1) Using an appropriate and correctly connected safety control unit.

(2) Live parts of these switches are protected to some extent against the penetration of dust and water. However, when installing take all necessary precautions to help prevent the penetration of solid bodies, or liquids with a high dust content, into the actuating key aperture. Use of XCSZ27 (with XCSE) or XCSZ28 (with XCSTE) blanking plugs for unused key slots can reduce the penetration of unwanted elements (one blanking plug is delivered with the product). Not recommended for use in saline atmospheres.

Contact block characteristics		
Rated operational characteristics	2 and 3 contacts, slow break	XCSE, XCSTE: ~ AC-15, B300: $U_e = 240\text{ V}$, $I_e = 1.5\text{ A}$ or $U_e = 120\text{ V}$, $I_e = 3\text{ A}$ All models: --- DC-13, Q300: $U_e = 250\text{ V}$, $I_e = 0.27\text{ A}$ or $U_e = 125\text{ V}$, $I_e = 0.55\text{ A}$ conforming to EN/IEC 60947-5-1
Conventional thermal current in enclosure		XCSE, XCSTE 2 and 3 slow break contact versions: $I_{the} = 6\text{ A}$
Rated insulation voltage	2 and 3 contacts	3 contacts (XCSE), 2 contacts (XCSTE): $U_i = 500\text{ V}$ conforming to EN/IEC 60947-1; $U_i = 300\text{ V}$ conforming to UL 508, CSA C22-2 no. 14
Rated impulse withstand voltage	2 and 3 contacts	3 contacts (XCSE), 2 contacts (XCSTE): $U_{imp} = 6\text{ kV}$ conforming to EN/IEC 60947-5-1
Positive operation		NC contacts with positive opening operation conforming to EN/IEC 60947-5-1, Section 3
Resistance across terminals		$\leq 30\text{ m}\Omega$ conforming to EN/IEC 60947-5-4
Short-circuit protection	2 and 3 contacts	3 contacts (XCSE), 2 contacts (XCSTE): 10 A cartridge fuse type gG (gl)
Connection	Screw clamp terminals	2 and 3 contacts 3 contacts (XCSE), 2 contacts (XCSTE): Clamping capacity, min: $1 \times 0.5\text{ mm}^2$, max: $2 \times 1.5\text{ mm}^2$ with or without cable end

Complementary characteristics

Actuation speed	Maximum: 0.5 m/s, minimum: 0.01 m/s
Resistance to forcible withdrawal of actuating key (locked)	XCSE: $F_{1max} = 2600\text{ N}$; $F_{Zh} = 2000\text{ N}$; XCSTE: $F_{1max} = 650\text{ N}$; $F_{Zh} = 500\text{ N}$
Mechanical durability	XCSE: > 1 million operating cycles XCSTE: 1 million operating cycles
Maximum operating rate	For maximum durability: 600 operating cycles per hour
Minimum force for extraction of actuating key (not locked)	$\geq 20\text{ N}$
Materials	Body and head: Zamak (XCSE) Body and head: polyamide PA66, fibreglass impregnated (XCSTE)

Electrical durability

- Conforming to EN/IEC 60947-5-1 Appendix C
- Utilization categories AC-15 and DC-13
- Maximum operating rate: 3600 operating cycles/hour
- Load factor: 0.5

XCSE 3-contact and XCSTE 2-contact version, slow break

AC supply
50/60 Hz ~
r.m. inductive circuit

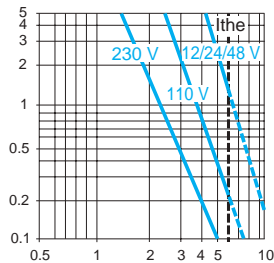

DC supply ---
Power broken in W for
5 million operating cycles.

Voltage	V	24	48	120
r.m.	W	13	9	7

Safety detection solutions

Safety interlock switches

Key-operated with solenoid, turret head (1)

XCSE metal, 2 cable entries

Type of switch

Locking on de-energization and unlocking on energization of solenoid (2)



LED indication

Orange LED: "guard open" signaling (not available on 3NC main contact models).
Green LED: "guard closed and locked" signaling.

Solenoid supply voltage

24 V $\overline{\text{---}}$ or \sim (50/60 Hz on \sim)	48 V $\overline{\text{---}}$ or \sim (50/60 Hz on \sim)	110/120 V $\overline{\text{---}}$ or \sim (3) (50/60 Hz on \sim)	220/240 V $\overline{\text{---}}$ or \sim (3) (50/60 Hz on \sim)
---	---	--	--

Types of auxiliary contacts actuated by the solenoid (locking contacts). Contact states represented with actuating key inserted and solenoid not energized.

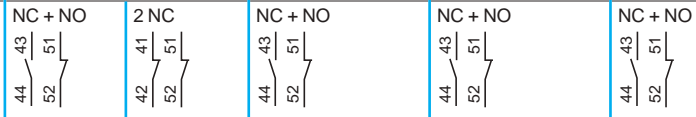

References of switches without actuating key (5) (⊖ NC contact with positive opening operation)

Types of main contacts actuated by the key
Contact states represented with actuating key inserted
With 2 cable entries tapped ISO M20 x 1.5

3-pole NC + NO + NO (2 NO break before make) slow break 	XCSE5312 ⊖	-	XCSE5322 ⊖	XCSE5332 ⊖	XCSE5342 ⊖
3-pole NC + NC + NO (NO break before make) slow break 	XCSE7312 ⊖	XCSE73127 ⊖	-	XCSE7332 ⊖	XCSE7342 ⊖
3-pole NC + NC + NC slow break 	XCSE8312 ⊖ (4)	XCSE83127 ⊖ (4)	-	-	-
Weight (kg)	1.140	1.140	1.140	1.140	1.140

References of switches with locking on energization and unlocking on de-energization

To order a safety interlock switch with locking on energization and unlocking on de-energization of the solenoid, replace the second number (3) with 5 in the references shown above. Example: XCSE5312 becomes **XCSE5512**. For these models, the auxiliary contacts states are also represented with key inserted and solenoid not energized. 2 NC auxiliary contact models cannot be ordered with locking on energization. Some references with locking on energization may not be available.

References of switches with locking on de-energization and unlocking on energization with emergency release by mushroom head pushbutton

To order a switch with locking on de-energization and with emergency release pushbutton replace the second number (3) with 4 in the references shown above. Example: XCSE7312 becomes **XCSE7412**. Some references with trigger action mushroom head pushbutton may not be available.

References of switches with 2 cable entries tapped Pg 13.5 or 1/2" NPT

To order a switch with 2 cable entries for Pg 13.5 cable gland:

- replace the last number (2) with 1 in the selected reference. Example: XCSE5312 becomes **XCSE5311**.
- for switches with 7 at the end of the reference, replace the 2 before the 7 with 1 in the selected reference. Example: XCSE73127 becomes **XCSE73117**.

To order a switch with 2 cable entries for 1/2" NPT conduit:

- replace the last number (2) with 3 in the selected reference. Example: XCSE5312 becomes **XCSE5313**.
- for switches with 7 at the end of the reference, replace the 2 before the 7 with 3 in the selected reference. Example: XCSE73127 becomes **XCSE73137**.

Some Pg 13 and 1/2" NPT references may not be available.

References of actuating keys

See page 73

(1) Head adjustable in 90° steps through 360°. Blanking plug for operating head slot included with switch.

(2) A key-operated lock (2 keys included with switch) enables forced opening of the interlocking mechanism, by authorized personnel, allowing withdrawal of the actuating key and subsequent opening of the NC safety contacts (auxiliary release).

(3) For use on 110/120 V $\overline{\text{---}}$ or 220/240 V $\overline{\text{---}}$, remove the LED indicator module.

(4) Switches supplied with a single green LED.

(5) Actuating keys to be ordered separately (see page 73).

Other versions: please consult our Customer Care Center.

Safety detection solutions

Safety interlock switches
Key-operated with solenoid, turret head
XCSE metal, 2 cable entries

Solenoid characteristics					
Load factor	100%				
Rated operational voltage	~ or --- 24 V	~ or --- 24 V	~ or --- 48 V	~ or --- 110/120 V	~ or --- 220/240 V
Voltage limits	Conforming to EN/IEC 60947-1 - 15%, + 10% of the rated operational voltage (including ripple on ---)				
Service life	20,000 hours				
Consumption	Inrush: 10 VA. Sealed: 10 VA				

LED indicator characteristics		
Rated insulation voltage	50 V conforming to EN/IEC 60947-1	250 V conforming to EN/IEC 60947-1
Current consumption	7 mA	7 mA
Rated operational voltage	~ or 24/48 V ---	110/240 V ~
Voltage limits	~ or 20...52 V --- (including ripple)	95...264 V ~ (including ripple)
Service life	100,000 hours	100,000 hours
Protection against overvoltages	Yes	Yes

Separate components

PF000313



XCSZ90

Description	For use with	Key withdrawal positions from lock	Unit reference	Weight kg
Blanking plugs for operating head slot (Sold in lots of 10)	XCSE	–	XCSZ27	0.050
Keys for forced opening of interlocking device (Sold in lots of 10)	XCSE	–	XCSZ25	0.100

Padlocking device to help prevent insertion of actuating key, for up to 3 padlocks (padlocks not included)	XCSE	–	XCSZ90	0.055
--	------	---	--------	-------

PF59560_A



DE9RA2012

Description	For use with	Unit reference	Weight kg
1/2" NPT conduit female, M20 male adapter (Sold in lots of 5)	XCSE	DE9RA2012	0.048
M20 x 1.5 female, Pg 13.5 male adapter (Sold in lots of 5)	XCSE	DE9RP13520	0.032

References of actuating keys



Description	Straight actuating key	Actuating key with wide fixing	Pivoting actuating key	Latch for sliding doors
For XCSE key-operated switches	XCSZ01	XCSZ02	XCSZ03	XCSZ05
Weight (kg)	0.020	0.020	0.095	0.600

Dimensions

Safety interlock switches

XCSE●●●●

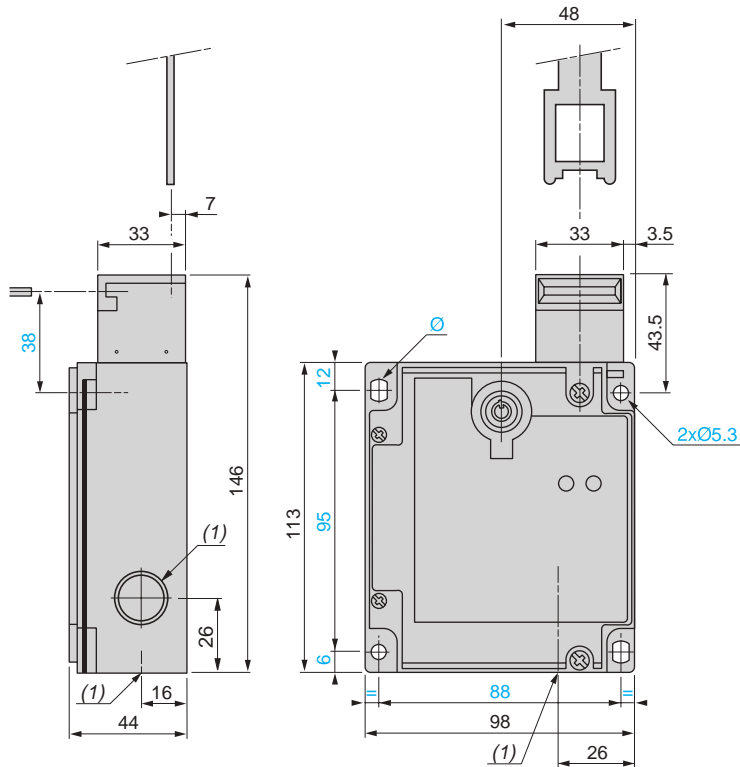

(1) 1 tapped entry for cable gland.

Ø: 2 elongated holes Ø 5.3 x 7.3

M20 x 1.5 adapter

DE9RP13520

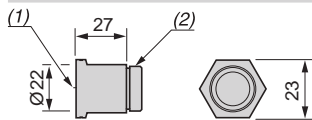

(1) M20 x 1.5 tapped entry

(2) Pg 13.5 threaded shank

1/2" NPT conduit adapter

DE9RA2012

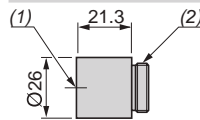

(1) Tapped entry for 1/2" NPT conduit

(2) M20 x 1.5 threaded shank

Actuating keys

XCSZ01

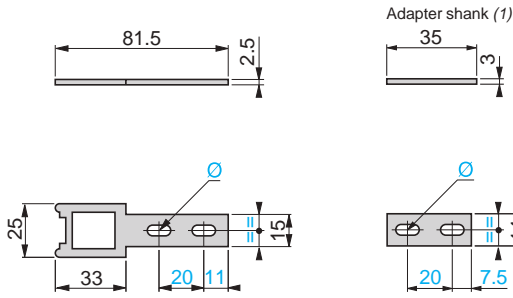

XCSZ02

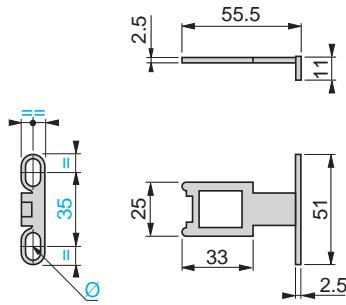

(1) Adapter (included with XCSZ01 actuating key) for replacing, without drilling an additional fixing hole, an XCKJ guard switch with ZCKY07 actuating key by an XCSEA, XCSB or XCSC guard switch with XCSZ01 actuating key.

Ø: 2 elongated holes Ø 5.3 x 10

Ø: 2 elongated holes Ø 5.3 x 10

XCSZ03

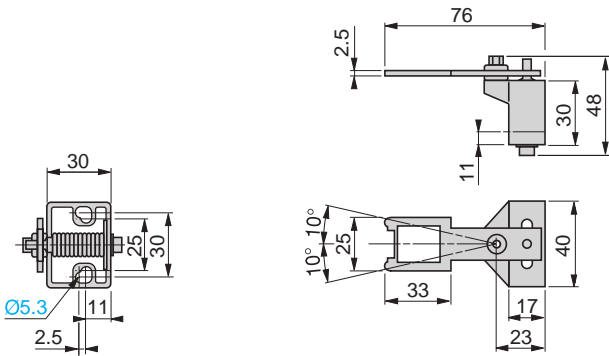

XCSZ05

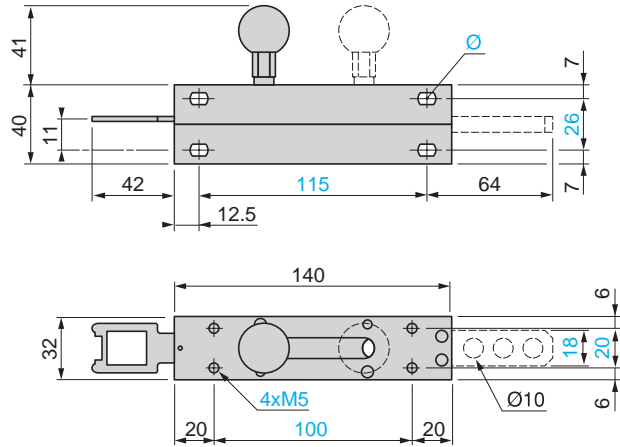

Fixing axis % related to actuating key.

Ø: 4 elongated holes Ø 5.3 x 7.3

Operating radius required for actuating key

XCSZ01

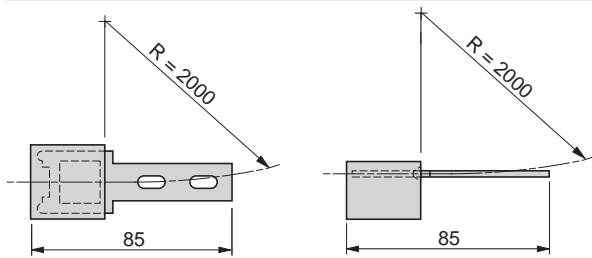

XCSZ02

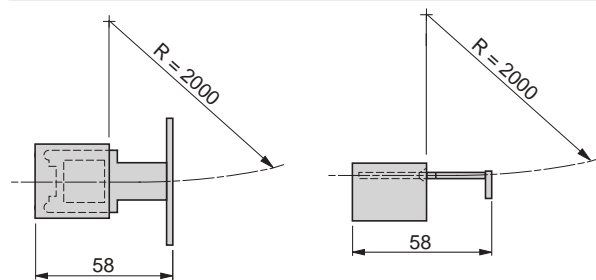

XCSZ03

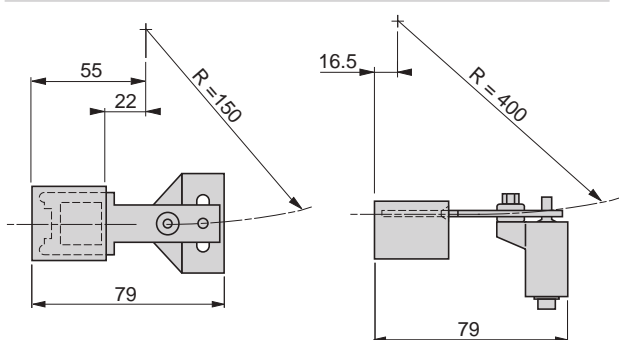

R = minimum radius

Safety detection solutions

Safety interlock switches
Key-operated with solenoid, turret head
XCSE metal, 2 cable entries

Setting-up

Functional diagrams

XCS•5•••

XCS•7•••

XCS•8•••

Contact operation

- Closed
- Open
- Transient state

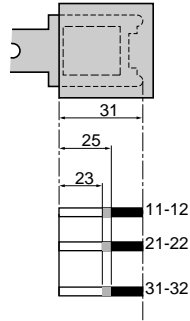
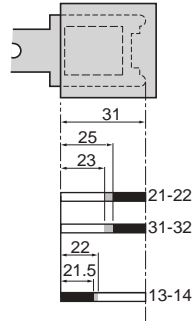
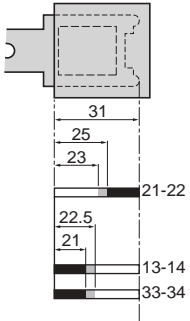

Schemes

Contact states are represented with the actuating key inserted and the solenoid not energized.

Note: These schemes are given as examples only, the designer should refer to the relevant safety standards for guidance.

Wiring to PL=b, category 1 conforming to EN/ISO 13849-1

Example with 3-pole NC + NO + NO contact and protection fuse to help prevent shunting of the NC contact, due to either cable damage or tampering.

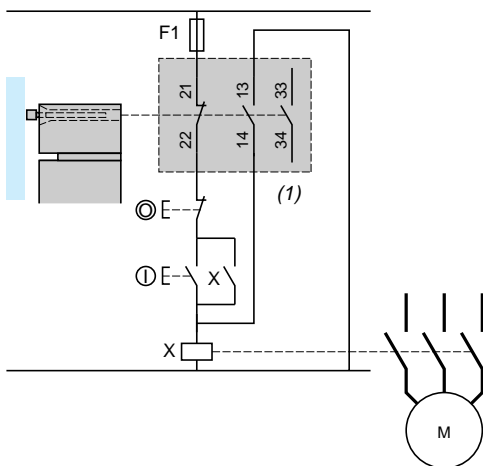

(1) Signaling contact

Wiring to PL=d, category 3 conforming to EN/ISO 13849-1

Example with 3-pole NC + NO + NO contact with mixed redundancy of the contacts and the associated control relays. To activate K1, it is necessary to remove and re-insert the actuating key when the supply is switched on.

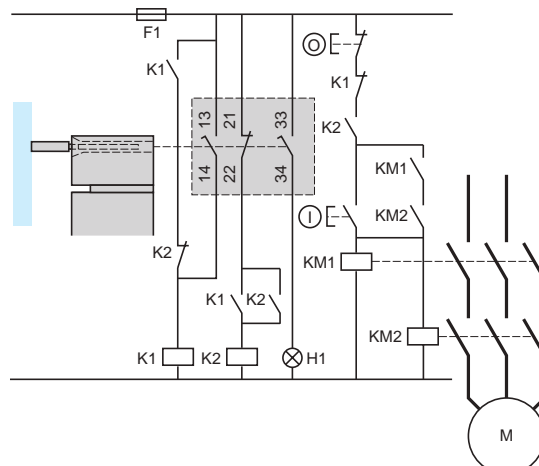

H1: "Actuating key not inserted" indicator

Schemes (continued)

Contact states are represented with the actuating key inserted and the solenoid not energized.

Note: These schemes are given as examples only, the designer should refer to the relevant safety standards for guidance.

Wiring to PL=b, category 1 conforming to EN/ISO 13849-1

Wiring examples with protection fuse to help prevent shunting of the NC contact, due to either cable damage or tampering.

Locking on de-energization, NC + NO + NO

Locking on energization, NC + NO + NO

XCSE53●●

XCSE55●●

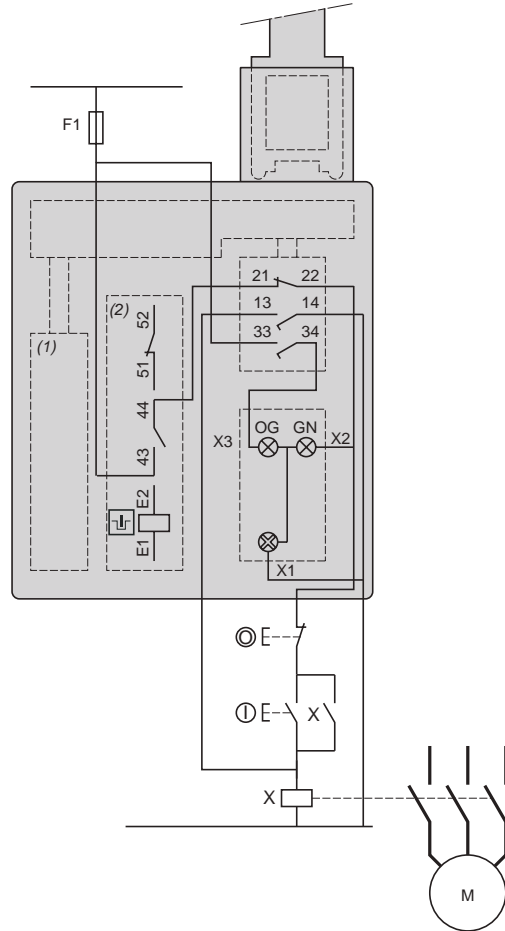
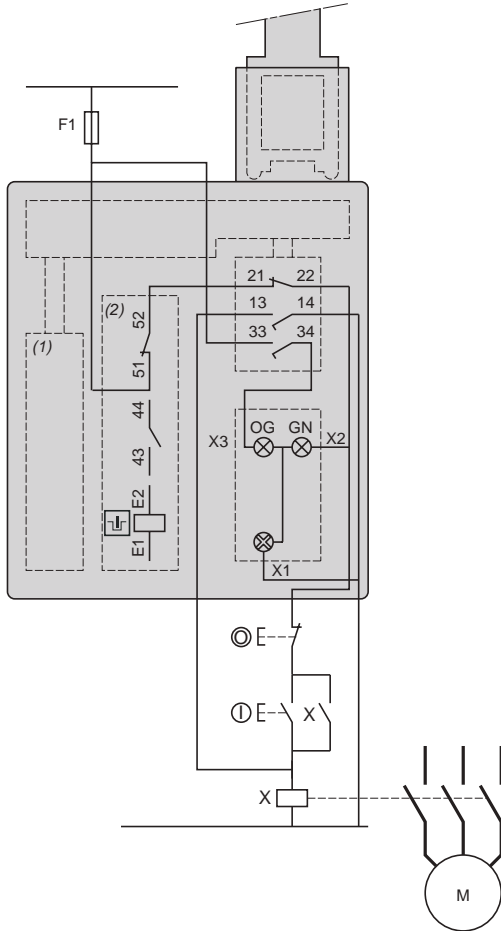

(1) Solenoid

(2) Auxiliary contact

E1-E2: Solenoid supply

43-44: Solenoid position signaling contact

51-52: Solenoid position monitoring contact

21-22: Safety contact: key position monitoring

33-34: Safety contact: key position signaling

13-14: Safety contact for detecting a possible shunt on 21-22 NC contact

33-X1: LED (orange): key withdrawn

51-X1: LED (green): key inserted and locked

21-52: Safety pre-wiring mandatory

(1) Solenoid

(2) Auxiliary contact

E1-E2: Solenoid supply

43-44: Solenoid position signaling contact

51-52: Solenoid position monitoring contact

21-22: Safety contact: key position monitoring

33-34: Safety contact: key position signaling

13-14: Safety contact for detecting a possible shunt on 21-22 NC contact

33-X1: LED (orange): key withdrawn

43-X1: LED (green): key inserted and locked

21-44: Safety pre-wiring mandatory

Safety detection solutions

Safety interlock switches

Key-operated with solenoid, turret head

XCSE metal, 2 cable entries

Schemes (continued)

Contact states are represented with the actuating key inserted and the solenoid not energized.

Note: These schemes are given as examples only, the designer should refer to the relevant safety standards for guidance.

Wiring to PL=d, category 3 conforming to EN/ISO 13849-1

Wiring examples with redundancy for the safety interlock switch contacts, without monitoring or redundancy in the power circuit

Locking on de-energization, NC + NC + NO

XCSE73●●

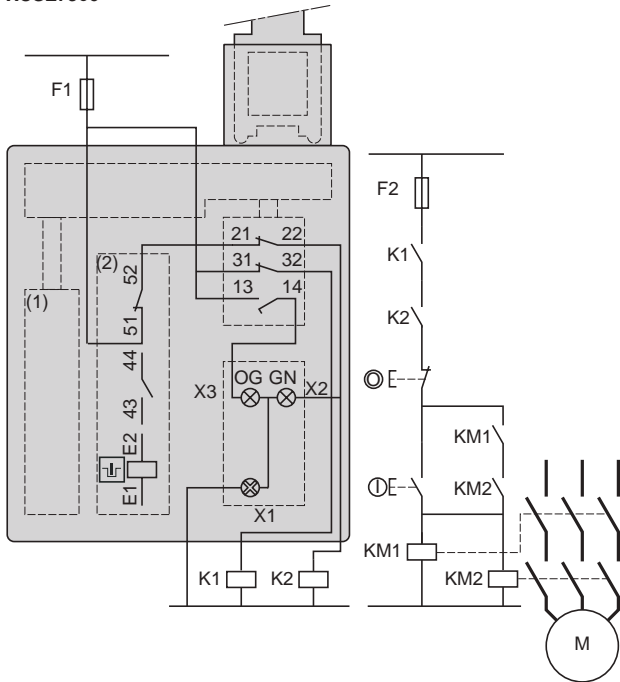

Locking on de-energization, NC + NC + NO

XCSE73●●7

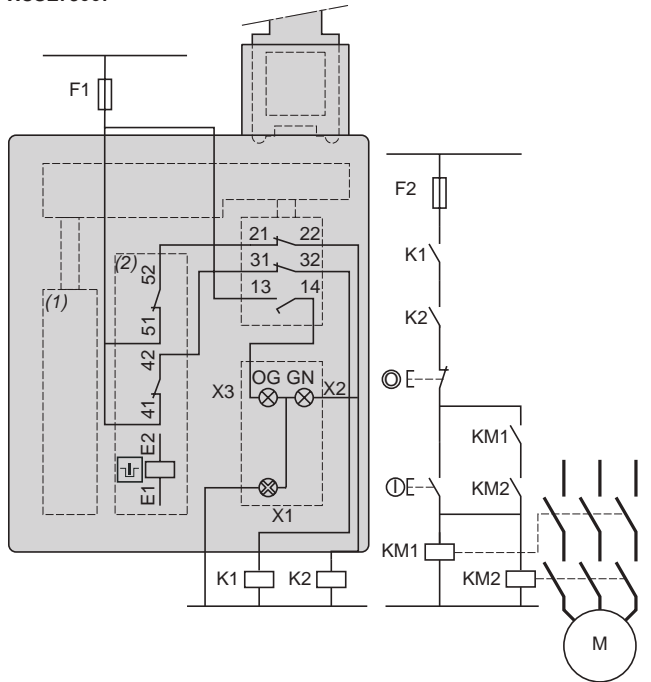

(1) Solenoid

(2) Auxiliary contact

E1-E2: Solenoid supply

21-22 and 31-32: Redundant safety contacts, key position monitoring

13-14: Safety contact, key position signaling

51-52: Solenoid position monitoring contact

43-44: Solenoid position signaling contact

13-X1: LED (orange): key withdrawn

51-X1: LED (green): key inserted and locked

21-52: Safety pre-wiring mandatory
page 72

(1) Solenoid

(2) Auxiliary contact

E1-E2: Solenoid supply

21-22 and 31-32: Redundant safety contacts, key position monitoring

13-14: Safety contact, key position signaling

41-42 and 51-52: Redundant contacts, Solenoid position monitoring

13-X1: LED (orange): key withdrawn

51-X1: LED (green): key inserted and locked

21-52 and 42-31: Safety pre-wiring mandatory

Dimensions:
page 73

Schemes (continued)

Contact states are represented with the actuating key inserted and the solenoid not energized.

Note: These schemes are given as examples only, the designer should refer to the relevant safety standards for guidance.

Wiring to PL=d, category 3 conforming to EN/ISO 13849-1

Wiring examples with redundancy for the safety interlock switch contacts, without monitoring or redundancy in the power circuit

Wiring to PL=e, category 4 conforming to EN/ISO 13849-1 and SIL 3 conforming to EN/IEC 61508. Wiring method used in conjunction with a control unit

(The safety interlock switch should be used in conjunction with a safety limit switch to give electrical/mechanical redundancy).

Locking on energization, NC + NC + NO

XCSE75●●

Method for machines with long rundown time (high inertia)

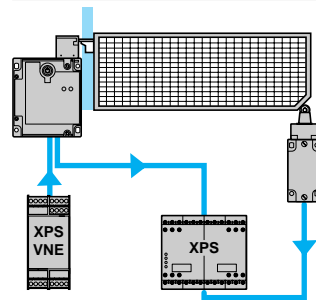
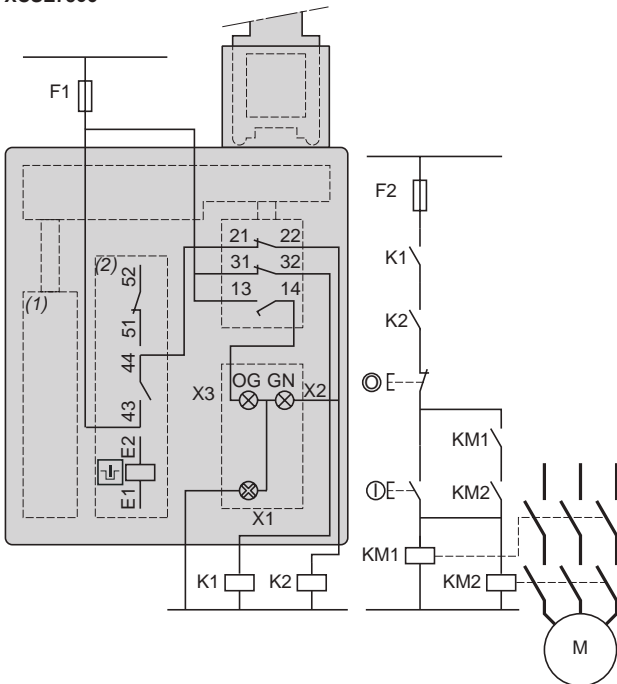

Interlocking device for actuating key fitted on guard and zero speed detection.

(1) Solenoid

(2) Auxiliary contact

E1-E2: Solenoid supply

21-22 and 31-32: Redundant safety contacts, key position monitoring

13-14: Safety contact, key position signaling

43-44: Solenoid position monitoring contact

51-52: Solenoid position signaling contact

13-X1: LED (orange): key withdrawn

43-X1: LED (green): key inserted and locked

21-44: Safety pre-wiring mandatory

Safety detection solutions

Safety interlock switches

Key-operated with solenoid, turret head (1)

XCSTE plastic, 1 cable entry

Type of switch

Locking on de-energization and unlocking on energization of solenoid (2)



Types of auxiliary contact actuated by the solenoid (locking contact). Contact state NC is to be considered with actuating key inserted and solenoid not energized.

24 V $\overline{\text{---}}$ or \sim (50/60 Hz on \sim)



120 V $\overline{\text{---}}$ or \sim (50/60 Hz on \sim)



230 V $\overline{\text{---}}$ or \sim (50/60 Hz on \sim)



References of switches without actuating key (3) (⊖ NC contact with positive opening operation) with 1 cable entry tapped ISO M16 x 1.5

2-pole NC + NC break before make, slow break		XCSTE5312 ⊖	XCSTE5332 ⊖	XCSTE5342 ⊖
2-pole NO + NC make before break, slow break		XCSTE6312 ⊖	—	—
2-pole NC + NC slow break		XCSTE7312 ⊖	—	XCSTE7342 ⊖
Weight (kg)		0.360	0.360	0.360

References of switches with locking on energization and unlocking on de-energization

To order a Safety interlock switch with locking on energization and unlocking on de-energization of the solenoid, replace the second number (3) with 5. Example: XCSTE5312 becomes **XCSTE5512**. For these models, the auxiliary contact state is to be considered with key inserted and solenoid not energized and the contact terminals are identified 33 - (34) $\overline{\text{---}}$ (34), Some references with locking on energization may not be available.

References of switches with 1 cable entry tapped Pg 11 or 1/2" NPT

To order a switch with 1 cable entry for Pg 11 cable gland, replace the last number (2) with 1 in the selected reference.

Example: XCSTE5312 becomes **XCSTE5311**.

To order a switch with 1 cable entry for 1/2" NPT conduit, replace the last number (2) with 3 in the selected reference.

Example: XCSTE5312 becomes **XCSTE5313**. The Pg 11 tapped entry is fitted with metal adapter DE9RA1012 for 1/2" NPT conduit.

Some Pg 13 and 1/2" NPT references may not be available.

Solenoid characteristics

Load factor	100%		
Rated operational voltage	24 V $\overline{\text{---}}$ or \sim (50/60 Hz on \sim)	120 V $\overline{\text{---}}$ or \sim (50/60 H on \sim)	230 V $\overline{\text{---}}$ or \sim (50/60 Hz on \sim)
Voltage limits	- 15%, +10% of the rated operational voltage (including ripple on $\overline{\text{---}}$) conforming to EN/IEC 60947-1		
Service life	20,000 hours		
Consumption	10 VA max.		

(1) Head adjustable in 90° steps through 360°. Blanking plug for operating head slot included with switch.

(2) A special tool included with the safety interlock switch enables forced opening of the interlocking mechanism by authorized personnel, allowing withdrawal of the actuating key and subsequent opening of the NC safety contacts (auxiliary release).

(3) Actuating keys to be ordered separately (see page 81)

Other versions: please consult our Customer Care Center.

Safety detection solutions

Safety interlock switches

Key-operated with solenoid, turret head (1)

XCSTE plastic, 1 cable entry

References of actuating keys and guard retaining device



Description	Straight key	Key with wide fixing (2)	Pivoting key	Right-angled key
For XCSTE safety interlock switches	XCSZ11	XCSZ12	XCSZ13	XCSZ14
Weight (kg)	0.015	0.015	0.085	0.025

References of accessories



XCSZ91



XCSZ200

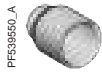

DE9RA1012

Description	For use with	Unit reference	Weight kg
Blanking plugs for operating head slot (Sold in lots of 10)	XCSTE	XCSZ28	0.050
Tool for forced opening of interlocking device (Sold in lots of 10)	XCSTE	XCSZ100	0.050
Padlocking device to help prevent insertion of key, for up to 3 padlocks (padlocks not included)	XCSTE	XCSZ91	0.053
Key centering device (3) (Fixing screws included)	XCSTE	XCSZ200	0.022
1/2" NPT conduit adapter (Sold in lots of 10)	XCSTE	DE9RA1012	0.048
M16 x 1.5 adapter (Sold in lots of 10)	XCSTE	DE9RA1016	0.048

(1) Head adjustable in 90° steps through 360°. Blanking plug for operating head slot included with switch.

(2) 2 key lengths, XCSZ12: L = 40 mm, XCSZ15: L = 29 mm.

(3) Not for use with XCSZ91.

Other versions: please consult our Customer Care Center.

Safety detection solutions

Safety interlock switches

Key-operated with solenoid, turret head

XCSTE plastic, 1 cable entry

Dimensions

Safety interlock switches

XCSTE●●●●

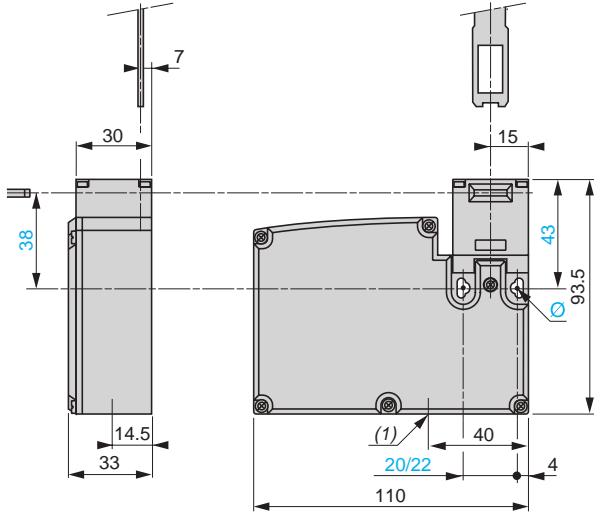

(1) 1 tapped entry for cable gland

Ø: 2 elongated holes Ø 4.3 x 8.3 on 22 centers, 2 holes Ø 4.3 on 20 centers

Actuating key centering device

XCSZ200

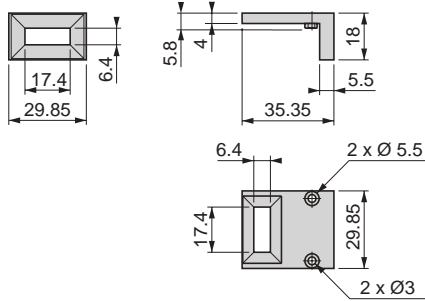

1/2" NPT conduit adapter

DE9RA1012

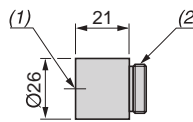

(1) Tapped entry for 1/2" NPT conduit

(2) Pg 11 threaded shank

M16 x 1.5 adapter

DE9RA1016

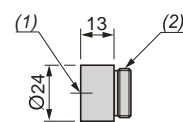

(1) M16 x 1.5 tapped entry

(2) Pg 11 threaded shank

Actuating keys

XCSZ11

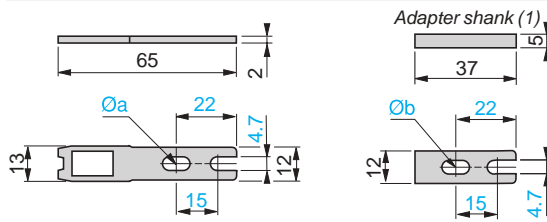

(1) Adapter (included with XCSZ11 actuating key) for replacing, without drilling an additional fixing hole, an XCKT safety interlock switch with XCKY01 actuating key by an XCSTA safety interlock switch with XCSZ11 actuating key.

Ø a: 2 elongated holes Ø 4.7 x 10

Ø b: 1 elongated hole for M4 or M4.5 screw

XCSZ12, XCSZ15

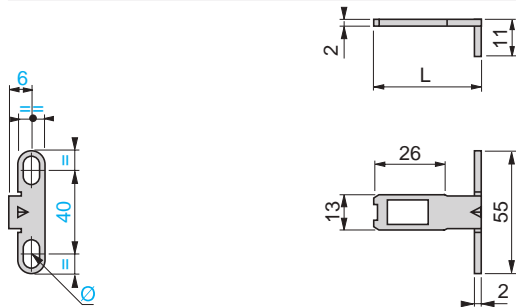

Ø: 2 elongated holes Ø 4.7 x 10

L = 40 mm (XCSZ12) or 29 mm (XCSZ15)

XCSZ13

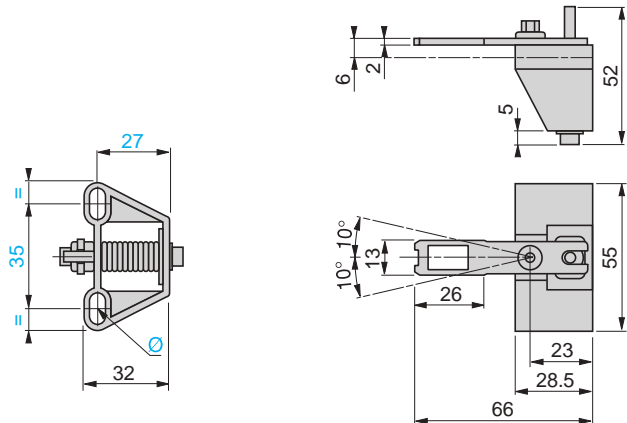

Ø: 2 elongated holes Ø 4.7 x 10

XCSZ14

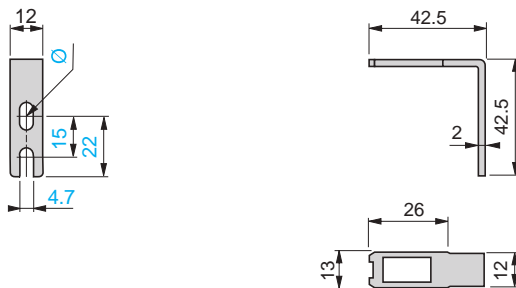

Ø: 1 elongated hole Ø 4.7 x 10

Dimensions (continued)

Operating radius required for actuating key

XCSZ11

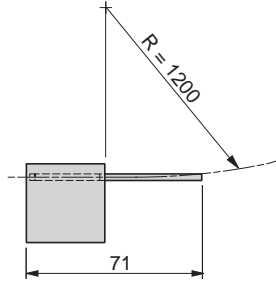
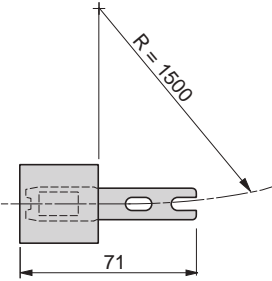

XCSZ12, XCSZ15

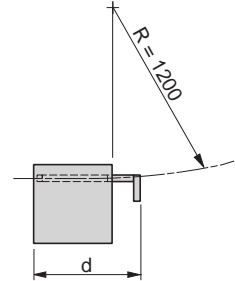
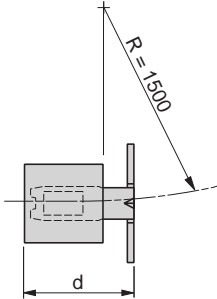

d = 46 mm (XCSZ12) or 35 mm (XCSZ15)

XCSZ13

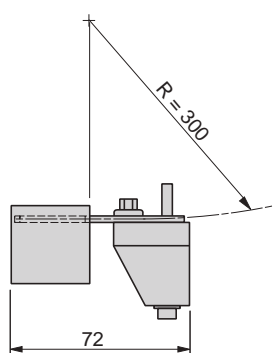
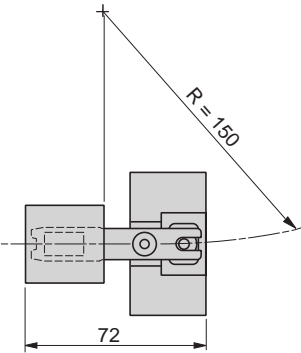

XCSZ14

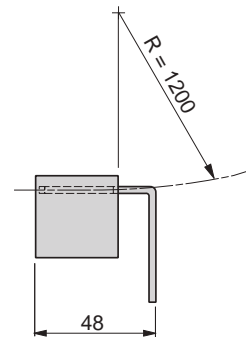
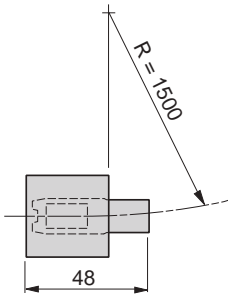

R = minimum radius

Setting-up

Functional diagrams

XCSTE5●●●

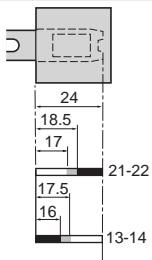

XCSTE6●●●

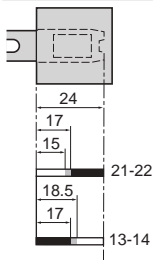

XCSTE7●●●

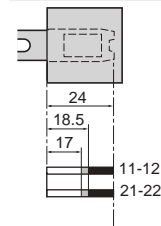

Contact operation

■ Closed

□ Open

■ Transient state

Safety detection solutions

Safety interlock switches

Key-operated with solenoid, turret head

XCSTE plastic, 1 cable entry

Schemes (continued)

Contact states are represented with the actuating key inserted and the solenoid not energized.

Note: These schemes are given as examples only, the designer should refer to the relevant safety standards for guidance.

Wiring to PL=d, category 3 conforming to EN/ISO 13849-1

Example with 2-pole NC + NO contact with mixed redundancy of the contacts and the associated control relays. To activate K1, it is necessary to remove and re-insert the actuating key when the supply is switched on.

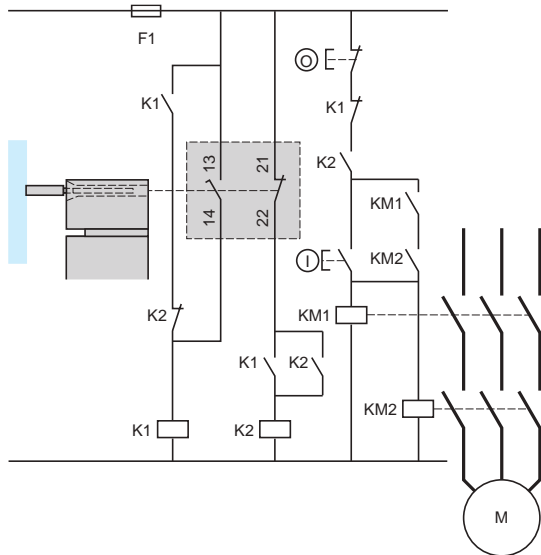

Wiring to PL=e, category 4 conforming to EN/ISO 13849-1 and SIL 3 conforming to EN/IEC 61508

(The safety interlock switch should be used in conjunction with a safety limit switch to give electrical/mechanical redundancy)

Method for machines with long rundown time (high inertia)

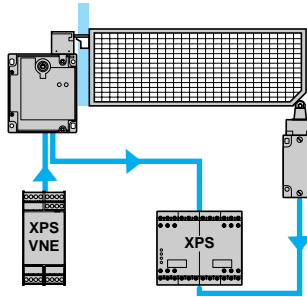

Interlocking device for actuating key fitted on guard and zero speed detection.

Wiring to PL=b, category 1 conforming to EN/ISO 13849-1

Wiring examples with protection fuse to help prevent shunting of the NC contact, due to either cable damage or tampering.

Locking on de-energization

NC + NO
XCSTE53●●

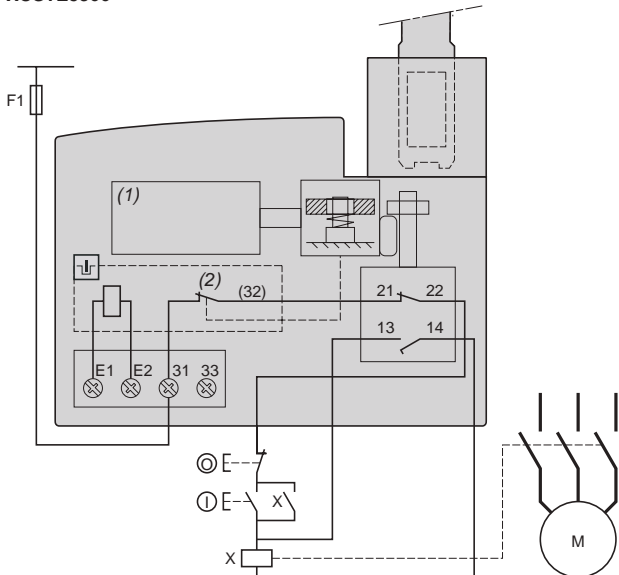

(1) Solenoid

(2) Auxiliary contact

E1-E2: Solenoid supply

13-14: Safety contact for detecting a possible shunt on 21-22 NC contact

Locking on energization

NC + NO
XCSTE55●●

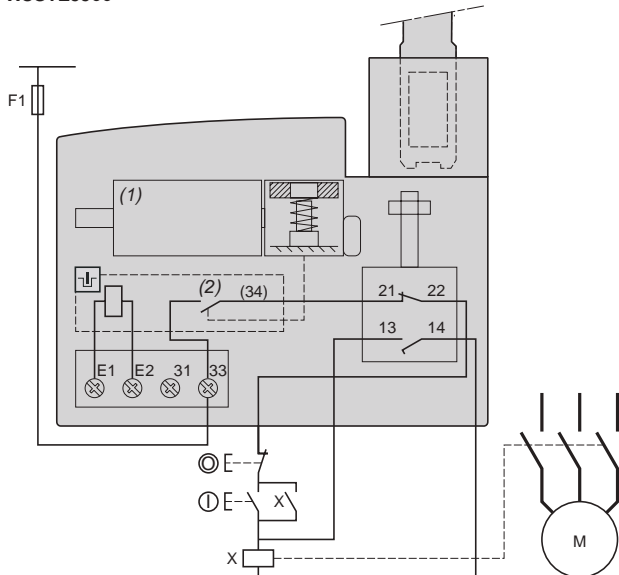

(1) Solenoid

(2) Auxiliary contact

E1-E2: Solenoid supply

13-14: Safety contact for detecting a possible shunt on 21-22 NC contact

Schemes (continued)

Contact states are represented with the actuating key inserted and the solenoid not energized.

Note: These schemes are given as examples only, the designer should refer to the relevant safety standards for guidance.

Wiring to PL=d, category 3 conforming to EN/ISO 13849-1

Wiring examples with redundancy for the safety interlock switch contacts, without monitoring or redundancy in the power circuit

Locking on de-energization

NC + NC
XCSTE73●●

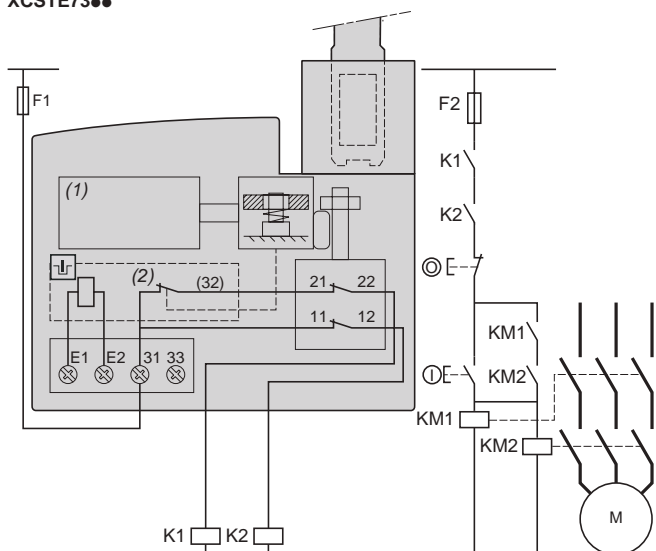

(1) Solenoid

(2) Solenoid auxiliary contact

E1-E2: Solenoid supply

21-22 and 11-12: Redundant Safety contacts: key position monitoring

Locking on energization

NC + NC
XCSTE75●●

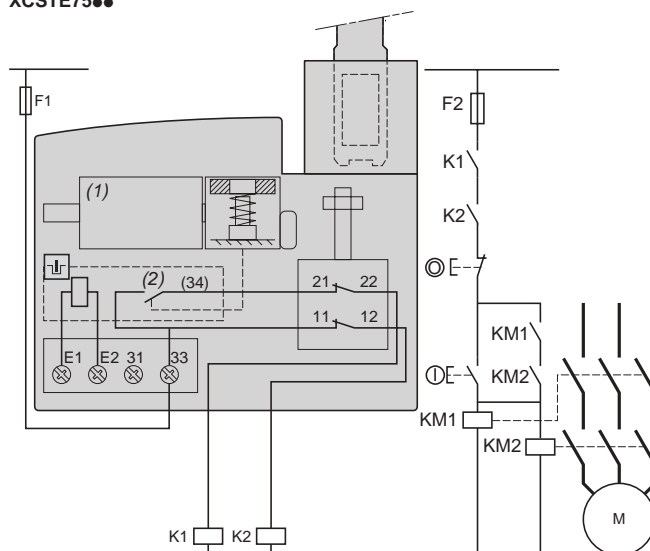

(1) Solenoid

(2) Solenoid auxiliary contact

E1-E2: Solenoid supply

21-22 and 11-12: Redundant Safety contacts: key position monitoring

Safety detection solutions

Contactless RFID safety switches

XCSR standalone, daisy-chain and single models

Unique code (high level coding)

Standalone models

- Unique code, high-level coding conforming to EN/ISO 14119
- 2 OSSD safety outputs
- Embedded EDM (external device monitoring)
- Manual or automatic start/restart depending on model
- Male 8-pin M12 connector
- IP 69K
- Numerous possible mounting configurations due to rotary transponder and symmetrical design
- Operation possible without safety control unit

Category 4/PL = e and SIL3

XCSRC11AM12 and XCSRC11MM12
Unique pairing (1)



XCSRC31AM12 and XCSRC31MM12
Two new pairings possible (2)



Page 88

Daisy-chain models for series connection

- Unique code, high-level coding conforming to EN/ISO 14119
- Up to 20 switches can be connected in series without impacting the safety level
- 2 OSSD safety outputs
- 2 male 5-pin M12 connectors for direct series connection
- IP 69K
- Diagnosis of the whole chain of switches possible using the optional diagnostic module (see page 91)
- Numerous possible mounting configurations due to rotary transponder and symmetrical design

Category 4/PL = e and SIL3 (if combined with an appropriate safety control unit category 4/PL = e - SIL3)

XCSRC12M12
Unique pairing (1)



XCSRC32M12
Two new pairings possible (2)



Page 89

Single models for point-to-point connections

- Unique code, high-level coding conforming to EN/ISO 14119
- Point-to-point connection to a safety controller or safety PLC
- 2 OSSD safety outputs
- Male 5-pin M12 connector
- IP 69K
- Numerous possible mounting configurations due to rotary transponder and symmetrical design

Category 4/PL = e and SIL3 (if combined with an appropriate safety control unit category 4/PL = e - SIL3)

XCSRC10M12
Unique pairing (1)



XCSRC30M12
Two new pairings possible (2)



Page 90

(1) The reader and transponder are supplied together, already factory-paired with a unique code.

(2) For these switches, the reader and transponder are supplied together, already factory-paired with a unique code. However, the reader can be re-paired (twice only) with a new (blank) transponder (see page 91). Once the new transponder has been paired, the previous transponder is no longer usable. A new blank transponder can only be paired once.

Type of contactless RFID switch		XCSR \bullet 1AM12 and XCSR \bullet 1MM12 standalone models	XCSR \bullet 12M12 and XCSR \bullet 32M12 daisy-chain models	XCSR \bullet 10M12 and XCSR \bullet 30M12 single models
Environment				
Conforming to standards		EN/ISO 14119 (High level of coding), EN/IEC 60947-5-2, EN/IEC 60947-5-3 UL 508 (1), CSA C22.2 SIL 3 (IEC 61508), SILCL 3 (IEC 62061), PL _e -Cat. 4 (EN ISO 13849-1)		
Product certifications		CE, cULus, TÜV, FCC, EAC, IC, RCM, E2, ECOLAB		
Maximum safety level (2)		SIL3 conforming to EN/IEC 61508, PL _e =e, category 4 conforming to EN/ISO 13849-1		
Ambient air temperature	For operation	-25...+70 °C		
	For storage	-40...+85 °C		
Vibration resistance	Conforming to EN/IEC 60068-2-6	10 gn (10...150 Hz)		
Shock resistance	Conforming to EN/IEC 60068-2-27	30 gn, 11 ms		
Protection against electric shock	Conforming to EN/IEC 61140	Class III		
Degree of protection	Conforming to EN/IEC 60529	IP 65, IP 66, IP 67		
	Conforming to DIN 40050	IP 69K		
Materials		Thermoplastic housing (Valox™)		
Characteristics				
Rated operating characteristics (3)		U _e : 24 V $\overline{\text{---}}$, -20%...+10%, I _e : $\overline{\text{---}}$ 60 mA (without load)		
Rated impulse withstand voltage (U _{imp})	Conforming to EN/IEC 60947-5-2	0.8 kV		
Integrated output protection		Short-circuit protection		
Connection	Conforming to EN/IEC 60947-5-2-A3 and EN/IEC 61076	M12 connector (A coding)		
Safety outputs 2 PNP NO OSSDs (output signal switching devices)	Maximum current	400 mA	200 mA	200 mA
Maximum switching frequency		0.5 Hz		
Delay	Power-on	< 5 s		
Typical response time (on transponder entry into operating zone)		250 ms	120 ms + 50 ms per additional switch	120 ms
Risk time (on transponder exit from operating zone)		< 120 ms	< 120 ms + 18 ms per additional switch	< 120 ms
Probability of dangerous failure per hour PFH _b	Conforming to EN/ISO13849-1 and EN/IEC 62061	5 x 10 ⁻¹⁰		
Tightening torque	M4 retaining screw	1.5 N.m/13 lb-in		
	M12 connectors	1 N.m/0.88 lb-in		
Mission time (TM)		20 years		
RFID protocol		Based on ISO 15693		
Functions				
Functions		<ul style="list-style-type: none"> - Operation possible without safety control unit - Manual monitored or automatic restart depending on model - External device monitoring (EDM) 	<ul style="list-style-type: none"> - Integrated series connections - Connection to a safety interface (safety relay, for example) - Series diagnostics (with XCSR\bulletD210MDB diagnostic module) 	<ul style="list-style-type: none"> - Point-to-point connection to a safety interface (safety controller or safety PLC, for example)

(1) The switch safety function has been assessed by TÜV Nord, not by UL.

(2) With an appropriate, correctly connected safety control system for daisy-chain and single models.

(3) Use a safety extra-low voltage (SELV) or protected extra-low voltage (PELV) power supply.

Safety detection solutions

Contactless RFID safety switches

XCSR standalone model

Unique code (high level coding)

Type

Standalone contactless RFID safety switches



Certified

Connection via M12 connector



References

Composition	Functions	Unique pairing	Two new pairings possible	Weight kg
<ul style="list-style-type: none"> ■ Reader ■ Multiposition sensor transponder ■ Transponder and reader factory paired ■ 4 blanking plugs ■ Quick Start Guide ■ EU declaration of conformity 	EDM, automatic restart	XCSRC11AM12	XCSRC31AM12	0.100
	EDM, monitored manual restart (1)	XCSRC11MM12	XCSRC31MM12	0.100

Detection characteristics (2)

Typical operating sensing distance (for detection of transponder presence)	15 mm
Assured operating sensing distance	Sao: 10 mm
Typical release sensing distance (for detection of transponder absence)	18 mm
Assured release distance	Sar: 35 mm
Repeat accuracy	≤ 10% x Sr
Hysteresis	3% x Sr ≤ H ≤ 20% x Sr (Sr: real sensing distance)

Output states

Output states shown are with the dedicated transponder positioned in front of the reader.

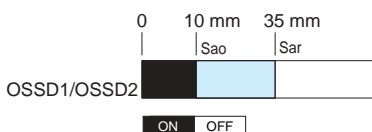

- Outputs closed
- Outputs open
- Transient state

Sao: Assured operating sensing distance
Sar: Assured release distance
Conforming to EN/IEC 60947-5-3

Connections

8-pin M12 connector

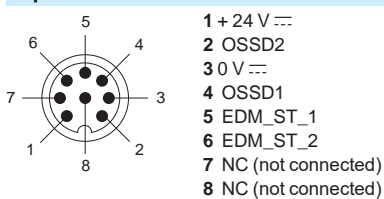

(1) The start command is effective after the operator has pressed and released the start button.

(2) These values are given for a face-to-face mounting configuration of the reader and transponder on a non-magnetic support, without misalignment between the transponder and the reader, and at an ambient temperature between +20 and +25 °C.

Safety detection solutions

Contactless RFID safety switches

XCSR daisy-chain model

Unique code (high level coding)

Type

Daisy-chain contactless RFID safety switches



Certified

Connection via M12 connectors



References

Composition	Unique pairing	Two new pairings possible	Weight kg
<ul style="list-style-type: none"> ■ Reader ■ Multiposition sensor transponder ■ Transponder and reader factory-paired ■ 4 blanking plugs ■ Quick Start Guide ■ EU declaration of conformity 	XCSRC12M12	XCSRC32M12	0.100

Detection characteristics (1)

Typical operating sensing distance (for detection of transponder presence)	15 mm
Assured operating sensing distance	Sao: 10 mm
Typical release sensing distance (for detection of transponder absence)	18 mm
Assured release distance	Sar: 35 mm
Repeat accuracy	≤ 10% x Sr
Hysteresis	3% x Sr ≤ H ≤ 20% x Sr (Sr: real sensing distance)

Output states

Output states shown are with the dedicated transponder positioned in front of the reader.

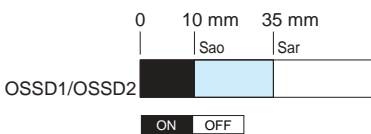

- Outputs closed
- Outputs open
- Transient state

Sao: Assured operating sensing distance
Sar: Assured release distance
Conforming to EN/IEC 60947-5-3

Connections

2 x 5-pin M12 connectors

Output connector

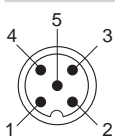

- 1 +24 V $\overline{\text{---}}$
- 2 OSSD2 (O2)
- 3 0 V $\overline{\text{---}}$
- 4 OSSD1 (O1)
- 5 Diagnosis Out (Do)

Input connector

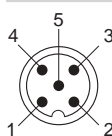

- 1 +24 V $\overline{\text{---}}$
- 2 INPUT 2 (I2)
- 3 0 V $\overline{\text{---}}$
- 4 INPUT 1 (I1)
- 5 Diagnosis In (Di)

(1) These values are given for a face-to-face mounting configuration of the reader and transponder on a non-magnetic support, without misalignment between the transponder and the reader, and at an ambient temperature between +20 and +25 °C.

Safety detection solutions

Contactless RFID safety switches

XCSR single model

Unique code (high level coding)

Type

Single contactless RFID safety switches



Certified

Connection via M12 connector



References

Composition	Unique pairing	Two new pairings possible	Weight kg
<ul style="list-style-type: none"> ■ Reader ■ Multiposition sensor transponder ■ Transponder and reader factory-paired ■ 4 blanking plugs ■ Quick Start Guide ■ EU declaration of conformity 	XCSRC10M12	XCSRC30M12	0.100

Detection characteristics (1)

Typical operating sensing distance (for detection of transponder presence)	15 mm
Assured operating sensing distance	Sao: 10 mm
Typical release sensing distance (for detection of transponder absence)	18 mm
Assured release distance	Sar: 35 mm
Repeat accuracy	≤ 10% x Sr
Hysteresis	3% x Sr ≤ H ≤ 20% x Sr (Sr: real sensing distance)

Output states

Output states shown are with the dedicated transponder positioned in front of the reader.

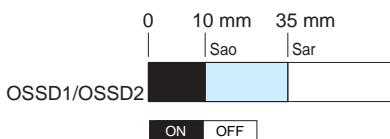

- Outputs closed
- Outputs open
- Transient state

Sao: Assured operating sensing distance
 Sar: Assured release distance
 Conforming to EN/IEC 60947-5-3

Connections

5-pin M12 connector

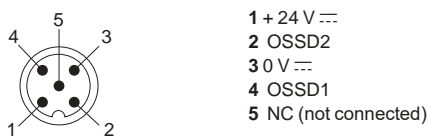

(1) These values are given for a face-to-face mounting configuration of the reader and transponder on a non-magnetic support, without misalignment between the transponder and the reader, and at an ambient temperature between +20 and +25 °C.

XCS_616_CPSC16004



XCSR210MDB

Diagnostic module for daisy-chain RFID safety switches

The **XCSR210MDB** module interprets the diagnostic data from the whole chain of switches and makes this information available in Modbus registers. There are two RJ45 Modbus communication connectors available for connecting external peripheral devices (such as an HMI terminal, for example).

Main characteristics of the diagnostic function:

- It provides the state of all the **XCSRC•M12** switches monitored by the safety chain.
- It identifies which protection devices are open or closed.
- It helps to prevent a restart of the machine if the chain has been unintentionally or deliberately tampered with; if an error has been detected on any of the safety switches; or if any of the wiring becomes disconnected.
- It detects if the **XCSRZE** loopback device is not connected and helps to prevent restarting until the loopback device has been reconnected and a new power cycle completed.

Description	For RFID safety switches	Reference	Weight kg
<ul style="list-style-type: none"> ■ Modbus RTU ■ 2 RJ45 outputs ■ 2 LEDs ■ 1 volt-free contact representative of the state of the chain 	XCSRC12M12, XCSRC32M12	XCSR210MDB	0.100

XCS_616_CPSC16004



XCSR2A3

XCS_616_CPSC16005



XCSRZE

Loopback device for daisy-chain RFID safety switches

Description	For RFID safety switches	Reference	Weight kg
M12 connector	XCSRC12M12, XCSRC32M12	XCSRZE	0.020

Blank transponder for new pairing

Composition	For RFID safety switches	Reference	Weight kg
<ul style="list-style-type: none"> ■ Blank transponder ■ 2 blanking plugs 	XCSRC30M12, XCSRC31AM12, XCSRC31MM12, XCSRC32M12	XCSR2A3	0.020

XCS_616_CPSC16016



XCSRZSRC1



XCSRZSTK1

Mounting accessories

Description	For use with	Reference	Weight kg
Mounting supports (supplied with 2 one-way screws, Ø 4 x 12 mm, for mounting the safety switch on the support)	Reader	XCSRZSRC1	0.150
	Transponder	XCSRZSTK1	0.050

Description	Length mm	Reference	Weight kg
One-way screws for mounting Ø 4 mm safety switches (pack of 10 screws)	14	XCSZ71	0.020
	35	XCSZ72	0.020

Characteristics

Cable type		XZCP29P12L●● XZCP29P12L●●	XZCR1111064D●●	XZCP11V12L●● XZCP11V12L●●
Connection type	Screw thread (metal clamping ring)			
Number of contacts		8	5	
Degree of protection	IP 65, IP 67, and IP 69K (with clamping ring correctly tightened)			
Ambient air temperature	Operation	-25...+70 °C		
	Storage	-40...+85 °C		
Connection	Conforming to EN/IEC 60947-5-2	PUR cable, Ø 6.4 mm, wire c.s.a.: 8 x 0.34 mm ²	PUR cable, Ø 5 mm, wire c.s.a.: 5 x 0.34 mm ²	
	Nominal current	2 A		
Insulation resistance	> 10 ⁹ Ω			
Contact resistance	≤ 5 mΩ			

References

F19_ACC_CPFJR16052



XZCP29P12L●●

F19_ACC_CPFJR16053



XZCP29P12L●●

F19_ACC_CPFJR16056



XZCR1111064D●●

F19_ACC_CPFJR16049



XZCP11V12L●●

F19_ACC_CPFJR16050



XZCP11V12L●●

Description	Pins	For use with	Type	Length m	Reference	Weight kg
Pre-wired connectors for standalone RFID safety switches						
Pre-wired connectors with female M12 connector (A coding)	8	XCSRC11AM12, XCSRC31AM12, XCSRC11MM12, XCSRC31MM12	Straight	2	XZCP29P12L2	0.010
				5	XZCP29P12L5	0.250
				10	XZCP29P12L10	0.500
				20	XZCP29P12L20	1.000
			Elbowed	2	XZCP53P12L2	0.010
				5	XZCP53P12L5	0.250
				10	XZCP53P12L10	0.500
				20	XZCP53P12L20	1.000
Jumper cables for daisy-chain RFID safety switches						
Jumper cables with 2 female M12 connectors (A coding)	5	XCSRC12M12, XCSRC32M12	Straight	0.3	XZCR1111064D03	0.060
				3	XZCR1111064D3	0.180
				5	XZCR1111064D5	0.300
				10	XZCR1111064D10	0.600
				25	XZCR1111064D25	1.500
Pre-wired connectors for daisy-chain and single RFID safety switches (1)						
Pre-wired connectors with female M12 connector (A coding)	5	XCSRC10M12, XCSRC30M12, XCSRC12M12, XCSRC32M12	Straight	2	XZCP11V12L2	0.010
				5	XZCP11V12L5	0.250
				10	XZCP11V12L10	0.500
				20	XZCP11V12L20	1.000
			Elbowed	2	XZCP12V12L2	0.010
				5	XZCP12V12L5	0.250
				10	XZCP12V12L10	0.500
				20	XZCP12V12L20	1.000

(1) For connecting the last switch in the chain (XCSRC12M12 or XCSRC32M12) to the safety control unit.

Safety switches

Reader with connection via M12 connector

XCSRC●0M12, XCSRC●1AM12 and XCSRC●1MM12

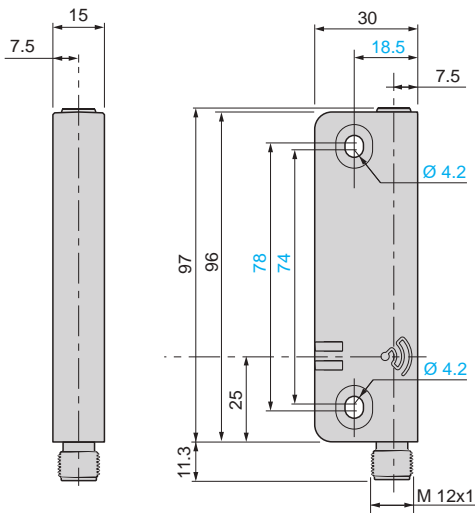

Reader with connection via 2 x M12 connectors

XCSRC●2M12

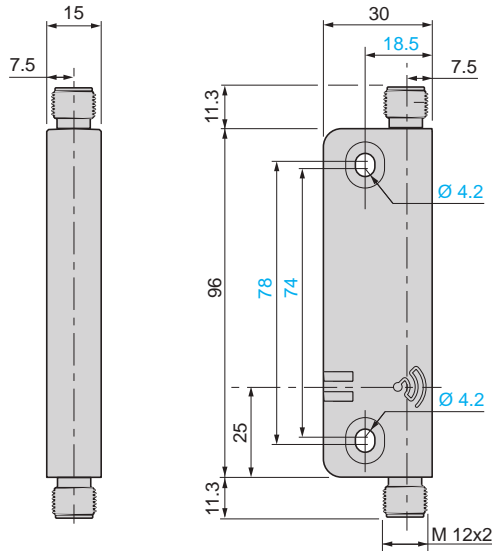

Transponder

XCSRK2A3

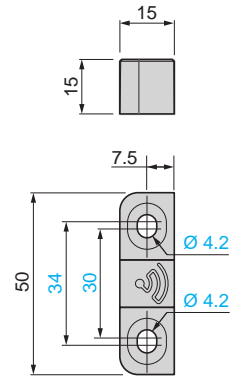

Accessories

Mounting support for reader

XCSRZSRC1

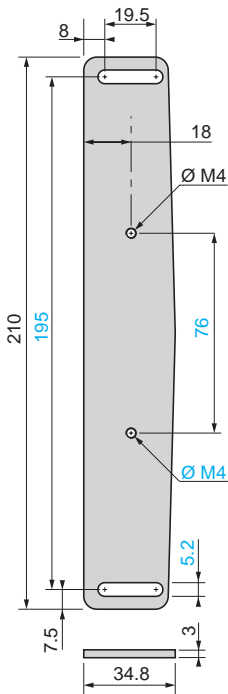

Mounting support for transponder

XCSRZSTK1

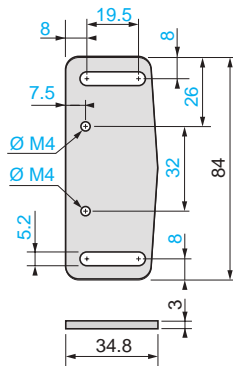

Diagnostic module

XCSR210MDB

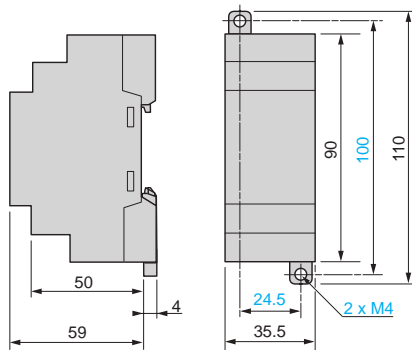

Loopback device

XCSRZE

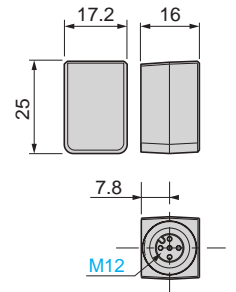

Safety detection solutions

Contactless RFID safety switches
XCSR standalone, daisy-chain and single models

Mounting

Examples of face-to-face mounting configurations (recommended)

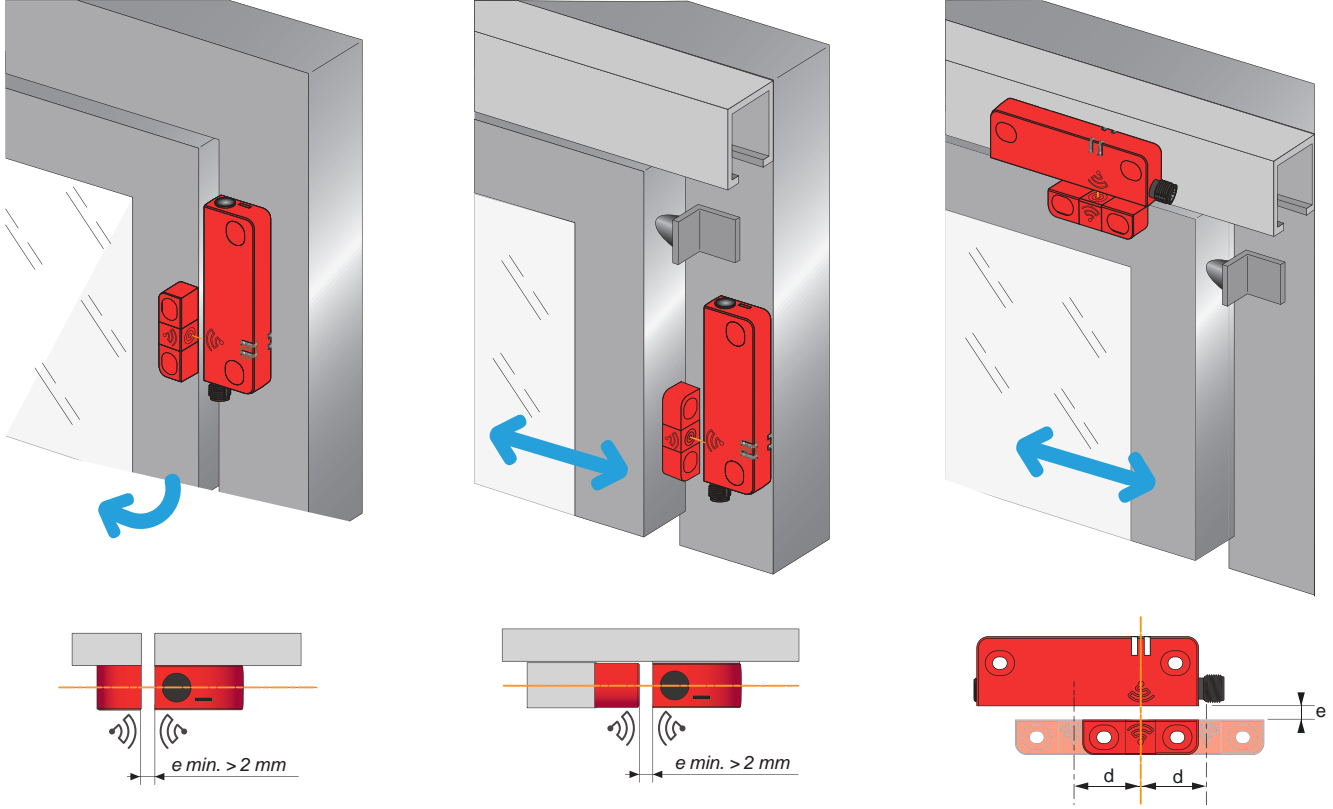

e: minimum recommended mounting distance between reader and transponder

e min. > 2 mm
d: detection limit

Example of side-by-side mounting

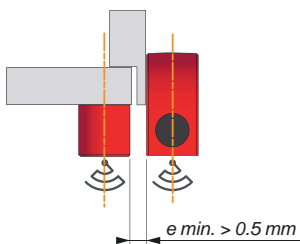
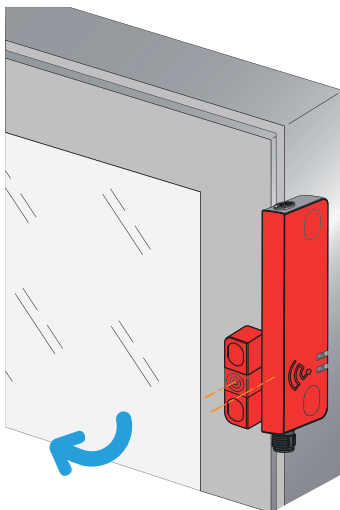

e: minimum recommended mounting distance between reader and transponder

Minimum mounting distances between safety switches

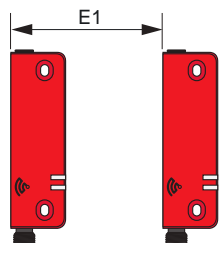

$E1 \text{ min.} = 120 \text{ mm}$



$E2 \text{ min.} = 160 \text{ mm}$

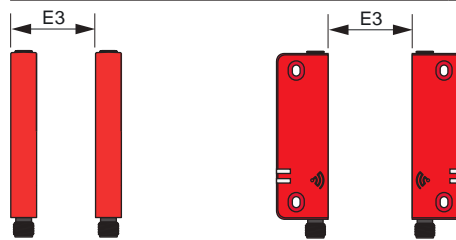

$E3 \text{ min.} = 120 \text{ mm}$

Detection curves

Face-to-face mounting (recommended configuration)

Sao and Sar sensing distances along Y axis as a function of Z
Longitudinal misalignment for X = 0

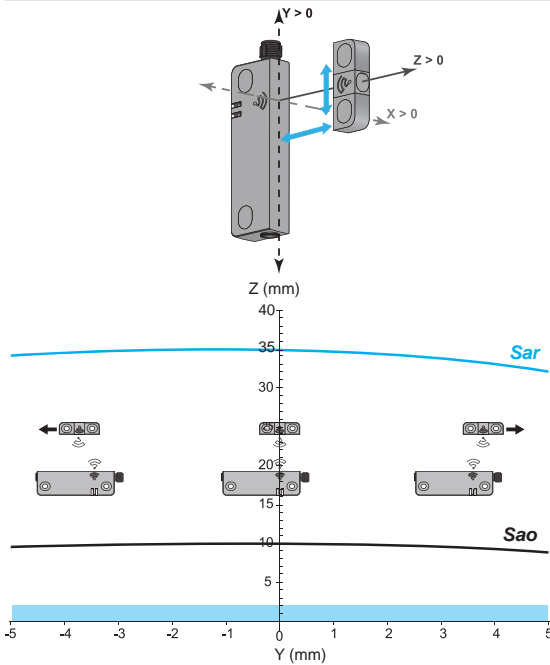

Sao and Sar sensing distances along X axis as a function of Z
Transverse misalignment for Y = 0

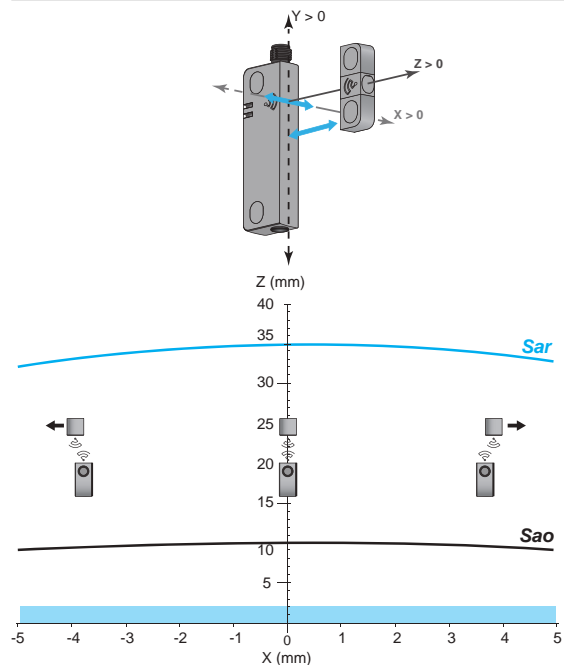

Side-by-side mounting

Sao and Sar sensing distances along Y axis as a function of X
Longitudinal misalignment for Z = 0

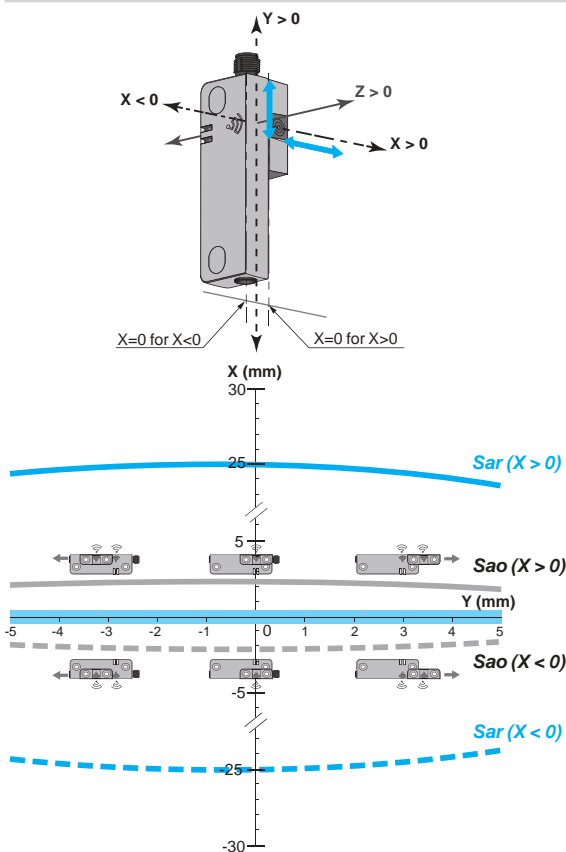

Sao and Sar sensing distances along Z axis as a function of X
Transverse misalignment for Y = 0

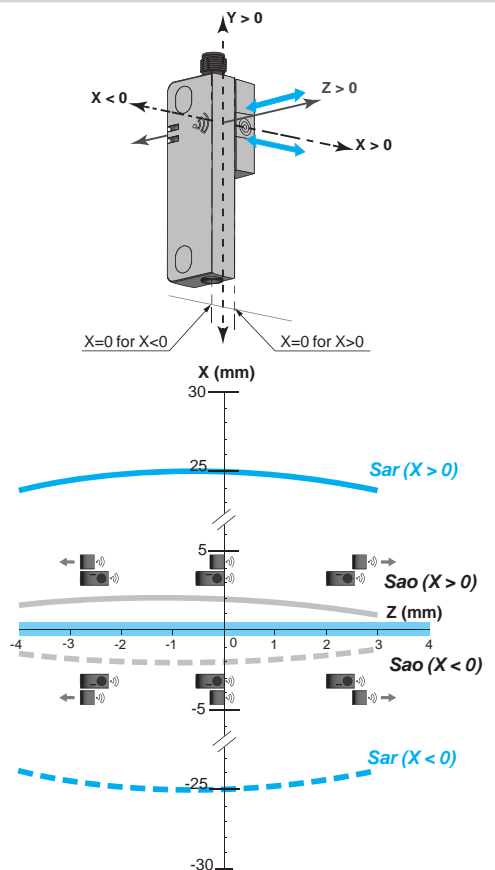

Sao: Assured operating sensing distance

Sar: Assured release distance

: e: minimum recommended mounting distance between reader and transponder

Schemes Note: these schemes are given as examples only, the designer should refer to the relevant safety standards for guidance.

Standalone contactless RFID safety switches: XCSR11AM12, XCSR11MM12, XCSR31AM12 and XCSR31MM12

Example of Category 4/PL = e/SIL 3 connection, with monitored start (1) and monitoring loop for contactors (EDM)

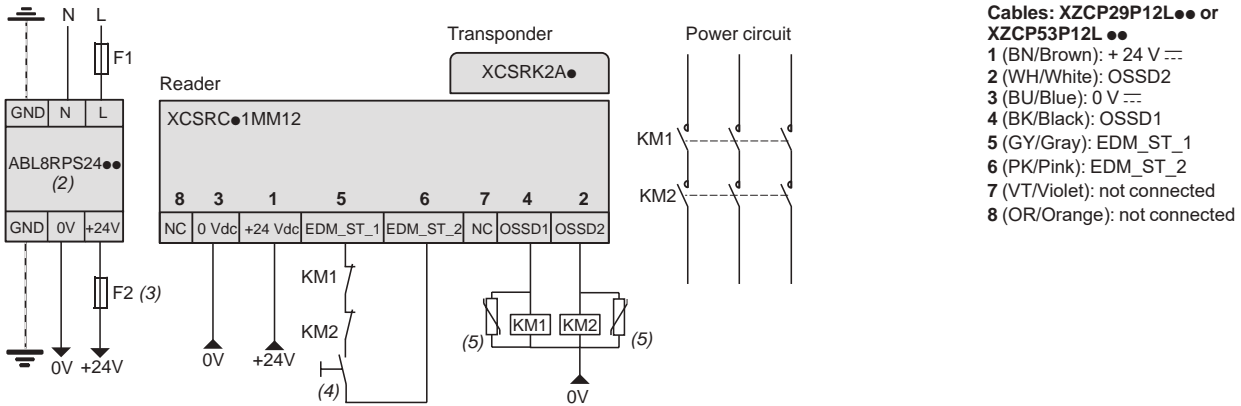

- Cables: XZCP29P12L or XZCP53P12L**
- 1 (BN/Brown): + 24 V
 - 2 (WH/White): OSSD2
 - 3 (BU/Blue): 0 V
 - 4 (BK/Black): OSSD1
 - 5 (GY/Gray): EDM_ST_1
 - 6 (PK/Pink): EDM_ST_2
 - 7 (VT/Violet): not connected
 - 8 (OR/Orange): not connected

- (1) The restart command is effective after the operator has pressed and released the restart button. See Note (4).
- (2) Schneider Electric product. The power supply should meet the requirements of standard IEC 60204-1 relating to safety extra-low voltage (SELV) or protected extra-low voltage (PELV) power supplies.
- (3) 1 A max.
- (4) Restart button.
- (5) The use of arc suppressors is recommended for KM1 and KM2.

Daisy-chain contactless RFID safety switches: XCSR12M12 and XCSR32M12

Example of Category 4/PL = e/SIL 3 series connection to an XPSUAF

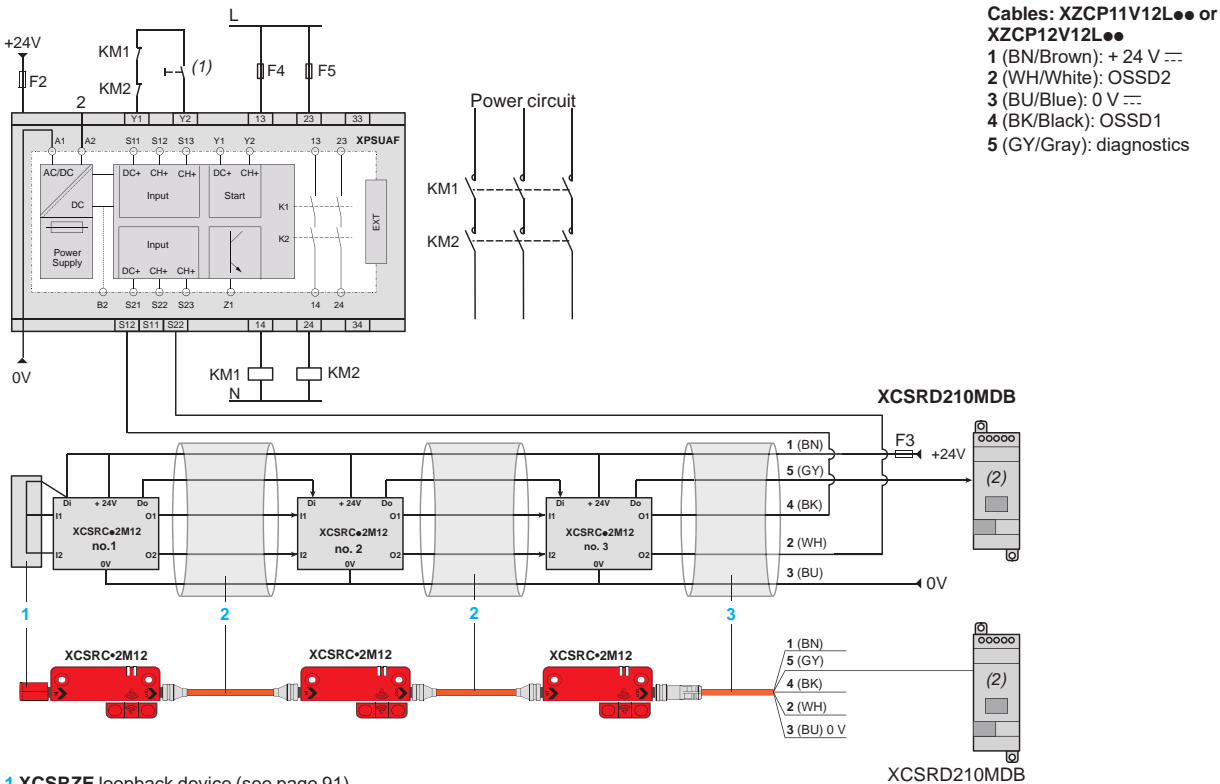

- Cables: XZCP11V12L or XZCP12V12L**
- 1 (BN/Brown): + 24 V
 - 2 (WH/White): OSSD2
 - 3 (BU/Blue): 0 V
 - 4 (BK/Black): OSSD1
 - 5 (GY/Gray): diagnostics

- 1 XCSRZE loopback device (see page 91)
- 2 XZCR1111064D jumper cables (see page 92)
- 3 XZCP11V12L or XZCP12V12L pre-wired connectors (see page 92)

- A1, A2 Power supply
- Y1 Control output (DC+) of start input
- Y2 Input channel (CH+) of start input
- S11, S21 Control outputs (DC+) of safety-related inputs
- S12, S13, S22, S23 Input channels (CH+) of safety-related inputs

- (1) The start function is configured by means of the XPSUAF start function selector.
- (2) The diagnostic module (XCSR210MDB), every XCSR2M12 switch, and the XPSUAF safety control unit should all be powered by the same power supply.

Single contactless RFID safety switches: XCSRC10M12 and XCSRC30M12

Example of Category 4/PL = e/SIL 3 connection to an XPSMCMCP0802 safety controller

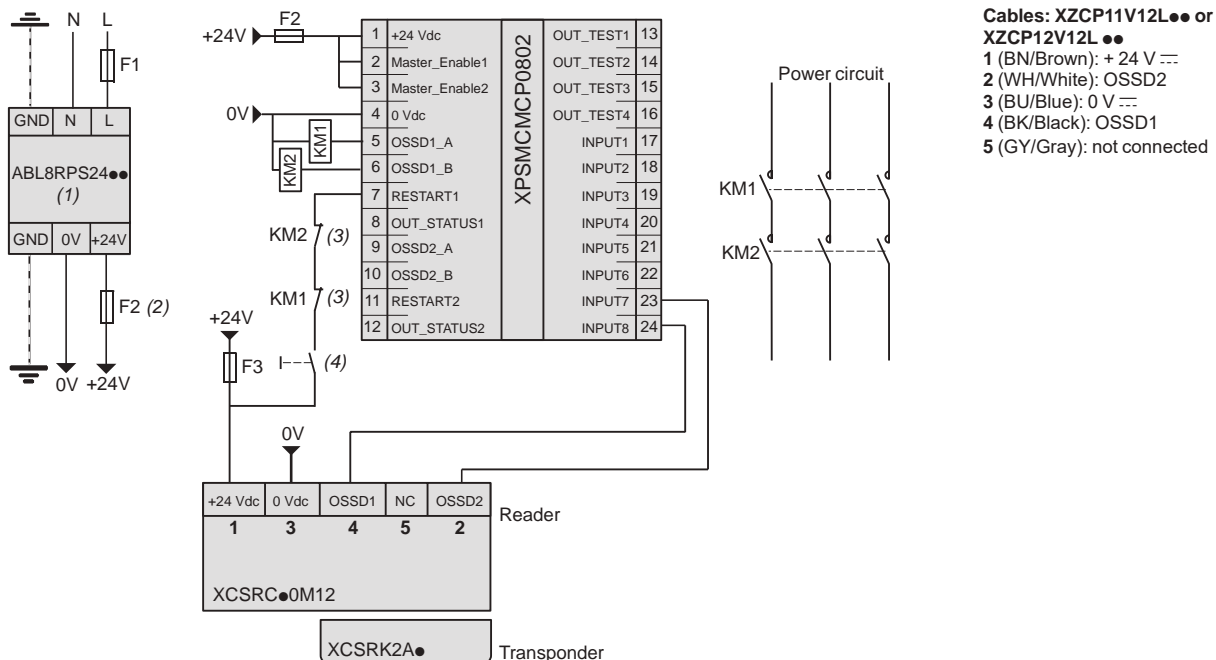

(1) Schneider Electric product. The power supply should meet the requirements of standard IEC 60204-1 relating to safety extra-low voltage (SELV) or protected extra-low voltage (PELV) power supplies.
 (2) 1 A max.
 (3) Monitoring of contactors (EDM: external device monitoring).
 (4) Restart button.

Safety detection solutions

Safety coded magnetic switches

XCSDMC compact rectangular

XCSDMP standard rectangular, XCSDMR cylindrical

Plastic

XCSDMC

Rectangular, compact: 51 x 16 x 7 (mm)

Pre-cabled connection



Page 100

Connector on flying lead connection



Page 101

XCSDMP

Rectangular, standard: 88 x 25 x 13 (mm)

Pre-cabled connection



Page 100

Connector on flying lead connection



Page 101

XCSDMR

Cylindrical, diameter: 30, length: 38.5 (mm)

Pre-cabled connection



Page 100

Connector on flying lead connection



Page 101

Environment		
Conformity to standards	Products	EN/IEC 60947-5-1, UL 508, CSA C22-2 no. 14
	Machine assemblies	EN/IEC 60204-1, EN/ISO 14119 (Low Level of Coding)
Product certifications		UL, CSA, EAC, ECOLAB
Maximum safety level (1)		PL=e, category 4 conforming to EN/ISO 13849-1 and SIL 3 conforming to EN/IEC 61508
Reliability data B_{10D}		50,000,000 (value given for a service life of 20 years, limited by mechanical or contact wear)
Ambient air temperature	For operation	-25...+85 °C
	For storage	-40...+85 °C
Vibration resistance		10 gn (10...150 Hz) conforming to EN/IEC 60068-2-6
Shock resistance		30 gn (11 ms) conforming to EN/IEC 60068-2-27
Sensitivity to magnetic fields		≥ 0.3 mT
Electric shock protection		Class II conforming to EN/IEC 61140
Degree of protection	Conforming to IEC 60529	IP 66 and IP 67 for coded magnetic switches with pre-cabled connection IP 67 for coded magnetic switches with connector on flying lead connection
Materials		Thermoplastic case (PBT) PVC cable (ROHS)
Contact block characteristics		
Rated operational characteristics		Ue: 24 V $\overline{---}$, Ie: 100 mA max.
Rated insulation voltage (Ui)		Ui: 100 V $\overline{---}$
Rated impulse withstand voltage (U imp)		2.5 kV conforming to EN/IEC 60947-5-1
Resistance across terminals	Contact with LED	57 Ω
	Contact without LED	10 Ω
Protection (of the fuse for the safety control unit protection)		External cartridge fuse: 500 mA gG (gl) (use a UL-recognized Type CC fuse in the United States). Optionally, in series with each switch contact to avoid damage to the internal protection in case of misuse.
Connection	XCSDMC 2-contact model	Pre-cabled, 4 x 0.25 mm ² , length: 2, 5 or 10 m depending on model or 4-pin male M8 connector on 0.15 m flying lead
	XCSDMP 2-contact model	Pre-cabled, 4 x 0.25 mm ² , length: 2, 5 or 10 m depending on model or 4-pin male M12 connector on 0.15 m flying lead
		3-contact model
	XCSDMR 2-contact model	Pre-cabled, 4 x 0.25 mm ² , length: 2, 5 or 10 m depending on model or 4-pin male M12 connector on 0.15 m flying lead
Contact material		Rhodium
Electrical durability		1.2 million operating cycles
Switching capacity	Contact with LED	5...100 mA
	Contact without LED	0.1...100 mA
Insulation resistance		1000 MΩ
Maximum breaking capacity	Contact with LED	3 VA
	Contact without LED	10 VA
Maximum switching frequency		150 Hz

(1) Using an appropriate and correctly connected safety control unit.

Safety detection solutions

Coded magnetic safety switches

XCSDMC compact rectangular

XCSDMP standard rectangular, XCSDMR cylindrical

Plastic, pre-cabled

Type of switch	Rectangular		Cylindrical
	Compact 51 x 16 x 7	Standard 88 x 25 x 13	Diameter 30 Length 38.5



References of switches (1) Δ should be used in conjunction with safety control units (see page 106)

Contact states shown are with the magnet positioned in front of the switch

2-pole 1 NC + 1 NO (staggered)		XCSDMC5902	XCSDMP5902	XCSDMR5902
2-pole 2 NC (2) (staggered)		XCSDMC7902	XCSDMP7902	XCSDMR7902
3-pole 1 NC + 2 NO (1 NO staggered)		—	XCSDMP5002	—
3-pole 2 NC + 1 NO (2) (1 NC staggered)		—	XCSDMP7002	—
2-pole 1 NC + 1 NO (staggered)		XCSDMC5912	XCSDMP5912	XCSDMR5912
2-pole 2 NC (2) (staggered)		XCSDMC7912	—	XCSDMR7912
3-pole 1 NC + 2 NO (1 NO staggered)		—	XCSDMP5012	—
3-pole 2 NC + 1 NO (2) (1 NC staggered)		—	XCSDMP7012	—
Weight (kg)		0.101	0.180	0.146

(1) The references of **XCSDM●** switches comprise a coded magnet (XCSZ●1) and a magnetic switch (XCSZ●●). Example: XCSDMP5012 comprises XCSZP1 (magnet) + XCSZP5012 (switch). Only the coded magnets are available as spare parts (see on page 102).

Switch pre-cabled with 2 m long cable. For other cable lengths, replace the last number of the reference (2) with 5 for a 5 m long cable or with 10 for a 10 m long cable.

Example: rectangular, compact switch with 1 NC + 1 NO contacts and 10 m cable becomes **XCSDMC59010**.

(2) To be associated with a safety control unit which allows 2 NC contact monitoring (for example XPSUAF●, XPSUS●, XPSUDN●, etc.).

Complementary characteristics not shown under general characteristics (page 99)

Operating zone	Sao: 5 mm Sar: 15 mm	Sao: 8 mm Sar: 20 mm	Sao: 8 mm Sar: 20 mm
Approach directions	3 directions	3 directions	1 direction

Accessories

See page 102



Safety detection solutions

Coded magnetic safety switches

XCSDMC compact rectangular

XCSDMP standard rectangular, XCSDMR cylindrical

Plastic, connector on flying lead

Type of switch	Rectangular		Cylindrical
	Compact 51 x 16 x 7	Standard 88 x 25 x 13	Diameter 30 Length 38.5
	M8 connector	M12 connector	M12 connector
			

References of switches (1) Δ should be used in conjunction with safety control units (see page 106)

Contact states shown are with the magnet positioned in front of the switch

Contact state	Diagram	XCSDMC	XCSDMP	XCSDMR
2-pole 1 NC + 1 NO (staggered)		XCSDMC590L01M8	XCSDMP590L01M12	XCSDMR590L01M12
2-pole 2 NC (2) (staggered)		XCSDMC790L01M8	XCSDMP790L01M12	XCSDMR790L01M12
3-pole 1 NC + 2 NO (1 NO staggered)		-	XCSDMP500L01M12	-
3-pole 2 NC + 1 NO (2) (1 NC staggered)		-	XCSDMP700L01M12	-
2-pole 1 NC + 1 NO (staggered)		XCSDMC591L01M8	XCSDMP591L01M12	XCSDMR591L01M12
2-pole 2 NC (2) (staggered)		XCSDMC791L01M8	XCSDMP791L01M12	XCSDMR791L01M12
3-pole 1 NC + 2 NO (NO staggered)		-	XCSDMP501L01M12	-
3-pole 2 NC + 1 NO (2) (NC staggered)		-	XCSDMP701L01M12	-
Weight (kg)		0.101	0.180	0.146

(1) The references of **XCSDM** switches comprise a coded magnet (XC SZ●1) and a magnetic switch (XC SZ●●). Only the coded magnets are available as spare parts (see on page 102).

Example: XCSDMC590L01M8 comprises XCSZC1 (magnet) + XCSZC590L01M8 (switch).

(2) To be associated with a safety control unit which allows 2 NC contacts monitoring (for example XPSUAF●, XPSUS●, XPSUDN●, etc.)

Complementary characteristics not shown under general characteristics (page 99)

Operating zone	Sao: 5 mm Sar: 15 mm	Sao: 8 mm Sar: 20 mm	Sao: 8 mm Sar: 20 mm
Approach directions	3 directions	3 directions	1 direction

Accessories

See page 102

Accessories			
Accessories for coded magnetic switches	XCSDMC●●●2 XCSDMC●●●L	XCSDMP●●●2 XCSDMP●●●L	XCSDMR●●●2 XCSDMR●●●L
Fixing clamp	–	–	XSZB130
Weight (kg)	–	–	0.080
Additional coded magnet	XCSZC1	XCSZP1	XCSZR1
Weight (kg)	0.009	0.050	0.018
Non-magnetic shims	XCSZCC (lot of 2)	XCSZCP (lot of 2)	XCSZCR
Weight (kg)	0.008	0.012	0.002

Pre-wired female connectors for connector version switches

Pre-wired connector characteristics

Pre-wired connector type	XZCP0941L●, XZCP1041L●	XZCP29P11L●	XZCP1141L●, XZCP1241L●
Type of connection	Screw thread (metal clamping ring)	Screw thread (metal clamping ring)	Screw thread (metal clamping ring)
Number of contacts	4	8	4
Degree of protection	IP 67 (with clamping ring correctly tightened)		
Ambient air temperature	Static	-35...+90 °C	-35...+90 °C
	Dynamic	-5...+90 °C	-5...+90 °C
Cabling	Ø 5.2 mm cable, wire c.s.a.: 4 x 0.34 mm ²	Ø 5.2 mm cable, wire c.s.a.: 8 x 0.25 mm ²	Ø 5.2 mm cable, wire c.s.a.: 4 x 0.34 mm ²
LED signaling	–	–	–
Nominal voltage	60 V ~, 75 V ~	30 V ~, 36 V ~	250 V ~, 300 V ~
Nominal current	4 A	2 A	4 A
Insulation resistance	> 10 ⁹ Ω	> 10 ⁹ Ω	> 10 ⁹ Ω
Contact resistance	≤ 5 mΩ	≤ 5 mΩ	≤ 5 mΩ

References of pre-wired connectors (For connection to flying lead models)

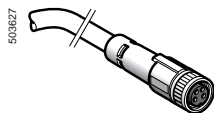

XZCP0941L●

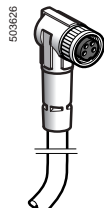

XZCP1041L●

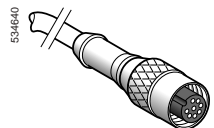

XZCP29P11L●

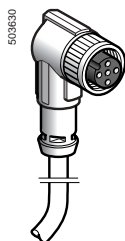

XZCP1241L●

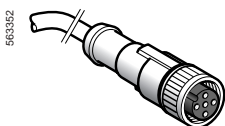

XZCP1141L●

Type of connector	Number of pins	For use with	Type	Cable length m	Reference	Weight kg
Female, M8	4	XCSDMC●9●	Straight	2	XZCP0941L2	0.080
				5	XZCP0941L5	0.180
				10	XZCP0941L10	0.360
			Elbowed	2	XZCP1041L2	0.080
				5	XZCP1041L5	0.180
				10	XZCP1041L10	0.360
Female, M12	8	XCSDMP●0●	Straight	2	XZCP29P11L2	0.100
				5	XZCP29P11L5	0.290
				10	XZCP29P11L10	0.470
			Elbowed	2	XZCP1141L2	0.090
				5	XZCP1141L5	0.190
				10	XZCP1141L10	0.370
Female, M12	4	XCSDMP●9●/ XCSDMR●9●	Straight	2	XZCP1141L2	0.090
				5	XZCP1141L5	0.190
				10	XZCP1141L10	0.370
			Elbowed	2	XZCP1241L2	0.090
				5	XZCP1241L5	0.190
				10	XZCP1241L10	0.370

Function diagrams with magnet present

XCSDMC59●●

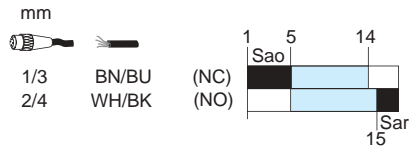

XCSDMC79●●

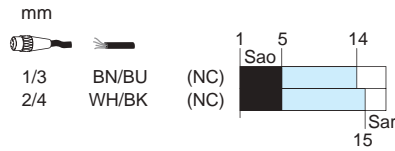

XCSDMP50●●

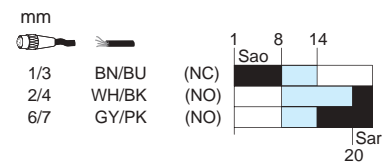

XCSDMP70●●

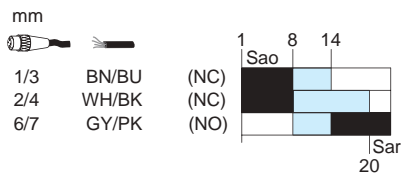

XCSDMR59●●/XCSDMP59●●

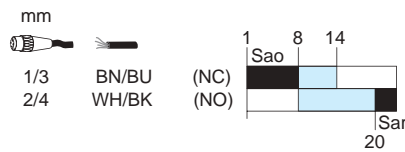

XCSDMR79●●/CS DMP79●●

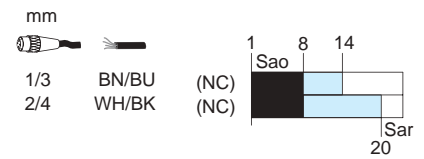

- Contact closed
- Contact open
- Transient state

Sao: assured operating distance.
Sar: assured release distance.
Conforming to EN/IEC 60947-5-3

Safety detection solutions

Coded magnetic safety switches

XCSDMC compact rectangular

XCSDMP standard rectangular, XCSDMR cylindrical

Plastic

Coded magnetic switches

XCSDMC

Pre-cabled connection

Connector on flying lead connection

Coded magnet for XCSDMC

XCSZC1

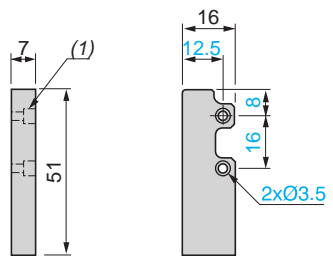
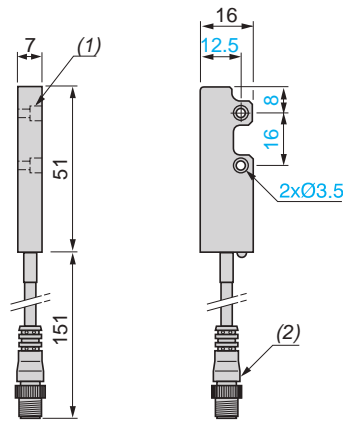
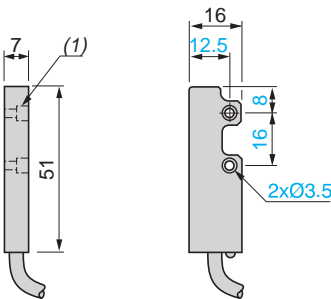

(1) Counterbored: $\varnothing 6 \times 3.5$ mm.

(1) Counterbored: $\varnothing 6 \times 3.5$ mm.
(2) M8 4-pin connector.

(1) Counterbored: $\varnothing 6 \times 3.5$ mm.

XCSDMP

Pre-cabled connection

Connector on flying lead connection

Coded magnet for XCSDMP

XCSZP1

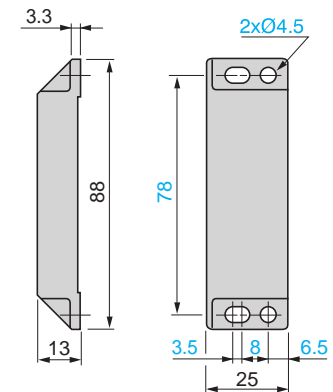
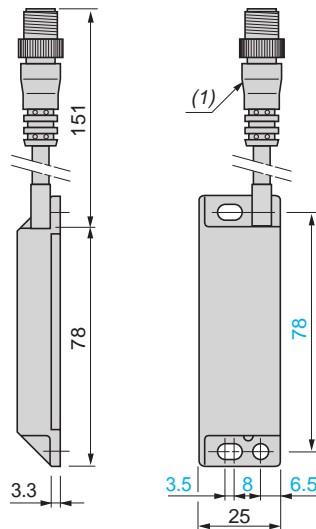
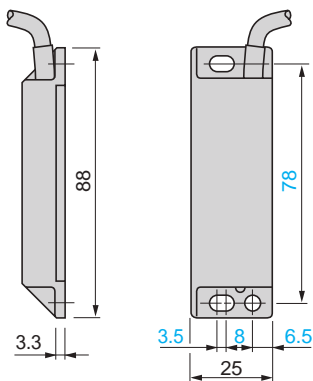

(1) M12 4 or 6-pin connector.

XCSDMR

Pre-cabled connection

Connector on flying lead connection

Coded magnet for XCSDMR

XCSZR1

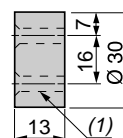
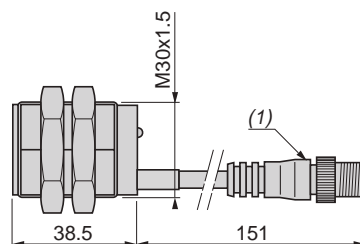
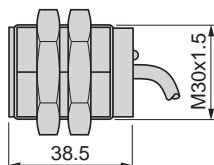

(1) M12 4-pin connector.

(1) $2 \times \varnothing 4.3$, countersunk: $\varnothing 7.5$ at 45° .

Accessories

Fixing clamp

XSZB130

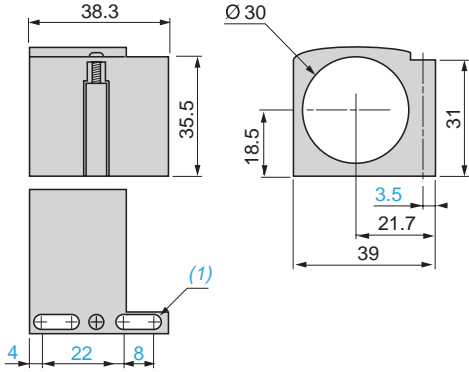

Non-magnetic shims

XCSZCC

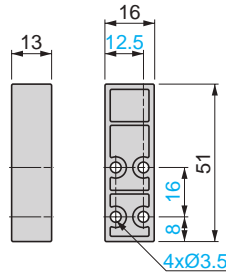

XCSZCP

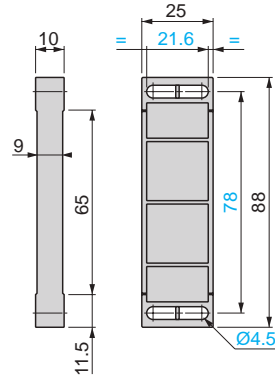

XCSZCR

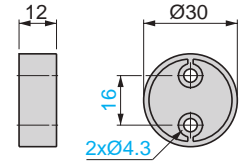

(1) 2 elongated holes Ø 4 x 8

Pre-wired connectors

XZCP0941L●

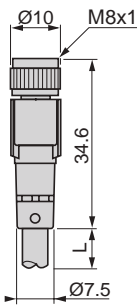

XZCP1041L●

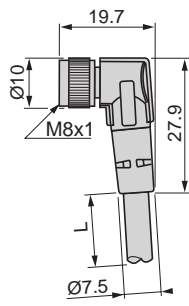

XZCP1141L●

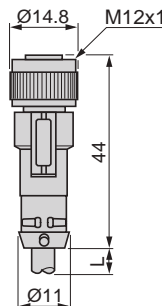

XZCP1241L●

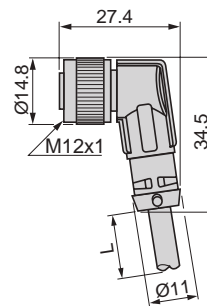

XZCP29P11L●

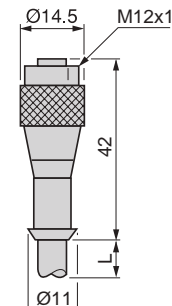

Mounting

XCSDMC

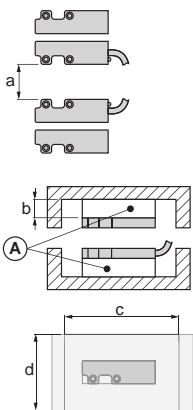

XCSDMP

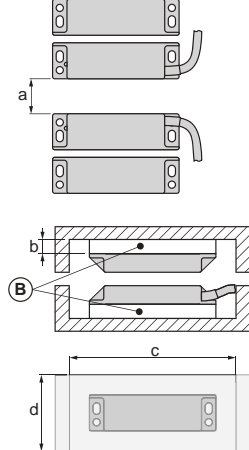

XCSDMR

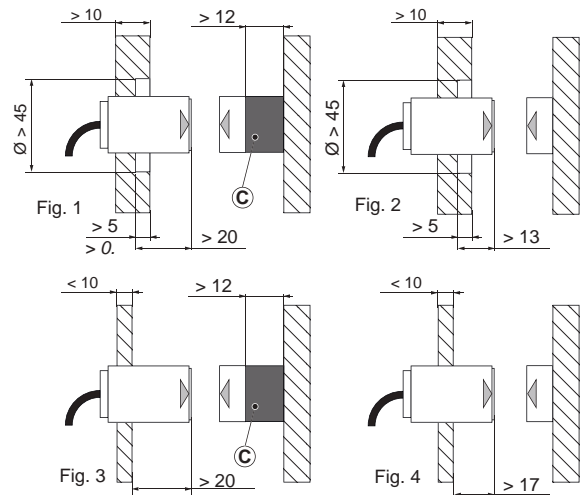

XCS (mm)	a ≥	b ≥	c x d ≥
DMC	40	13	81 x 55
DMP	100	10	118 x 55

Non-magnetic shims

A	XCSZCC (x2)
B	XCSZCP (x2)
C	XCSZCR (x1)

Safety detection solutions

Coded magnetic safety switches

XCSDMC compact rectangular

XCSDMP standard rectangular, XCSDMR cylindrical

Schemes

M8 pre-wired connector

XZCP0941L●

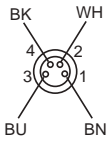

M12 pre-wired connector

XZCP1141L●, XZCP1241L●

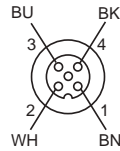

XZCP29P11L●

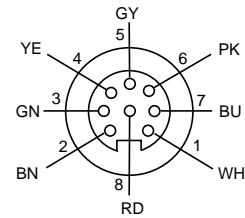

XCSDM●5●●● with XPSUS●

Wiring to PL=e, category 4 conforming to EN/ISO 13849-1 and SIL 3 conforming to EN/IEC 61508. Example with 3-pole 1 NC + 2 NO (1 NO staggered) contact.

Note: these schemes are given as examples only, the designer should refer to the relevant safety standards for guidance.

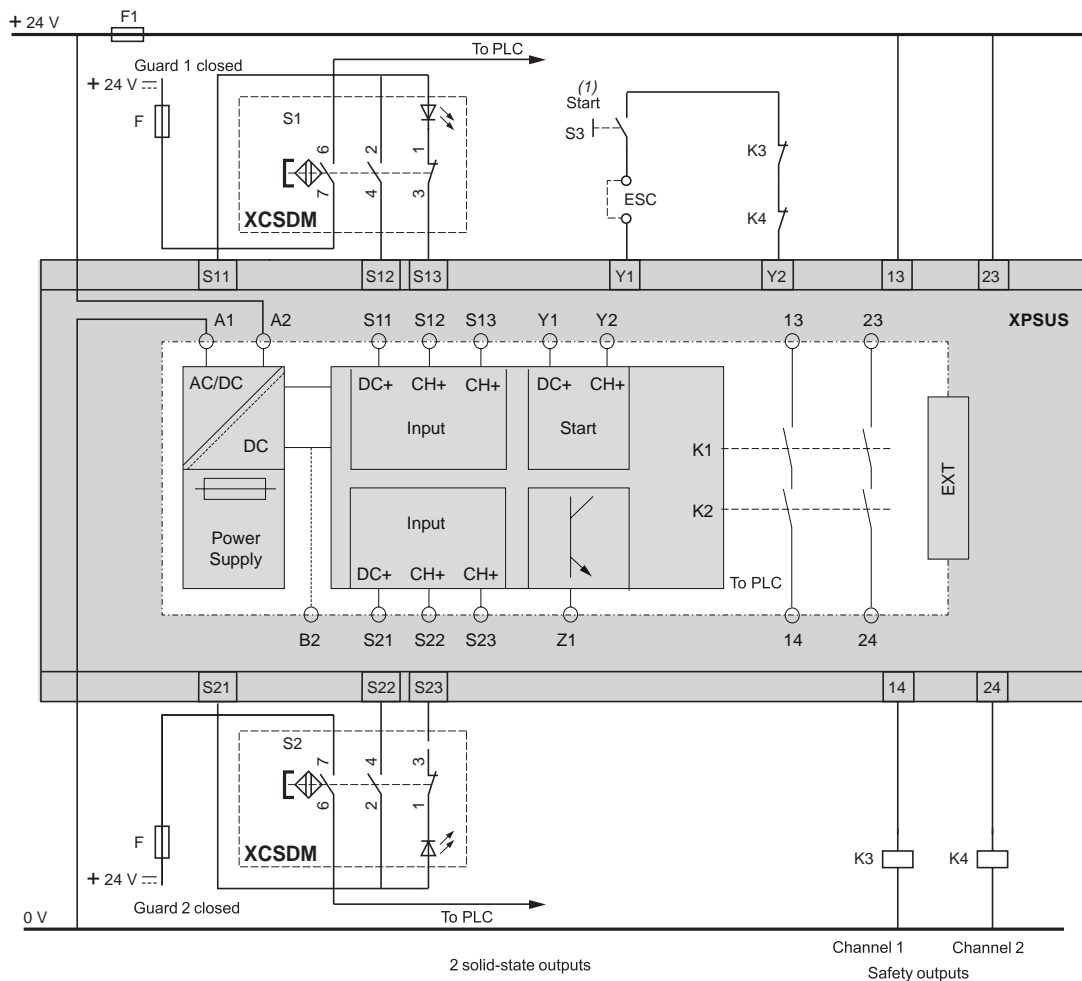

(1) The start function is configured by means of the XPSUAF start function selector.

ESC: External start conditions.

Safety detection solutions

Coded magnetic safety switches

XCSDMC compact rectangular

XCSDMP standard rectangular, XCSDMR cylindrical

XCSDM●59●● with XPSUDN●

Wiring to PL=e, category 4 conforming to EN/ISO 13849-1 and SIL 3 conforming to EN/IEC 61508. Example with 2-pole 1 NC + 1 NO (staggered) contact.

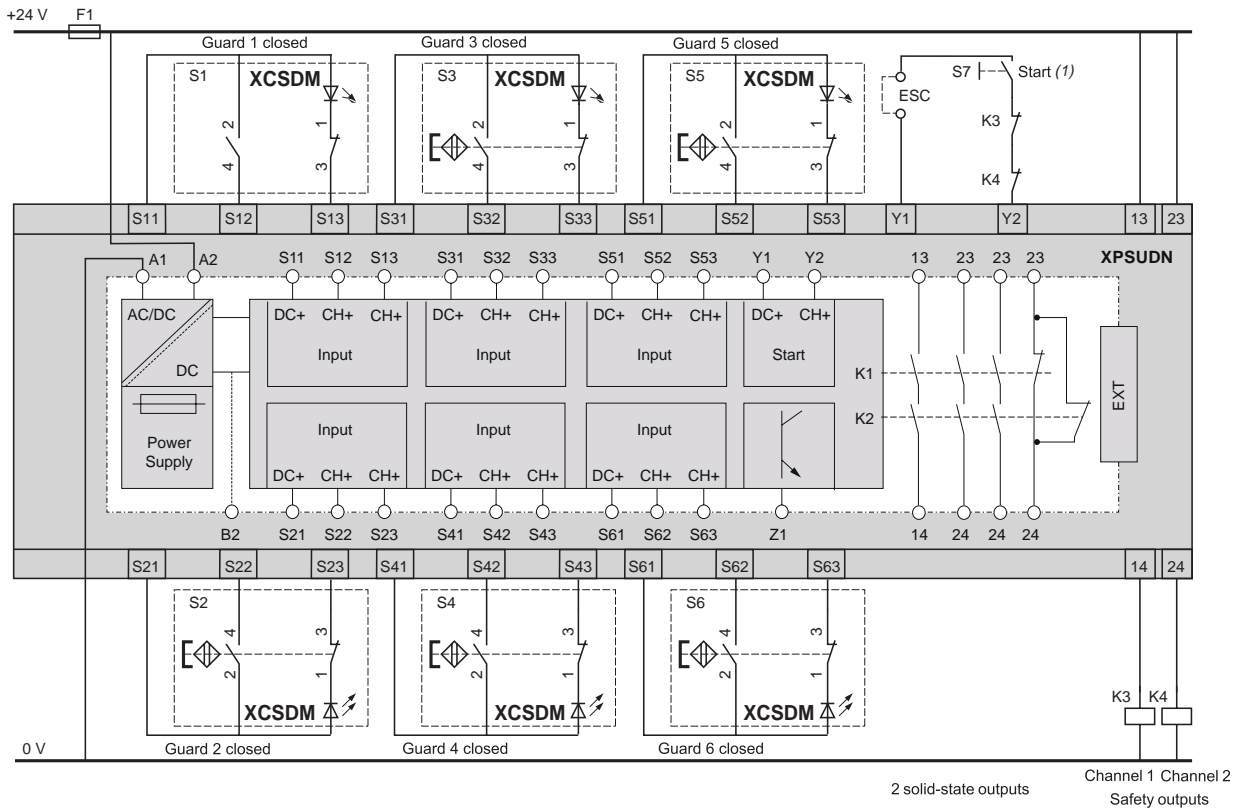

2 solid-state outputs

Channel 1 Channel 2
Safety outputs

(1) The start function is configured by means of the XPSUAF start function selector.

ESC: External start conditions.

XCSDM●79●● with XPSUAF

Wiring up to PL=e, category 4 conforming to EN/ISO 13849-1 and SIL 3 conforming to EN/IEC 61508. Example with 2-pole 2 NC contact

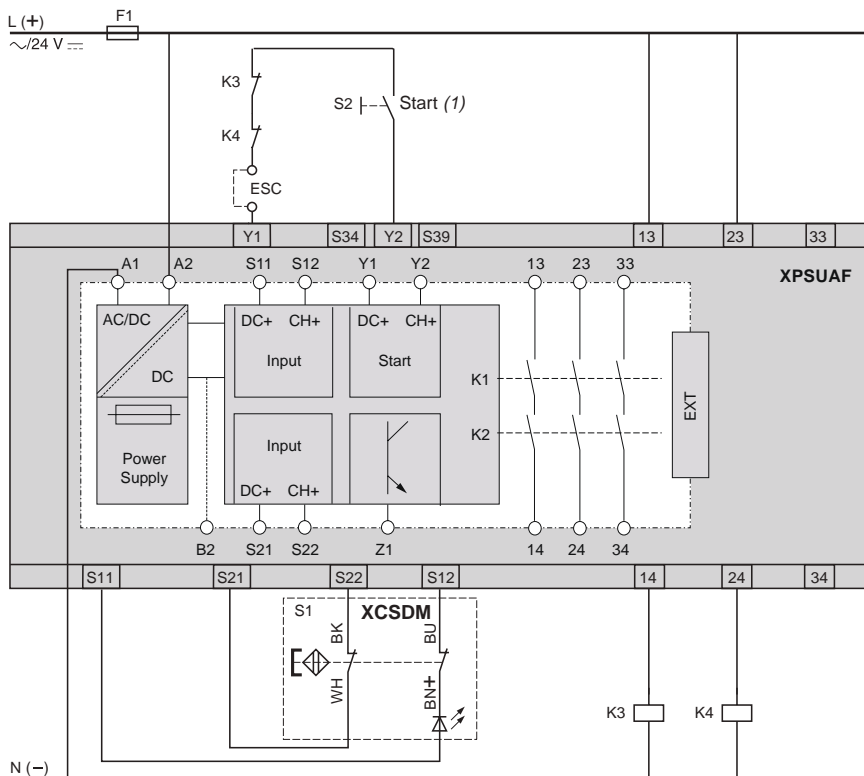

(1) The start function is configured by means of the XPSUAF start function selector.

ESC: External start conditions.

Safety control units

XPSU universal safety relays

Safety functions

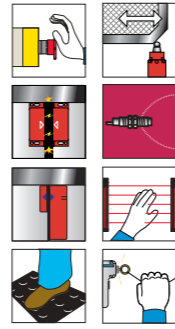
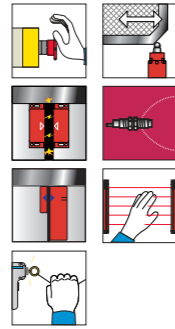

Safety modules for monitoring

- Emergency stop
- Guard switch
- Magnetic switch
- Proximity safety switch
- PNP sensor
- RFID safety switch
- Safety light curtain

- Emergency stop
- Guard switch
- Magnetic switch
- Proximity safety switch
- PNP & NPN sensor
- RFID safety switch
- Safety light curtain
- Sensing mat/edges



Maximum achievable safety level

- PL e/Category 4 conforming to ISO 13849-1
- SILCL 3 conforming to IEC 62061
- SIL 3 conforming to IEC 61508

Conformity to standards

- IEC 60947-5-1
- IEC 61508-1 (functional safety standard)
- IEC 61508-2 (functional safety standard)
- IEC 61508-3 (functional safety standard)
- ISO 13849-1 (functional safety standard)
- IEC 62061 (functional safety standard)

Product certifications

- cULus
- TÜV

Number of outputs

Safety	3 NO	2 NO + 1 NC
Diagnostic	1 solid state	1 redundant NC, 1 solid state

Display

6 LEDs	6 LEDs
--------	--------

Supply voltage

24 V ~/∩ and 48-240 V ~/∩

Synchronization time between inputs

Selectable	Selectable
------------	------------

Input channels

Number	2	2
--------	---	---

Module type

XPSUAF	XPSUAK
---------------	---------------

Complete references and other XPSU universal safety relays are available on www.schneider-electric.com

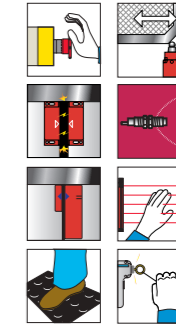
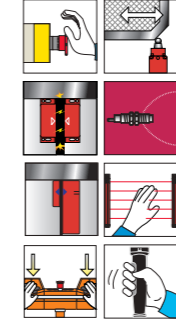
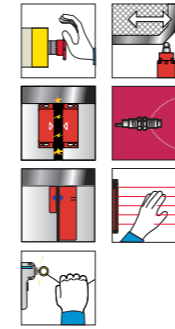

- Emergency stop
- Guard switch
- Magnetic switch
- Proximity safety switch
- PNP sensor
- RFID safety switch
- Safety light curtain

- Emergency stop
- Guard switch
- Magnetic switch
- Proximity safety switch
- PNP sensor
- RFID safety switch
- Safety light curtain
- Two-hand control station
- Enabling switch

- Emergency stop
- Guard switch
- Magnetic switch
- Proximity safety switch
- PNP & NPN sensor
- RFID safety switch
- Safety light curtain
- Sensing mat/edges



- PL e/Category 4 conforming to ISO 13849-1
- SILCL 3 conforming to IEC 62061
- SIL 3 conforming to IEC 61508

- IEC 60947-5-1
- IEC 61508-1 (functional safety standard)
- IEC 61508-2 (functional safety standard)
- IEC 61508-3 (functional safety standard)
- ISO 13849-1 (functional safety standard)
- IEC 62061 (functional safety standard)

- cULus
- TÜV

3 NO + 1 NC	2 NO	3 NO immediate + 3 NO configurable + 1 NC configurable
1 redundant NC, 1 solid state	1 solid state	2 solid state

16 LEDs	8 LEDs	8 LEDs
---------	--------	--------

24 V ~/∩ and 48-240 V ~/∩

Selectable	Selectable	Selectable
------------	------------	------------

12	4	3
----	---	---

XPSUDN	XPSUS	XPSUAT
---------------	--------------	---------------

Complete references and other XPSU universal safety relays are available on www.schneider-electric.com

Safety functions

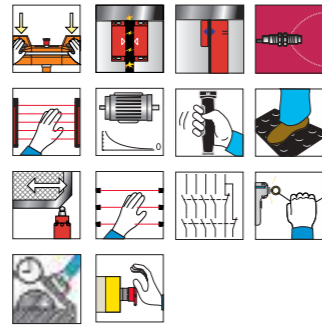

Safety modules for monitoring

- Two-hand control station
- Magnetic switch
- RFID safety switch
- Proximity safety switch
- Safety light curtain
- Safety light grids
- Zero speed detection of AC or DC motors
- Enabling switch
- Sensing mat/edges
- Guard switch
- Number of safety contacts extension
- Emergency stop rope pull switches
- Emergency stop
- Monitoring of applications requiring safety time delays

Maximum safety level achieved by the solution

PL e/Cat 4 SILCL 3 5 (EN/ISO 13849-1, EN/IEC 62061)



Function	Central Unit (CPU) (standalone) (2)	Extension unit input/output		
Case dimensions	22.5 x 99 x 114.5			
Main characteristics	<ul style="list-style-type: none"> 8 digital inputs 2 x 400 mA OSSD pairs 4 test outputs 2 status outputs 2 EDM inputs 	<ul style="list-style-type: none"> 8 digital inputs 2 x 400 mA OSSD pairs 4 test outputs 2 status outputs 2 EDM inputs 	<ul style="list-style-type: none"> 8 or 16 digital inputs 4 test outputs 	<ul style="list-style-type: none"> 2 or 4 x 400 mA OSSD pairs 2 or 4 status outputs 2 or 4 EDM inputs
Reference	XPSMCMCP0802 (1)	XPSMCMMX	XPSMCMCI	XPSMCMDO

(1) Configuration, programming, simulation and documentation by means of intuitive software (SoSafe).

(2) Extension units available (input, output, relay, speed control, communication).

Note: Complete references and other XPSMCM safety controller modules are available on www.schneider-electric.com.

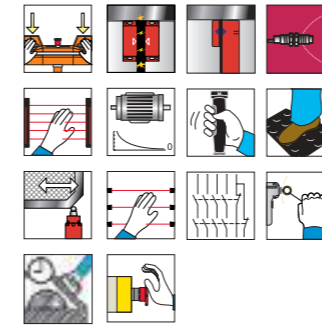

- Two-hand control station
- Magnetic switch
- RFID safety switch
- Proximity safety switch
- Safety light curtain
- Safety light grids
- Zero speed detection of AC or DC motors
- Enabling switch
- Sensing mat/edges
- Guard switch
- Number of safety contacts extension
- Emergency stop rope pull switches
- Emergency stop
- Monitoring of applications requiring safety time delays

Maximum safety level achieved by the solution

Without safety level



Function	Extension unit relay outputs	Extension unit speed control	Extension unit communication	Extension unit bus communication
Case dimensions	22.5 x 99 x 114.5			
Main characteristics	<ul style="list-style-type: none"> 2 or 4 2 NO + 1 NC safety relay outputs (without connection to the extension bus) 1 or 2 EDM inputs 	<ul style="list-style-type: none"> 4 modules with 2 NO + 1 NC safety relay outputs (with connection to the extension bus) 4 independent safety relay outputs and 4 corresponding EDM outputs 0 or 8 status outputs 	<ul style="list-style-type: none"> 1 or 2 inputs for encoder (TTL or HTL or Sin/ Cos) or 1 or 2 inputs for proximity sensors 2 configurable digital outputs 	<ul style="list-style-type: none"> For connecting XPSM-CMCP0802 to remote modules (= 50 m) Creation of 6 islands, with full length of 250 m and maximum 50 m between 2 communication modules
Reference	XPSMCMER	XPSMCMRO	XPSMCMEN	XPSMCMCO0000S XPSMCMCO0000

(1) Configuration, programming, simulation and documentation by means of intuitive software (SoSafe).

Note: Complete references and other XPSMCM safety controller modules are available on www.schneider-electric.com.

D					
DE9RA1012	79	XCSDMP500L01M12	99	XCSZ02	48
DE9RA1016	79	XCSDMP501L01M12	99		62
DE9RA2012	71	XCSDMP590L01M12	99		71
DE9RP13520	71	XCSDMP591L01M12	99	XCSZ03	48
		XCSDMP700L01M12	99		62
		XCSDMP701L01M12	99		71
X		XCSDMP790L01M12	99	XCSZ05	48
XCSLE2727313	60	XCSDMP791L01M12	99		62
XCSLE2727312	60	XCSDMP5002	98		71
XCSLE2525312	60	XCSDMP5902	98	XCSZ11	45
XCSLE2525332	60	XCSDMP5912	98		79
XCSLE2525342	60	XCSDMP7002	98	XCSZ12	45
XCSLE2525512	60	XCSDMP7012	98		79
XCSTE5512	78	XCSDMP7902	98	XCSZ13	45
XCSTE5312	78	XCSDMR590L01M12	99		79
XCSTE5311	78	XCSDMR591L01M12	99	XCSZ14	45
XCSTE5313	78	XCSDMR790L01M12	99		79
XCSA502	48	XCSDMR791L01M12	99	XCSZ15	45
XCSA512	48	XCSDMR5902	98		79
XCSA522	48	XCSDMR5912	98	XCSZ21	45
XCSA702	48	XCSDMR7902	98		49
XCSA712	48	XCSDMR7912	98	XCSZ25	49
XCSA722	48	XCSE5312	70		62
XCSA802	48	XCSE5322	70		71
XCSB502	48	XCSE5332	70	XCSZ27	49
XCSB702	48	XCSE5342	70		71
XCSB802	48	XCSE7312	70	XCSZ28	44
XCSC502	48	XCSE7332	70		79
XCSC702	48	XCSE7342	70	XCSZ29	49
XCSC802	48	XCSE8312	70		62
XCSD3702G13	31	XCSE73127	70	XCSZ30	62
XCSD3702N12	31	XCSE83127	70		49
XCSD3702P20	31	XCSLE353531M3	61	XCSZ31	49
XCSD3710G13	31	XCSLE373731M3	61		49
XCSD3710N12	31	XCSLE3535312	60	XCSZ32	49
XCSD3710P20	31	XCSLE3737312	60		89
XCSD3718G13	31	XCSLE3838312	60	XCSZ71	89
XCSD3718N12	31	XCSLF353531M3	57		40
XCSD3718P20	31	XCSLF353541M3	59	XCSZ81	40
XCSD3719G13	31	XCSLF373731M3	57		40
XCSD3719N12	31	XCSLF373741M3	59	XCSZ83	40
XCSD3719P20	31	XCSLF383831M3	57		40
XCSD3902G13	30	XCSLF2525312	56	XCSZ84	40
XCSD3902N12	30	XCSLF2725312	56	XCSZ85	40
XCSD3902P20	30	XCSLF2727312	56	XCSZ90	49
XCSD3910G13	30	XCSLF3535312	56		62
XCSD3910N12	30	XCSLF3535412	58		71
XCSD3910P20	30	XCSLF3737312	56	XCSZ91	44
XCSD3918G13	30	XCSLF3737412	58		79
XCSD3918N12	30	XCSLF3838312	56	XCSZ100	62
XCSD3918P20	30	XCSM3702L1	26		79
XCSD3919G13	30	XCSM3710L1	26	XCSZ200	44
XCSD3919N12	30	XCSM3715L1	26		79
XCSD3919P20	30	XCSM3716L1	26	XCSZ210	62
XCSDMC59010	98	XCSM3902L1	26		62
XCSDMC590L01M8	99	XCSM3910L1	26	XCSZ211	62
XCSDMC591L01M8	99	XCSM3915L1	26	XCSZC1	100
XCSDMC790L01M8	99	XCSM3916L1	26	XCSZCC	100
XCSDMC791L01M8	99	XCSM4102L1	26	XCSZCP	100
XCSDMC5902	98	XCSM4110L1	26	XCSZCR	100
XCSDMC5912	98	XCSM4115L1	26	XCSZP1	98
XCSDMC7902	98	XCSM4116L1	26		100
XCSDMC7912	98	XCSP3902G13	32	XCSZP5012	98
XCSDMC5012	98			XCSZR1	100
				XSZB130	100
				XZCC23FCM190S	63
				XZCC23FDM190S	63
				XZCP11V12L2	90
				XZCP11V12L5	90
				XZCP11V12L10	90
				XZCP11V12L20	90
				XZCP12V12L2	90
				XZCP12V12L5	90
				XZCP12V12L10	90
				XZCP12V12L20	90
				XZCP29P11L2	100
				XZCP29P11L5	100
				XZCP29P11L10	100
				XZCP29P12L2	90
				XZCP29P12L5	90
				XZCP29P12L10	90
				XZCP29P12L20	90
				XZCP53P12L2	90
				XZCP53P12L5	90
				XZCP53P12L10	90
				XZCP53P12L20	90
				XZCP0941L2	100
				XZCP0941L5	100
				XZCP0941L10	100
				XZCP1041L2	100
				XZCP1041L5	100
				XZCP1041L10	100
				XZCP1141L2	100
				XZCP1141L5	100
				XZCP1141L10	100
				XZCP1241L2	100
				XZCP1241L5	100
				XZCP1241L10	100
				XZCR1111064D03	90
				XZCR1111064D3	90
				XZCR1111064D5	90
				XZCR1111064D10	90
				XZCR1111064D25	90

Schneider Electric Industries SAS

Head Office
35, rue Joseph Monier
F-92500 Rueil-Malmaison
France

www.tesensors.com

The information provided in this documentation contains general descriptions and/or technical characteristics of the performance of the products contained herein. This documentation is not intended as a substitute for and is not to be used for determining suitability or reliability of these products for specific user applications. It is the duty of any such user or integrator to perform the appropriate and complete risk analysis, evaluation and testing of the products with respect to the relevant specific application or use thereof. Neither Schneider Electric nor any of its affiliates or subsidiaries shall be responsible or liable for misuse of the information contained herein.

Design: Schneider Electric
Photos: Schneider Electric

February 2020 - V1.0

DIA4ED2191001EN