

TS 5 transfer system – modular, reliable, efficient

The next generation: the roller conveyor system for heavy loads



The new leader in roller conveyors

The TS 5 transfer system – an optimized, economical solution for every application





The new modular transfer system is now even more flexible and economical.

The new TS 5 transfer system has its sights set squarely on the future. Equipped with modern components and even more practical features, it can be easily integrated into the newly digital world of production – including yours.

Enhanced with numerous modules that offer a high degree of customizing possibilities and a thoughtful modular design principle, the innovative transfer system offers you more freedom than ever in system design and construction.

The heavyweight in the Rexroth program excels thanks to its enormous efficiency and unmatched quality – ensured, among other things, by minimum-maintenance king shaft drive. Even with loads of more than 400 kg, TS 5 stands out as a robust cycle keeper, even in the harshest manufacturing environments – and offers you the greatest possible freedom when it comes to layout planning and use of space. The latest generation of drives, lift-transfer units, conveyor sections, positioning units and stop gates give you even greater agility in deploying and using the system. The easy-to-use, intuitive *MTpro* planning tool helps you with the layout for your own unique system.

A more flexible or economical way to roll out your application simply does not exist.

Distinctive product features and advantages

- ▶ **Modularity:** modular system with a wide application range
- ▶ **Reliability:** drive concept with minimal maintenance and long service life
- ▶ **Efficiency:** easy and fast project planning, components offering highest quality and energy efficiency



1. Simple design

Thanks to the clever combination of the customer-friendly *MTpro* CAD program and the intelligent design of the components, the system can be customized according to your wishes.

2. Modular construction

TS 5's modular design principle makes a variety of layouts possible. As a result, changing or expanding the transfer system couldn't be easier.

3. Reliable system

The TS 5 is an extremely reliable system with the highest degree of quality. The drive offers a long service life requiring minimum maintenance.

4. Efficient concept

When it comes to intelligent solutions, the efficient concept of the TS 5 is simply unbeatable. Whether your focus is total cost of ownership or better energy efficiency, TS 5 is head and shoulders above the rest.

5. System solutions that meet your needs

With a system width ranging from 455 to 1040 mm and the ability to freely choose the length of the roller section, it's easy to select and implement the exact you need.

6. Future oriented

Links to Industry 4.0 enabled solutions, such as the ActiveCockpit interactive communication platform and the ActiveAssist guided workstation, are no problem whatsoever.

New, thoughtfully-designed modules add more flexibility to individual system design

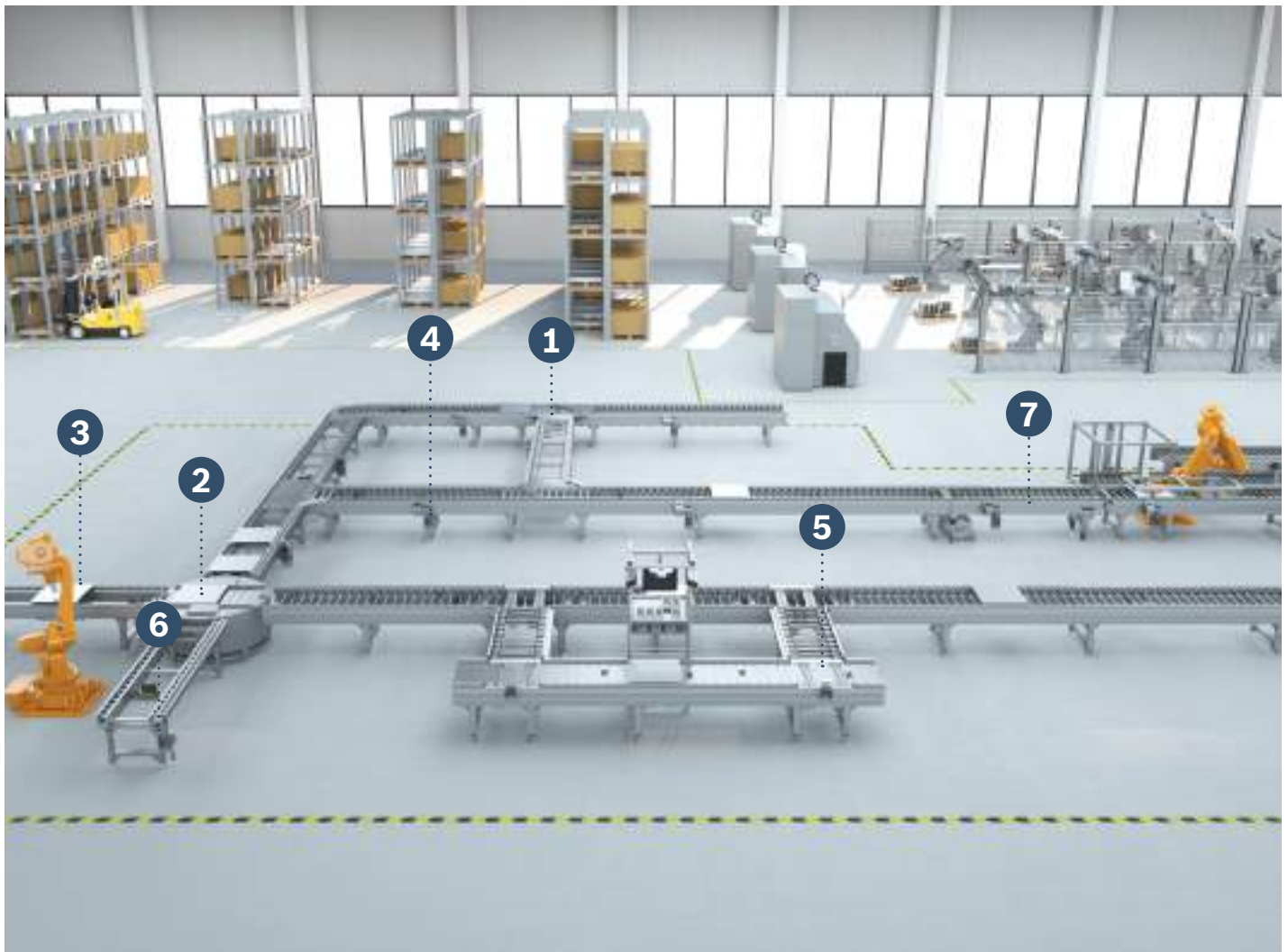

1. 3WW three-way diverter

T-shaped outfeed with three options: right, left, up or down.

- ▶ Ability to branch off or merge in two directions and also reversible, for all system sizes
- ▶ Economical solution for two parallel sections with curves

2. RU 5 rotation unit

Performs the function of a diverter, junction and crossing in one unit.

- ▶ Alternative for curves with higher weight classes up to 600 kg
- ▶ For all system sizes
- ▶ Rotation: $\pm 90^\circ$ and 180° (45° and 135° possible)

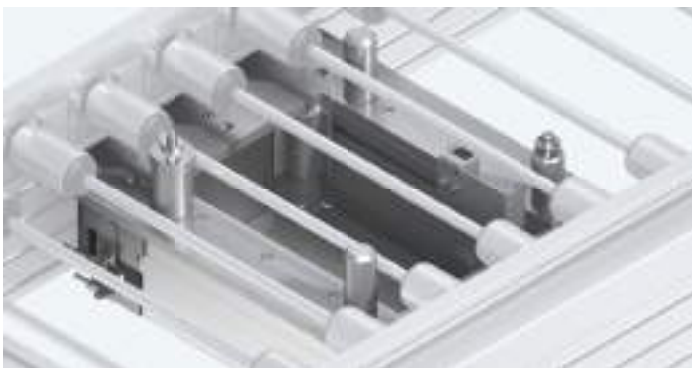

3. PE 5 positioning unit

Absolute precision through accurate positioning of workpieces at processing stations.

- ▶ Accuracy ± 0.3 mm, stroke 5.0 mm
- ▶ Positioning in both longitudinal and transverse conveyor sections
- ▶ Can be mounted at any point along the conveyor, depending on roller placement
- ▶ Optional safety housing can be removed from the side
- ▶ Now also available as open-center version

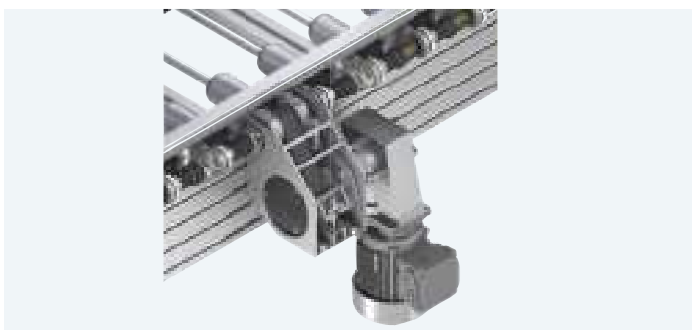

4. AS 5 drive unit

Powerful drive unit incl. conveyor section with flexible configuration options.

- ▶ Individual layout options: flexibility regarding the motor positioning thanks to the variable length
- ▶ Drive power up to 45 Nm, reversing (20 Nm)
- ▶ Speeds: 2, 4, 6, 9, 12, 15, 18 m/min, storage capable

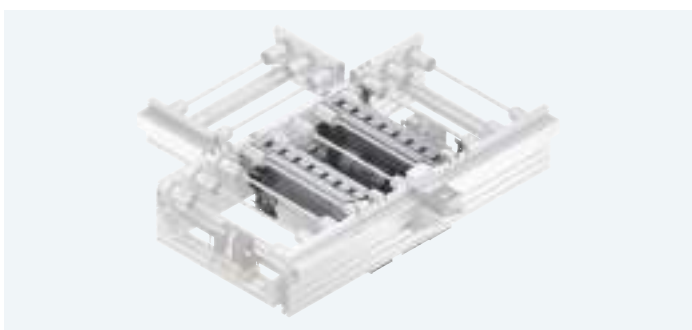

5. HQ 5 lift transverse unit

Easy to transport workpieces in the transverse section. Separate, self-contained unit incl. conveyor section with simple, robust design.

- ▶ Available as HQ 5/H and HQ 5/XH
- ▶ Stroke 4.5 mm
- ▶ Optional safety housing can be removed from the side
- ▶ Speeds: 6, 9, 12 m/min



6. AB 5 drive kit

Drive kit as separate, self-contained module with conveyor section which can be placed at the beginning or end face of the conveyor.

- ▶ Drive power up to 45 Nm, reversing (20 Nm)
- ▶ Speeds: 2, 4, 6, 9, 12, 15, 18 m/min, with accumulation
- ▶ Assembly in curves, diverters, junctions and lift transverse units on request



7. SG 5 swing gate

Mobile swing gate for flexible access.

- ▶ For all standard system sizes, available in the versions SG 5/H, SG 5/XH, SG 5/OC
- ▶ Gate opens up to 180° (depending on the position of the drive)
- ▶ Incl. drive unit and security locking mechanism and safety switch

Simple planning and connection to the world of digital production

Quick and easy project planning – intuitive design with high degree of planning confidence

Easy, economical and quick: These TS 5 attributes are consistent all the way through, from the initial requirements and concept, to the planning phase, to the actual operation of your installed system.

Especially when it comes to project planning, the *MTpro* is a proven, excellent tool which enables planning that is both application-oriented and fast. This significantly shortens the planning process and ultimately saves time and money in the procurement process. Automated order lists and links to the product catalog and installation instructions further simplify the entire project planning process.



Modern production and the world of Industry 4.0 – digital integration plays a major role with TS 5

Innovative concepts, and most importantly a forward-looking orientation in production planning, play an important role at Bosch Rexroth – and that includes TS 5. The components are equipped with the latest technology and make it possible to control the speed centrally using variable frequency drives. Integration with the interactive communication platform ActiveCockpit allows access to production data in real time. Parameters such as energy efficiency, cycle time and workpiece pallet tracking can be measured and visualized for increased transparency and more efficient production processes.



Bosch Rexroth AG

PO Box 30 20 07
70442 Stuttgart, Germany
www.boschrexroth.com

You can find local contact information at:

www.boschrexroth.com/contact

The data specified above only serves to describe the product.

Due to the continuous development of our products, no statements concerning a specific characteristic or suitability for a specific application can be inferred from the information that we provide. The information given does not release the user from the obligation of own judgment and verification.

It must be remembered that our products are subject to a natural process of wear and aging.